



Ultra-Bond



Composite Floor Deck

DESIGN TABLE DETAILS.....	- 1 -
INTRODUCTION.....	- 2 -
COMPOSITE ACTION.....	- 2 -
DESIGN RESPONSIBILITY.....	- 2 -
DESIGN CRITERIA AND TECHNICAL DATA.....	- 3 -
STEEL DECK MATERIAL.....	- 3 -
LIMIT STATE DESIGN (LSD).....	- 3 -
STEEL DECK SECTION PROPERTIES.....	- 4 -
DESCRIPTION OF LOAD TABLES.....	- 4 -
CONSTRUCTION LOADS.....	- 13 -
COMPOSITE LOADING.....	- 13 -
COMPUTER PROGRAM.....	- 14 -
EXAMPLES FOR THE PROPER USE OF STEELFORM ULTRA-BOND LOAD TABLES.....	- 14 -
LINK.....	- 21 -
CONSTRUCTION GUIDELINES.....	- 21 -
DECKING INSTALLATION.....	- 21 -
<i>Restraint Straps.....</i>	- 21 -
<i>Penetrations.....</i>	- 21 -
<i>Temporary Supports.....</i>	- 22 -
<i>Hanger System.....</i>	- 22 -
<i>End Closures.....</i>	- 22 -
<i>Side-lap Washers.....</i>	- 23 -
<i>Cantilevers.....</i>	- 23 -
<i>Perimeter Edge Trims.....</i>	- 23 -
<i>Columns and Ultra-Bond Floor Decking.....</i>	- 23 -
<i>Rib Reinforcement and Mesh Placement.....</i>	- 23 -
<i>Concrete Placement.....</i>	- 23 -
<i>Service Holes.....</i>	- 23 -
<i>Ceiling Hanger System.....</i>	- 24 -
TRIMS AND ACCESSORIES.....	- 24 -

Design Table Details

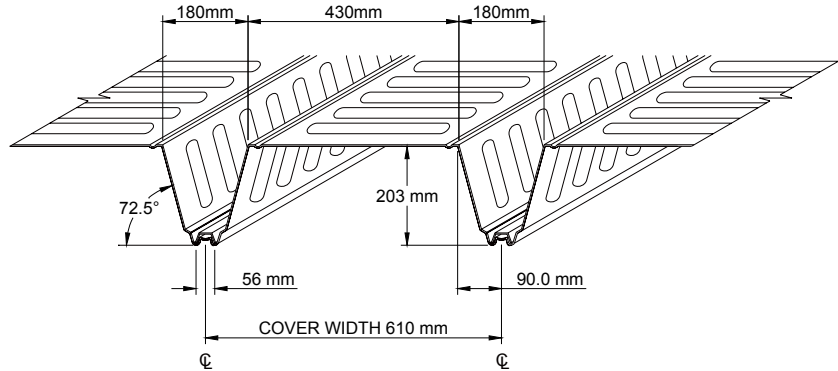

	ULTRABOND STEEL DECK FULL SECTION PROPERTIES (Imperial Units)					
---	--	--	--	--	--	--

NOMINAL THICKNESS (IN)	CORE THICKNESS (IN) ¹	PROFILE DEPTH (IN)	PROFILE WEIGHT (PSF)	A _F (IN ²)/ft	I _{x(F)} (IN ⁴)/ft	S _{x(F)} (IN ³)/ft
0.0394	0.0378	8.0" (out to out)	2.34	0.687	5.70	1.02
0.0492	0.0476	8.0" (out to out)	2.94	0.865	7.18	1.287

NOTES 1 Design Thickness

	ULTRABOND STEEL DECK EFFECTIVE SECTION PROPERTIES (Si-Metric Units)					
---	--	--	--	--	--	--

NOMINAL THICKNESS (mm)	CORE THICKNESS (mm) ¹	PROFILE DEPTH (mm)	PROFILE WEIGHT (kPa)	A _e (mm ² /m)	I _{e(x)} (10 ⁶ mm ⁴ /m)	S _{e(x)} (10 ³ mm ³ /m)
1.00	0.96	203.2	0.112	617	4.60	36.70
1.25	1.21	203.2	0.141	861	6.93	61.36

NOTES 1 Design Thickness

	ULTRABOND STEEL DECK EFFECTIVE SECTION PROPERTIES (Imperial Units)					
---	---	--	--	--	--	--

NOMINAL THICKNESS (IN)	CORE THICKNESS (IN) ¹	PROFILE DEPTH (IN)	PROFILE WEIGHT (PSF)	A _e (IN ²)/ft	I _{e(x)} (IN ⁴)/ft	S _{e(x)} (IN ³)/ft
0.0394	0.0378	8.00	2.34	0.291	3.37	0.684
0.0492	0.0476	8.00	2.94	0.406	5.09	1.15

NOTES 1 Design Thickness

INTRODUCTION

This Manual and the Load Tables present data to structural engineers, and design professionals on the design of the Steelform Ultra-Bond Composite Floor Deck System, incorporating steel reinforcing tension bars. This System uses specially formed steel deck profiles consisting of extensive lugs embossed in the metal deck to allow for positive shear bond between steel and concrete. The aim of this System is to provide:

- a low cost method to obtain a working surface for various trades
- formwork for the concrete floor slab
- positive bending reinforcement for the cured concrete.

Ultra-Bond Composite Floor Deck System can be used in conjunction with composite beam design and provides many varying fire-rating assemblies listed by UL and ULC. **The metal deck can often be modified by addition of flat plates to the underside, to form electrical wire conduits or cold/warm air ducts.**

Composite Action

Composite action (steel and concrete) is developed when two load-carrying structural members, such as concrete and steel, are integrally connected and deflect as a single unit under any load.

The basic advantages resulting from composite design are:

- Reduction in weight of steel (approx. 30%),
- Shallower structural supports,
- Increase in floor stiffness, improved deflection performance,
- Increase in overload capacity (safety due to overload).

Design Responsibility

This Manual and Load Tables are prepared as a guide for structural engineers and design professionals. Every precaution has been taken to ensure that all information presented is factual and that numerical values are accurate. Steelform Building Products Inc. assumes no responsibility for any design liability or errors resulting from the use of this information and Load Tables.

DESIGN CRITERIA AND TECHNICAL DATA

Steel Deck Material

The steel deck used is a continuously hot-dipped zinc coated structural quality sheet, delivered for fabrication in coils. It conforms to ASTM A653M, Grade 280 with a yield strength of 280 MPa (40.6 ksi).

The sheet is available in several coatings for corrosion protection. These coatings would meet the applicable requirements of ASTM A924M. In most applications, the deck is in an interior environment where the atmosphere is mild with regard to corrosion. A ZF75 finish is suitable for this. If the likelihood of corrosion is significantly higher, a heavier galvanizing finish such as Z275 may be appropriate.

- Reinforcing Steel Bars are provided in various diameters, as shown in Load Tables, from 10 mm dia. to 30 mm dia. and meet the requirements of CAN/CSA G30.18 – M1992, with minimum yield strength of 400 MPa (58 ksi). The clear distance of each bar from the base of the metal deck is 39 mm (1.54 in.).
- Concrete is assumed to have a minimum strength of 30 MPa (4.35 ksi) after 28 days curing with maximum size aggregate of 20 mm (0.79 in.) and normal density of 2400 kg/m³ (150 pcf).

Limit State Design (LSD)

Limit State Design principles were used in the development of the Load Tables in accordance with the National Building Code of Canada 1995. Since the self-weight of the steel deck and the concrete have been already included in the structural Load Tables, the Maximum Specified Load shall be:

$$L_s = LL + (0.833) (DL)$$

L_s = Maximum Specified Load

LL = Specified Live Load

DL = Specified Superimposed Dead Load

$$0.8333 = 1.25/1.50$$

1.25 = Dead Load Factor

1.50 = Live Load Factor

For deflection control (serviceability) the Maximum Specified Load is:

$$L_s = LL + (0.833) (DL)$$

L_s = Maximum Specified Load

LL = Specified Live Load

DL = Specified Superimposed Dead Load.

Steel Deck Section Properties

Steel Deck Section Properties have been evaluated based on AISI/COS/NASPEC 2001, approved in Canada by CSA 136-01, and approved in Mexico by CANACERO.

Load Tables

Both, strength and deflection criteria were considered.

- **Strength – only flexure criteria was considered in the calculations, as shear bond (based on testing) is not a mode of failure. Shear bond is defined as the bond between concrete and metal deck, it can be chemical or mechanical (with lugs).**
- Deflection calculations are based on deflection limit of L/360; however, changing the (k) Factor in the Input Section of the Load Tables can accommodate other criteria, such as L/480, L/600 or L/720.

Modular Ratio (n):

$$n = E_s / E_c$$

E_s = Steel Modulus of Elasticity

E_c = Concrete Modulus of Elasticity

Description of Load Tables

The Load Tables contain three Tables and one Multi Graph Chart at the bottom of the page:

- The first Table's **Input Section** contains all the required input information to generate the output data.
- The second Table's **Output Section #1** shows the allowable unshored spans, total dead load and concrete volume.
- (h_f) or (h_c) indicate the maximum height of the concrete cover above top of the metal deck.
- The third Table's **Output Section #2 - Plot Data and Input Section As Shown #**, indicates allowable single unsupported span based on concrete cover above metal deck (h_f) or (h_c) and maximum specified uniformly distributed load.
- The bottom Graphs allow the designer to determine Allowable Unsupported Single Span or Maximum Specified Uniformly Distributed Load for conditions outside those shown in Output Section # 2, for various concrete covers above metal deck top (h_f) or (h_c).

Ultrabond Workbook, Sheets 1 to 10, are in Imperial Units while Ultrabond Workbook, Sheets 11 to 20, are in Metric Units.

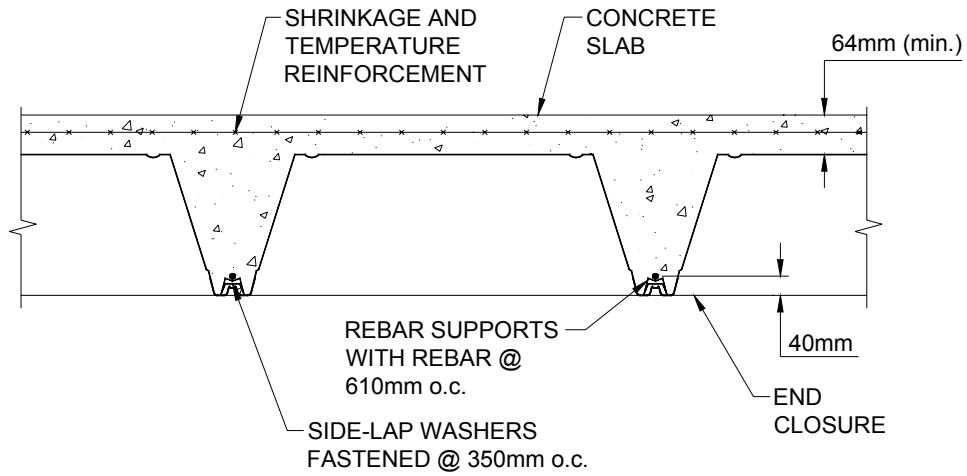

END CLOSURE DETAIL

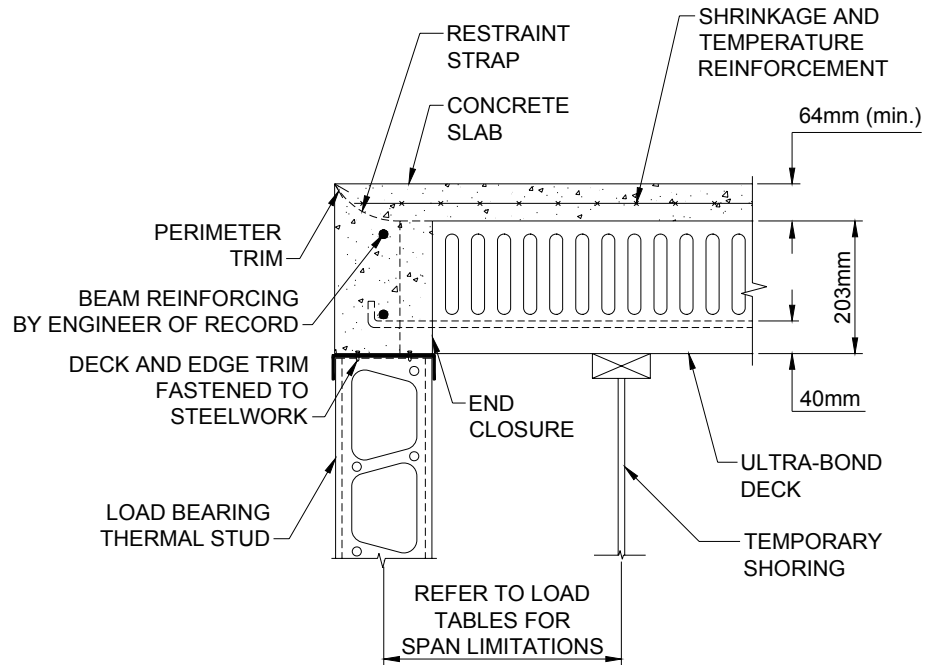

SHORING DETAIL

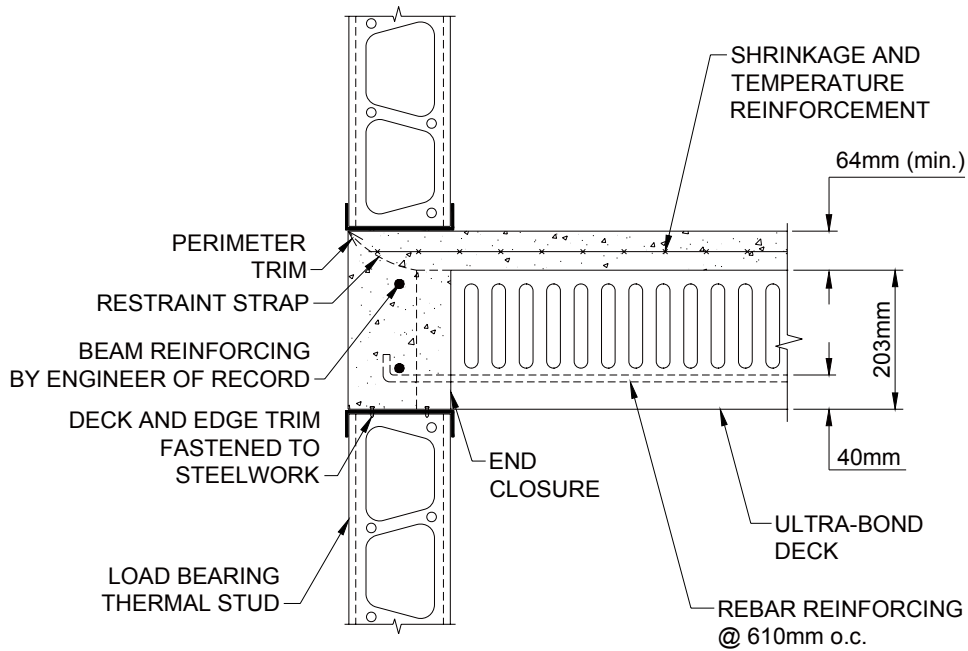

END BEARING DETAIL

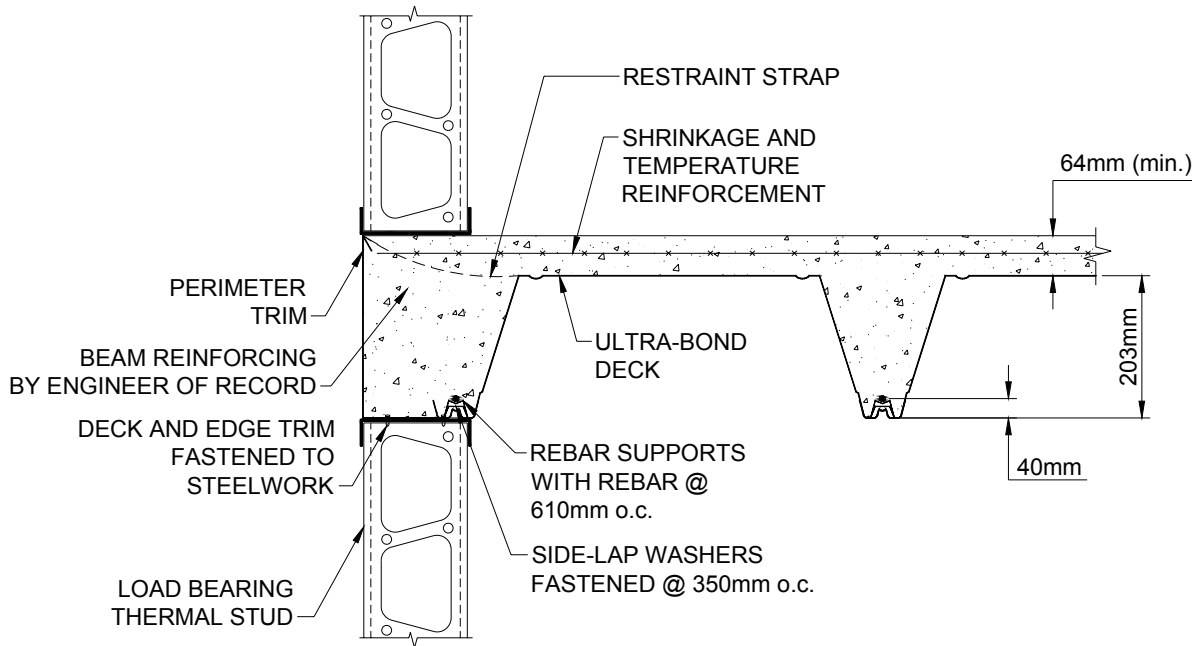

PERIMETER BEARING DETAIL

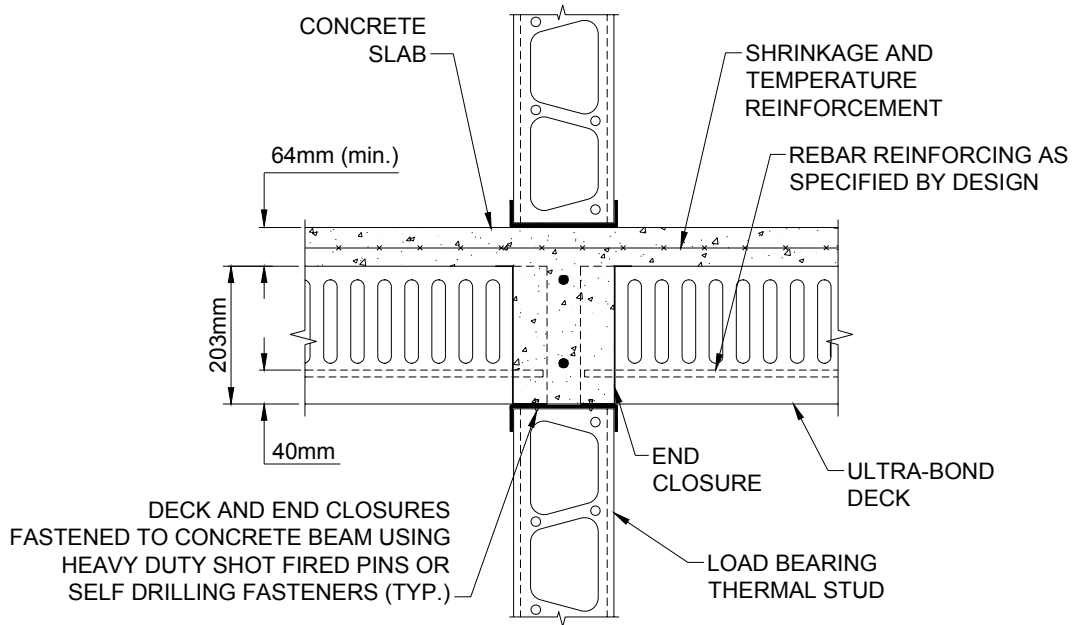

WALL CONNECTION DETAIL

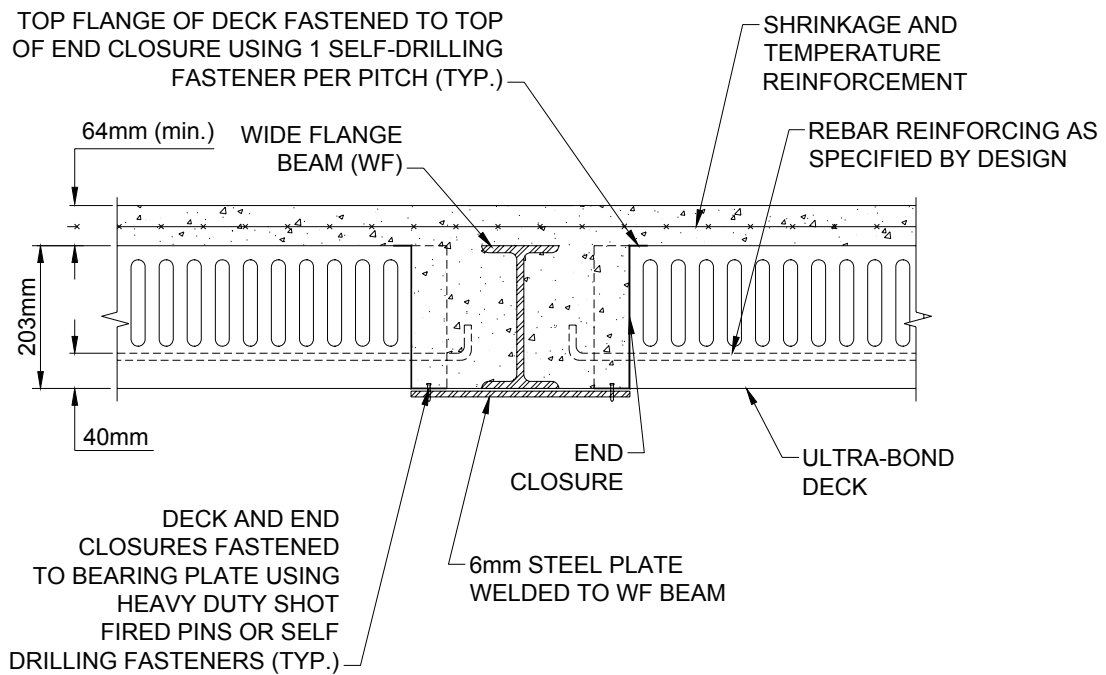

WIDE FLANGE BEAM DETAIL

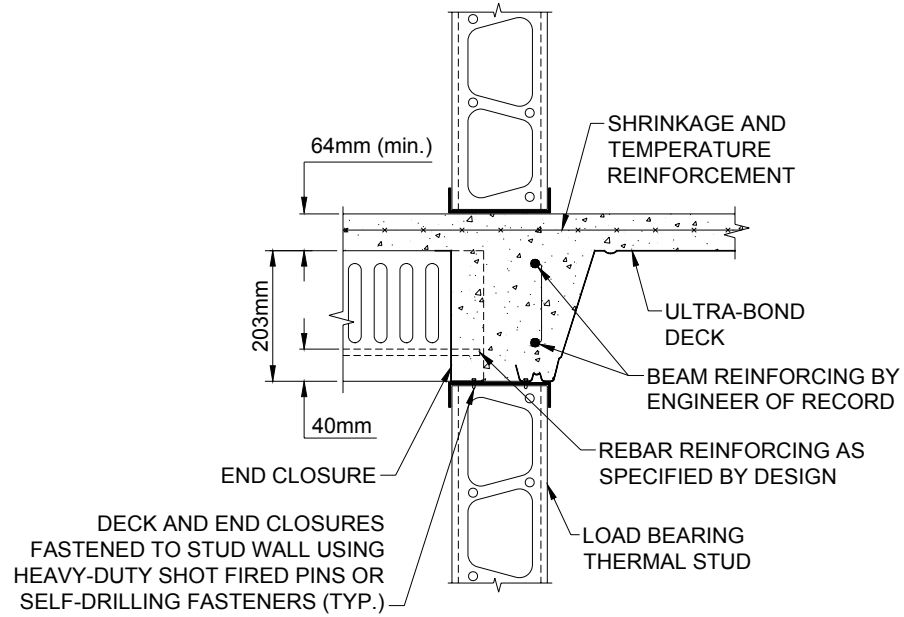

PANEL DIRECTION CHANGE DETAIL

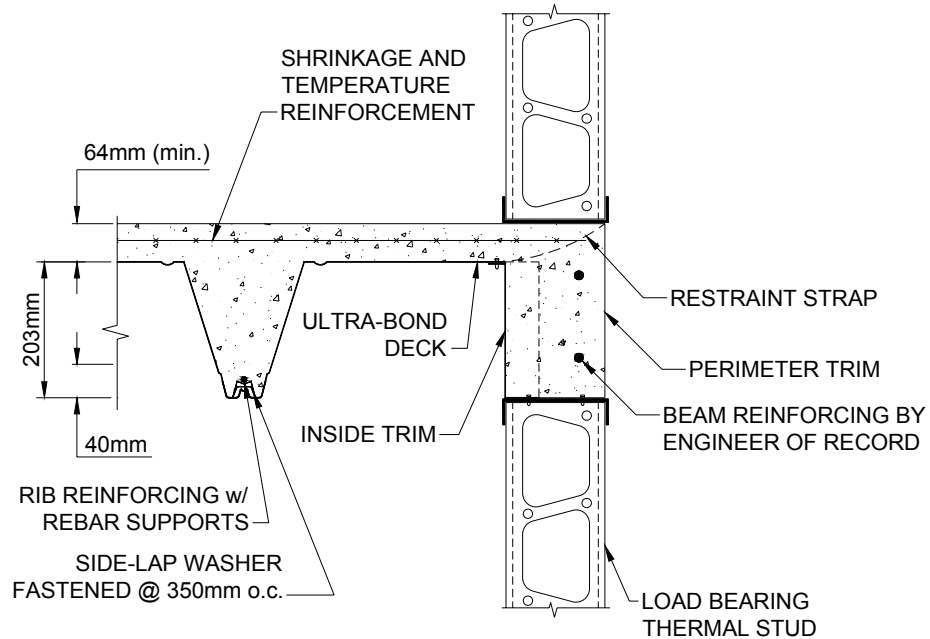

SIDE PERIMETER BEARING DETAIL

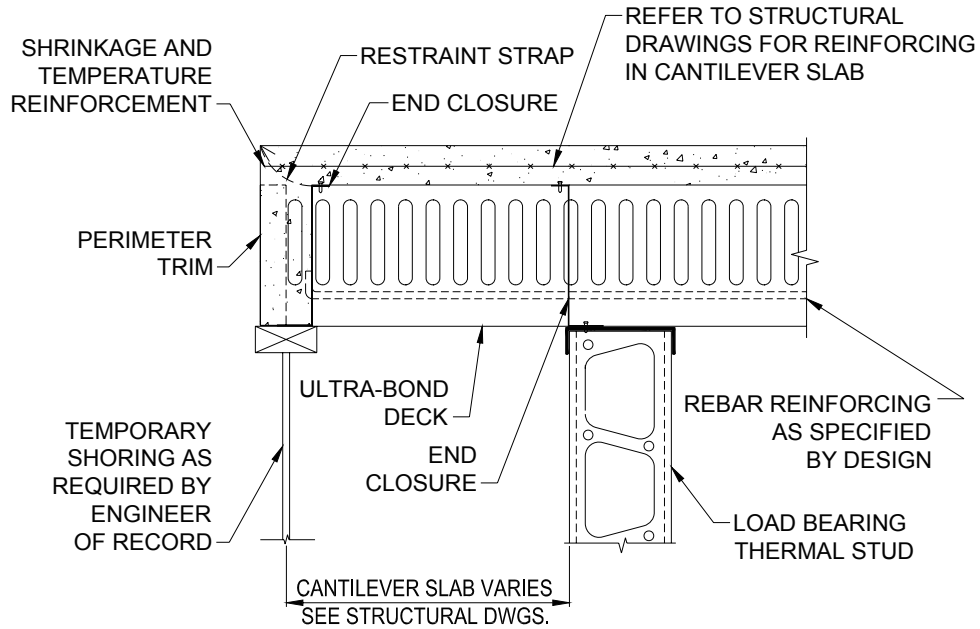

END CANTILEVER DETAIL

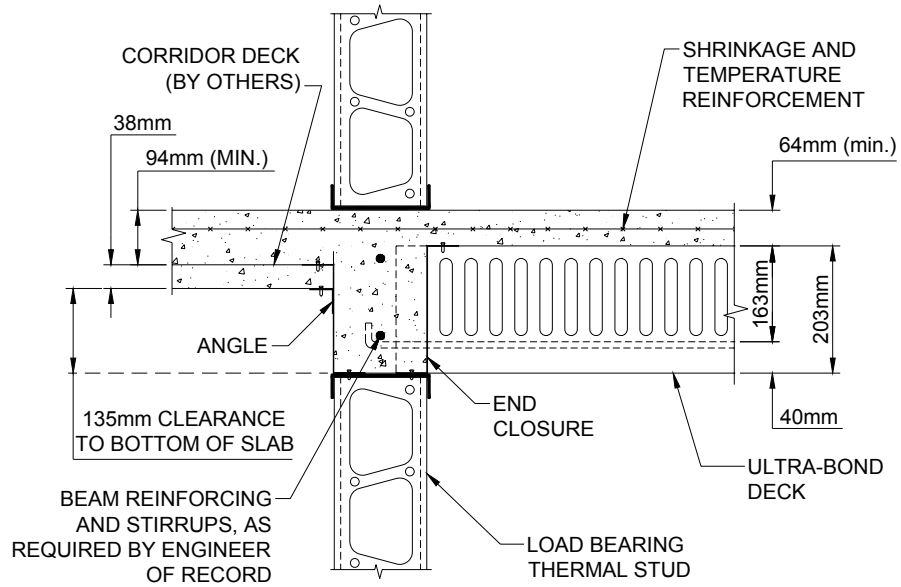

CORRIDOR BEARING DETAIL

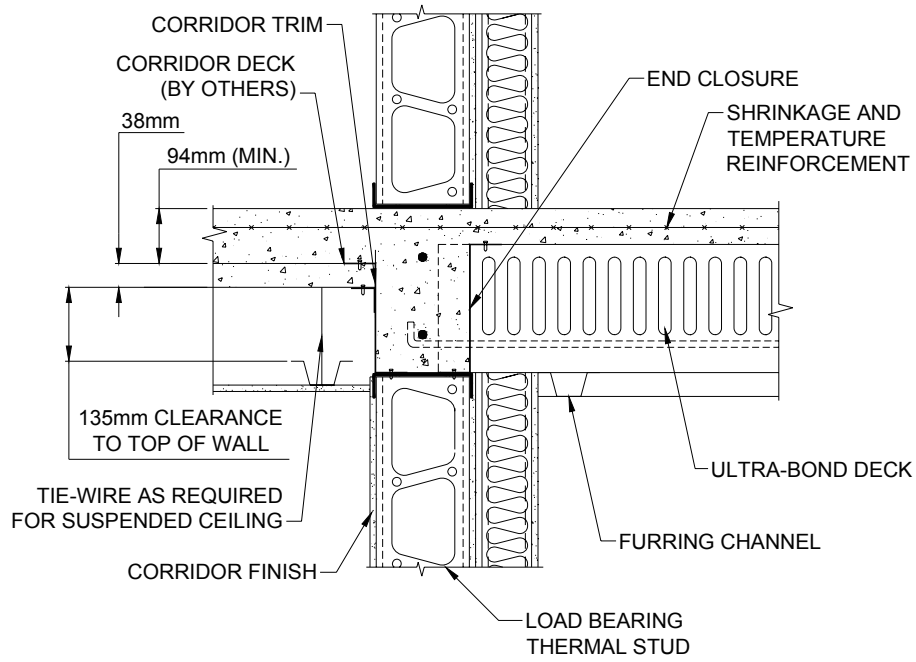

CORRIDOR FINISHING DETAIL

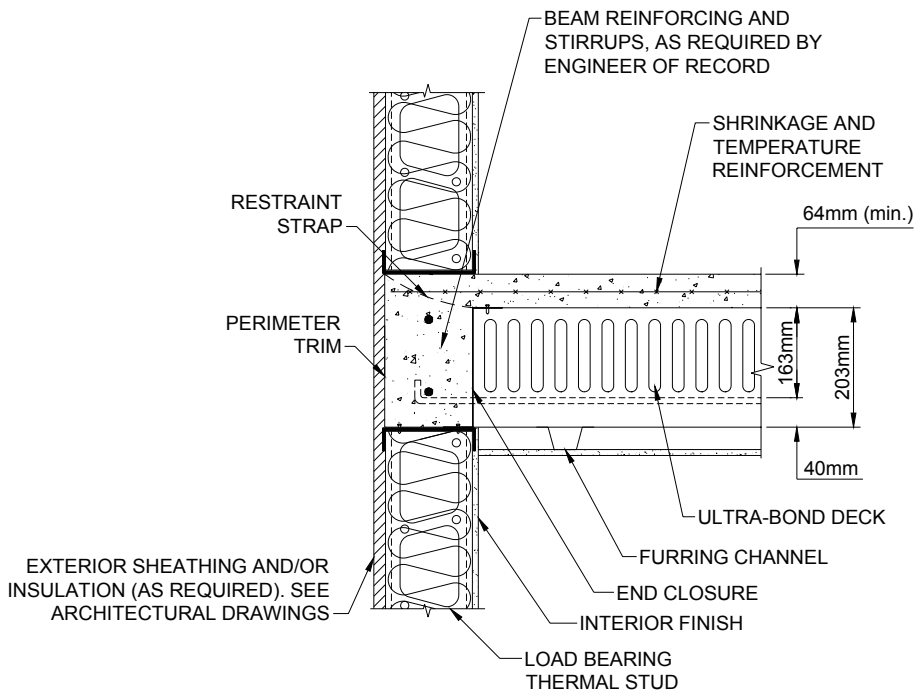

END BEARING FINISHING DETAIL

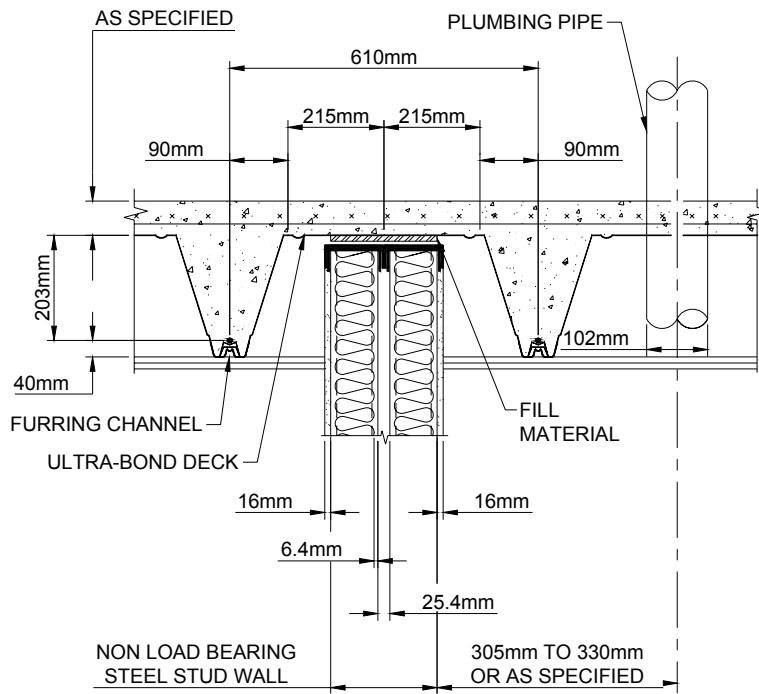
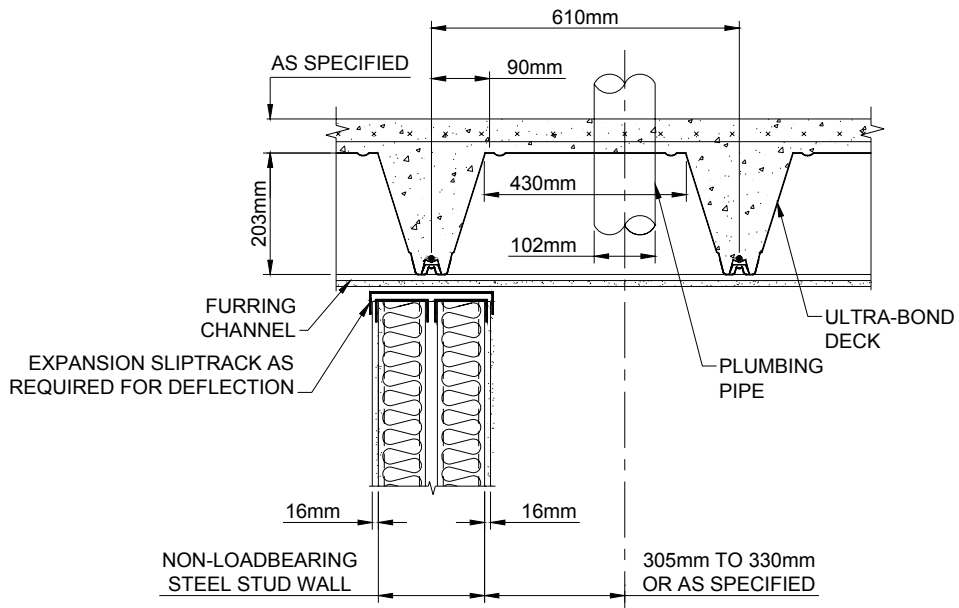

SUGGESTED CLEARANCE NEAR PLUMBING STACKS

**STEELFORM, ULTRA-BOND COMPOSITE
FLOOR DECK, DESIGN PROCEDURE
HOLE DIAMETERS ALLOWED**

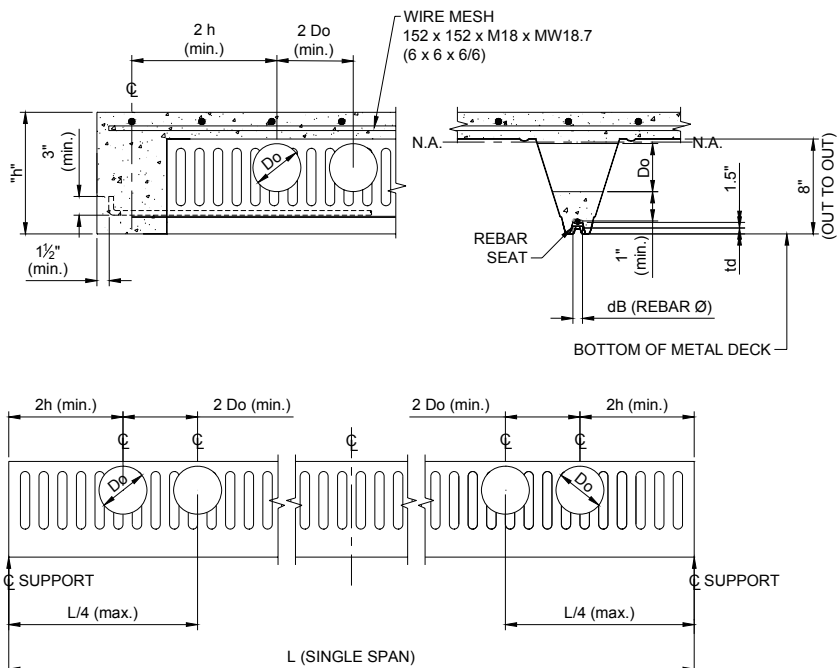

NOTATIONS:
h = OVERALL SLAB DEPTH
N.A. = NEUTRAL AXIS
Do = HOLE OPENING (MAX.)
dB = NOMINAL REBAR DIA.
td = METAL DECK THICKNESS

- NOTES:**
- (1) 25mm (1") OF CONCRETE COVER IS REQ'D ABOVE EACH REBAR (M IN.)
 - (2) THE CLEAR DISTANCE FROM BASE OF CONCRETE TO ϕ OF REBAR IS 1.5" (MIN.)
 - (3) NO MORE THAN TWO HOLES SHALL BE PLACED SIDE BY SIDE WITH THE END DISTANCE SPACING NOT LESS THAN 2h.
 - (4) THE SPACING BETWEEN ANY TWO HOLES SHALL NOT BE LESS THAN 2 Do.
 - (5) HOLES(S) SHALL BE POSITIONED AS SHOWN ABOVE (MAX L/4 FROM END SUPPORT).
 - (6) ONLY CIRCULAR HOLES ARE ACCEPTABLE AS SHOWN ABOVE.

TOTAL SLAB THICKNESS (H) (INCH)	REINFORCING STEEL BAR NOMIAL DIAMETER					HOLE DIAMETER IN (INCHES) (D)
	$d_B = 10\text{mm}$	$d_B = 15\text{mm}$	$d_B = 20\text{mm}$	$d_B = 25\text{mm}$	$d_B = 30\text{mm}$	
10.5	4.75	4.50	4.25	3.75	3.25	
11.0	5.25	4.75	4.50	4.00	3.75	
11.5	5.50	5.25	5.00	4.50	4.00	
12.0	6.00	5.75	5.25	5.00	4.50	
12.5	6.50	6.00	5.75	5.25	4.75	
13.0	6.75	6.50	6.25	5.75	5.25	
13.5	7.25	7.00	6.50	6.00	5.75	
14.0	7.75	7.25	7.00	6.50	6.00	

TOTAL SLAB THICKNESS (H) (mm)	REINFORCING STEEL BAR NOMIAL DIAMETER					HOLE DIAMETER IN (mm) (D)
	$d_B = 10\text{mm}$	$d_B = 15\text{mm}$	$d_B = 20\text{mm}$	$d_B = 25\text{mm}$	$d_B = 30\text{mm}$	
267	121	114	108	95	83	
279	133	121	114	102	95	
292	140	133	127	114	102	
305	152	146	133	127	114	
318	165	152	146	133	121	
330	171	165	159	146	133	
343	184	178	165	152	146	
356	197	184	178	165	152	

Construction Loads

In addition to the weight of the concrete and metal deck, at the time of concrete pouring, the following loads are normally allowed for:

- Uniform construction load of 1.0 kPa.
- Line load of 2.0 kN/m.

In order to keep construction loads to these limits, the following should be adhered to while placing the concrete:

- The concrete should be poured from a low level in order to avoid any impacting on the deck.
- The concrete should be placed uniformly over the supporting structure with minimal pile-up. It should be spread towards the center of the span.
- To minimize the possibility of the deck side-lap opening, sheet metal screws must be used to stitch side-laps.
- If buggies are used for concrete placement, adequate planking should be used as runways. Buggy movement should be restricted to these runways. The planks must be stiff and broad enough to distribute the load without damaging the deck.
- Shoring spacing must not exceed the unshored span shown in the Load Tables' Output Section #1.

Composite Loading

Design of the composite floor after curing of the concrete is similar to a one-way slab with positive reinforcement. The specified load on the slab is assumed to be uniform and static. In accordance with NBCC 1995, Clause 4.1.6.10, a concentrated load of 9 kN distributed over 750 mm is checked for. This load is taken as acting separately from the uniform loading. If there is heavy loading of a concentrated and/or dynamic nature, the deck should be used as a concrete form only. In some cases, it may be adequate to add extra reinforcement to the slab.

Strength design is based on combined loads due to steel deck, wet concrete and reinforcing bar. Construction loads are applied separately as follows:

- 1 kPa (21 psf) uniform load,
- 2 kN/m (137 lb./ft.) transverse line load at center of span.

Two unshored span load conditions are shown:

- 1 kPa (21 psf),
- 2 kPa (42 psf).

COMPUTER PROGRAM

To generate the Steelform's Ultra-Bond Load Tables and Graphs, a computer Program is included with the CD ROM Disc. One can vary any input data as one may encounter and obtain appropriate output data. The Computer Program is limited to the two deck thickness of 0.960 mm (0.0378") and 1.21 mm (0.0476") and the bar size of 10 mm to 30 mm in the increments shown in the Load Tables as well as the fixed metal deck configuration. This is due to the complex relation when the reinforcing bar reaches its yield point and the concrete at the beam top has not yet reached its full compression strength; at that stage, the steel deck contributes to the required additional tension. The amount of this contribution varies with the steel bar diameter, its distance from the concrete top, and the thickness of the metal deck, the total (A_{so}) is considered. Where (A_{so}) is the final effective cross-sectional area in inch square (steel bar and deck contribution).

Examples for the Proper use of Steelform Ultra-Bond Load Tables

EXAMPLE # 1

INTRODUCTION:

- 1) Although the strength equations used in generating the Load Tables are based on Limit State Design (LSD), with factor coefficients of $DL = 1.25$ for Dead Load and $LL = 1.50$ for Live Load, in accordance with the *National Building Code of Canada 1995*, the structural load tables provide a maximum "Specified" uniformly distributed load in (PSF) or (kPa), established in accordance with CSSBI 12M-84 and CSSBI S3-88.
- 2) The dead weight of the steel deck, reinforcing bar, wire mesh and concrete have already been accounted for in the Load Tables.
- 3) Accurate prediction of concrete creep protection is complicated because of the many variables such as:
 - Strength and composition of concrete
 - Concrete curing temperature and humidity
 - Composite member size (span length to beam depth ratio)
(See item 4 below)
 - Age at loading (minimum allowed 28 days after pouring of concrete)
 - Magnitude of stress (See item 4 below)

When composite floor members are shored during construction, creep deflection increase can become a critical consideration in design, when long term loading is present.

The following values of concrete creep deformation "multiplier factor" to compute long-time deflection based on Yu and Winter as well as "ACI" is presented in Table (1Z).

Table: 1Z

Duration of Loading	"Multiplier Factor"		
	A's = 0	A's = 1/2 As	A's = As
1 month	1.58	1.42	1.27
3 months	1.95	1.77	1.55
6 months	2.17	1.95	1.69
1 year	2.42	2.08	1.78
2 years	2.65	2.15	1.80
5 years	2.95	2.21	1.82
ACI-Code	3.00	2.40	1.80

As = Cross Sectional Area (in²) of bottom slab tension steel reinforcing.

A's = Cross Sectional Area (in²) of top slab compression steel reinforcing.

The final values of the "multiplier factor" to account for concrete creep deflection rests with the engineer in charge of the project design.

- 4) Based on finite element analysis and in spite of inclusion of shrinkage and temperature reinforcing bars in the concrete's top layer, the design professionals using Steelform's Ultra-Bond Load Tables **must multiply by a factor of (0.90)** the shown allowable single span in the Load Tables for the concrete thickness of 4.5" to 6.0" (including 4.5" and 6.0") above the top of the metal deck and for maximum specified uniformly distributed loads of 150 and 200 PSF only. (See design example #3).
- 5) The Computer Generated Load Tables account for deflection criteria of L/360 if deflection governs, by providing an appropriate span. Deflection criteria are based on the "Specified" uniformly distributed load. For design professionals wishing to determine actual allowable span for any load condition of: concrete cover, bar diameter and thickness of metal deck, Table (1X) and Examples are provided.
- 6) Load Tables are provided in Imperial and Metric Units, for metal deck thickness of 0.0378" and 0.0476", bar diameter of 10 mm to 30 mm in increments of 5 mm and concrete cover above top of metal deck of 2.50" to 6.0" in increments of 0.50", for the following "Specified" uniformly distributed loads: 40, 45, 50, 55, 60, 65, 70, 80, 85, 90, 100, 110, 120, 130, 140, 145, 150, 200, 250, 300, 350, 400, 450 and 500 PSF. Material specifications as shown on page 3 of this Manual.

DESIGN EXAMPLE # 1

GIVEN:

- Steel deck, core thickness, 0.0476", $FY=40.6 \text{ ksi}$
- Reinforcing steel bar diameter 15.0 mm (0.591"), $FY=58.0 \text{ ksi}$
- Concrete, normal density 150 P.C.F., $f_c = 4.35 \text{ ksi}$
- Slab depth above metal deck (h_c) = 2.50"
- Single span between supports = 20.0' (single shore required)
- Specified superimposed loads:

Partitions:	15.0 PSF
Floor Finish:	<u>9.0 PSF</u>
TOTAL:	24.0 PSF = (DL_s)

- (a) **DETERMINE:** Maximum allowable specified uniformly distributed load (PSF).

SOLUTION USING LOAD TABLES:

From Table Appendix A, Page 7	$h_c = 2.50''$ Span = 20.16' (Allowable)	$L_s = 150 \text{ PSF}$ (From Load Table) (Allow maximum specified uniformly distributed load)
-------------------------------	--	--

$$L_{s1} = L_s - \left(\frac{1.25}{1.50} \right) DL_s$$

Therefore: $L_{s1} = 150 - (0.833)(24.0) = 130.00 \text{ PSF}$

- (b) **CHECK DEFLECTION CRITERIA OF:** L/360 and L/480 (use Table 1X)

$$L_D = \left[\frac{(43703.7)(I_d)}{(Was)(K)} \right]^{0.333}$$

	$K = 1.0$ (L/360)	From Table 1X
	$K = 1.333$ (L/480)	[$I_d = 38.66 \text{ in}^4$]

$$(L/360) L_{D1} = \left[\frac{(43703.7)(38.66)}{(150)(1.00)} \right]^{0.333} = 22.35' \quad \text{Was} = 150 \text{ PSF}$$

$$(L/480) L_{D2} = \left[\frac{(43703.7)(38.66)}{(150)(1.333)} \right]^{0.333} = 20.30' > 20.16' \text{ therefore } \underline{\text{Strength Governs}}$$

FIND: Allowable span

$$L_D = \left[\frac{(43703.7)(46.50)^{(Id)}}{(204)(1.0)^{(K)}} \right]^{0.333} = 21.45'$$

DESIGN EXAMPLE # 2 :

GIVEN:

- Live Load = 40 PSF (LL)
- Superimposed Dead Load = 24.0 PSF (DL_s)
- Single span required = 30.0'

(a) **DETERMINE:** most economical composite floor combination.

SOLUTIONS USING LOAD TABLES:

$$L_S = LL + 0.833 DL_S$$

Therefore: $L_S = 40 + (0.833)(24) = 60$ PSF

From Appendix E, Page 4

- Steel Deck, Core Thickness, 0.0378", F_y = 40.6 Ksi
- Reinforcing bar diameter 0.984" (25 mm), F_y = 58.0 Ksi
- Concrete, normal density 150 PCF, f_c = 4.35 Ksi
- Slab depth above metal deck (h_c) = 2.50"
- **Allowable span (single) between supports = 30.18' > 30.0' therefore OK**

(b) **CHECK DEFLECTION CRITERIA OF:** L/360 and L/480 (use Table 1X)

$$L_D = \left[\frac{(43703.7)(Id)}{(Was)(K)} \right]^{0.333}$$

$K = 1.0$ (L/360) From Table 1X
 $K = 1.333$ (L/480) [Id = 42.61 in⁴]
 $Was = 60$ PSF

$$(L/360) L_{D1} = \left[\frac{(43703.7)(42.61)}{(60)(1.0)} \right]^{0.333} = 31.32' > 30.18' \text{ therefore } \underline{\text{Strength Governs}}$$

$$(L/480) L_{D2} = \left[\frac{(43703.7)(42.61)}{(60)(1.333)} \right]^{0.333} = 28.46' < 30.18' \text{ therefore not good}$$

T_{ry} h_c = 3.5" I_d = 55.16 in⁴ From Table 1X therefore

$$L_{D2} = \left[\frac{(43703.7)(55.16)}{(60)(1.333)} \right]^{0.333} = 31.0' > 30.0' \quad \text{therefore (OK)}$$

From Appendix E, Page 4 Allowable $L_S = 30.07'$ (strength governs)

Therefore for L/480 deflection criteria use same as above, but $h_c = 3.50''$

DESIGN EXAMPLE #3 – (Creep of Concrete Criteria)

Given:

- Live Load = 130 P.S.F. (LL)
- Superimposed Dead Load = 24.0 P.S.F. (DL_s)
- Single Span Required = 26.0'

(a) Determine Most Economical Composite Floor Combination

SOLUTIONS USING LOAD TABLES:

$$L_S = LL + 0.833 DL_S$$

Therefore: $L_S = 130 + (0.833)(24) = 150 \text{ P.S.F.}$

From Appendix A Page 9:

- Steel Deck, Core Thickness 0.0476", FY = 40.6 Ksi
- Reinforcing Bar Dia. = 0.984" (25mm), FY = 58.0 Ksi
- Concrete, Normal Density 150 PCF., $f_c = 4.35 \text{ Ksi}$
- Slab Depth Above Metal Deck $h_c = 6.0''$
- Allowable Span (Single) Between Supports = $(29.09)(0.9) = 26.18' > 26.0'$
therefore (OK)

See Item 3 and 4, page 14 and 15

(0.9) = concrete creep span reduction coefficient

(b) **CHECK DEFLECTION CRITERIA OF:** L/480 and L/600 and L/360

$$L_D = \left[\frac{(43703.7)(I_d)}{(W_{as})(K)} \right]^{0.333}$$

K = 1.333 For Defl. (L/480) K = 1.0 For Defl (L/360)

K = 1.67 For Defl. (L/600)

From Table (1X) $I_d = 102.29 \text{ in}^4$
 $W_{as} = 150 \text{ PSF}$

$$\text{For (L/480) } L_{D1} = \left[\frac{(43703.7)(102.29)}{(150)(1.333)} \right]^{0.333} = 28.08' > 26.0' \text{ therefore (OK)}$$

$$\text{For (L/600) } L_{D2} = \left[\frac{(43703.7)(102.29)}{(150)(1.67)} \right]^{0.333} = 26.05' > 26.0' \text{ therefore (OK)}$$

Final Conclusion: 26.0' Span OK for Strength or L/600 Deflection

$$\text{For (L/360) } L_{D3} = \left[\frac{(43703.7)(102.29)}{(150)(1.0)} \right]^{0.333} = 30.85' > 29.09' \text{ therefore (OK)}$$

The structural Load Tables and technical information contained in this catalogue were prepared by Michael Sommerstein, P. Eng. M&H Engineering and Wendy Zhu, Ph.D., P.Eng., Bodycote Material Testing Canada Inc. on 14-Feb-05.

Link

<http://www.steelform.ca/ultrabond.asp>

CONSTRUCTION GUIDELINES

Decking Installation

Ultra-Bond Floor Decking shall be positively fastened to the supporting structure to avoid movement during construction and excessive deflection during placement of concrete. The fastening frequency of main fasteners is 1 per trough at each panel end at 610 mm (24 inches) on centre along the support structure. When fastening panels to structural steel work, use heavy duty shot fired pins or self-drilling fasteners designed and specified by the engineer of record. For brick, block and concrete, the decking shall be fastened using adequate masonry fasteners as designed and specified by the engineer of record. In addition to the main fasteners, the top flanges of the end diaphragm closures shall be fastened to the decking, one fastener per module, either centered or 610 mm (24 inches) on centre. Side-lap washers shall be fastened at 350 mm (13.8 inches) centres along the bottom trough. The location of the fasteners is pre-punched on the male trough flange, which overlaps the female trough flange. Use self-drilling fasteners with a minimum 5.5 mm (0.217 inches) diameter.

Note # 1: Every side-lap fastener shall include a side-lap washer. This washer is required to properly attach the individual steel deck panels together.

Note # 2: When a suspended ceiling is used, the minimum thread length of the fastener is 25 mm (1 inch).

The bottom flange of the end closure shall be fastened to the supporting structure with 1 fastener per module at 610 mm (24 inches) on centre or as specified by the engineer of record.

Restraint Straps

The top of the perimeter trim is connected to the decking with restraint straps at approximately 400 mm (15.75 inches) on centre using either pop rivets or self-drilling fasteners. The restraint strap can be adjusted to suit the pitch and alignment of the perimeter trim.

Penetrations

Penetrations through the floor decking shall be cut after the concrete has cured. Before placing concrete, any openings shall be boxed out with form work as specified by the engineer of record. The following guidelines are suggested for isolated openings at right angles to the deck span, or as specified by the engineer of record.

- Up to 300 mm (12 inches) square penetrations centered on the top of the profile deck is acceptable without additional reinforcement, other than the minimum shrinkage and temperature mesh.
- Up to 425 mm (16.7 inches) width by 1,000 mm (39.4 inches) length opening, additional light gauge reinforcements are required.
- Openings larger than 425 mm (16.7 inches) require structural steel framing as specified by the engineer of record.
- Close grouping of openings transverse to the profile shall be treated as one opening, requiring additional reinforcement as specified by the engineer of record.
- After the slab has reached 75% of the required concrete compressive strength, a nibbler, power saw or coring machine can be used to cut openings in the top profile with the approval by the engineer of record.

Care shall be taken to avoid concrete heaping in any area during concrete placement. Typical construction live loads have been accounted for in the load tables. Should additional construction loading be required, approval by the engineer of record is required.

Temporary Supports

When the design span exceeds the maximum unshored span shown in the load tables, the wet concrete weight and construction loads shall be supported by adding temporary supports (shoring), as designed by the engineer of record. Where temporary supports are required it is important that:

- Beams and the support structure have adequate strength to support the construction loads as designed and specified by the engineer of record.
- Shoring is normally placed at mid span or at other suitable intervals as required.
- Shoring beams shall provide a minimum bearing width of 100 mm (4 inches).
- The shoring structure shall remain in place until the concrete has reached 75% of its design strength, or as specified by the engineer of record.

Hanger System

The magnitude and spacing of the suspended loads carried by the Steelform Ultra-Bond Composite System must be evaluated by the engineer of record to ensure that the composite system can carry it safely. This includes proper connections.

End Closures

To minimize grout loss at the profile ends during concrete placement, end closures are provided to contain the concrete. These closures are manufactured from 54 mil galvanized steel, generally 1830 mm (6 feet) long or longer for angle cut installations. End closures shall be fastened to the support structure with a minimum of 2 fasteners (such as shot-fired pins or self-drilling fasteners), or as specified by the engineer of record. Apart from minimizing grout loss during concrete placement, these end closures provide strength to assist prevention of web crippling of the steel deck and proper alignment of the decking during construction. When used in conjunction with hot rolled steel beams, these end closures provide concrete cover to the beam for fire resistance.

Side-lap Washers

Since the Ultra-Bond Floor Deck acts in part compositely with concrete, side-lap washers are important connecting elements. These washers are pre-punched to receive the self-drilling fastener.

Cantilevers

Ultra-Bond Floor Deck can be end cantilevered. When side cantilevers are required, stub beams or brackets shall be provided by the structural steel fabricator, as designed by the engineer of record. Cantilevers shall also be assessed for positive and negative reinforcement by the engineer of record.

Perimeter Edge Trims

Are required for the retention of wet concrete to the correct level at the decked floor perimeters and designed openings. They are supplied in 3 m (10 feet) lengths of galvanized steel. The trims are usually fastened by shot-fired pins to the structural steel or by self-drilling fasteners to the support structure at 610 mm (24 inches) on centre, or as specified by the engineer of record.

Columns and Ultra-Bond Floor Decking

The steel deck sheeting can be cut and fitted to accommodate various column shapes to minimize grout loss. Where no supporting steel work is provided, steel angle brackets shall be provided to support the steel decking, as specified by the engineer of record.

Rib Reinforcement and Mesh Placement

The Ultra-Bond Floor Deck design requires that one steel reinforcing bar be placed in each rib profile. The bar size, as shown in the load tables, can vary from 10 mm (0.394 inches) to 30 mm (1.18 inches) in diameter. The bars shall be placed on bar supports 40 mm (1.57 inches) above the rib profile bottom flange. This ensures 40 mm (1.57 inches) spacing from the bottom flange to the underside of the reinforcing bars.

Spacing of the reinforcing bar supports shall be in accordance with good practice guidelines, and not exceeding 1220 mm (48 inches) on centre. To ensure both vertical and horizontal stability during concrete placement, the reinforcing bars shall be tied down periodically through side-lap washers with 1.21 mm (0.0476 inches) diameter tie wiring. It is recommended that a minimum standard shrinkage and temperature reinforcing mesh of 152 x 152 x MW18.7 x MW18.7 (6 x 6 x 6/6) be placed above the top of the steel decking and positioned towards the top of the slab, or as specified by the engineer of record.

Concrete Placement

Concrete shall be placed in accordance with CAN/CSA A23.1-94. Before starting concrete placement, the steel decking shall be cleared of dirt, grease and debris, which could adversely influence the composite slab performance.

Service Holes

Refer to table on page 12 for size and location of round holes through Ultra-Bond Floor Deck ribs. Sleeves shall be fastened in place before concrete placement. Cut-out of



holes shall be done only after the concrete has reached 75% of its design strength, or as specified by the engineer of record.

Ceiling Hanger System

Ceilings can be suspended directly from the self-drilling side-lap fasteners in the decking troughs, which at 610 mm (24 inches) centres, are ideally lined up for standard ceiling tile grids (consult with the engineer of record for hardware approval).

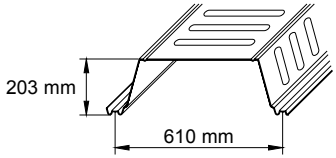
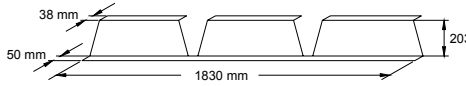
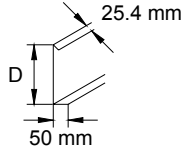
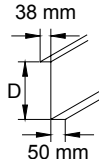
Trims and Accessories

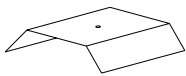
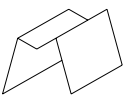
MATERIALS	THICKNESS		WEIGHT		PACKAGING
	mm	inches	SI-Metric	Imperial	Pieces
ULTRA-BOND FLOOR DECK 	0.96	0.0378	0.124 KpA	2.59 PSF	20 pcs/bundle or as per request – cut to length.
	1.21	0.0476	0.155 KpA	3.24 PSF	
END CLOSURES 	1.52	0.0600	2.98 kg/m	2 lb/ft	50 pcs/bundle
	1.52	0.0600	5.44 kg/pc	12 lb/pc	Custom angles available upon request.
PERIMETER TRIMS 	1.52	0.0600	17.7 kg/pc	39 lb/pc	10 pcs/bundle
			20.4 kg/pc	45 lb/pc	10 foot lengths
INSIDE TRIMS 	1.52	0.0600	13.6 kg/pc	30 lb/pc	10 pcs/bundle
	1.22	0.048	11.3 kg/pc	25 lb/pc	
	0.914	0.036	9.1 kg/pc	20 lb/pc	10 foot lengths

<p>SIDE LAP WASHERS</p> 	1.22	0.048	11.3 kg/pc	25 lb/pc	500 pcs/ctn
<p>REBAR SUPPORTS</p> 	0.914	0.036	20.4 kg/pc	45 lb/pc	300 pcs/ctn
<p>RESTRAINT STRAPS</p> 	0.914	0.036	9.1 kg/pc	20 lb/pc	100 pcs/ctn
<p>FASTENERS</p> <p>#12 x 1" Hex Self-Drilling Zinc.</p>			20.4 kg/pc	45 lb/pc	3000 pcs/ctn



ULTRA-BOND COMPOSITE FLOOR DECK
 MAXIMUM SPECIFIED UNIFORMLY DISTRIBUTED LOAD (P.S.F)
 INCLUDES DEAD AND CONSTRUCTION LOAD CARRIED
 BY METAL DECK *(NOT SHOWN IN TABLES)*
 LIMIT STATE DESIGN (LSD) - IMPERIAL UNITS

0.0476" Deck
0.394" Rebar

INPUT SECTION:

ITEM	DESCRIPTION OR SECTION PROPERTIES	CONCRETE COVER ABOVE TOP OF METAL DECK (hf) OR (hc) (IN)							
		2.50	3.00	3.50	4.00	4.50	5.00	5.50	6.00
A	METAL DECK THICK (INCH) (Td)	0.0476	0.0476	0.0476	0.0476	0.0476	0.0476	0.0476	0.0476
B	METAL DECK YIELD STRENGTH (KSI)(Fy)	40.6	40.6	40.6	40.6	40.6	40.6	40.6	40.6
C	METAL DECK EFF. (Ix) (IN ⁴)/FT	5.09	5.09	5.09	5.09	5.09	5.09	5.09	5.09
D	METAL DECK EFF. (Sx) (IN ³)/FT	1.15	1.15	1.15	1.15	1.15	1.15	1.15	1.15
E	METAL DECK (Es)(PSI)	2.95E+07	2.95E+07	2.95E+07	2.95E+07	2.95E+07	2.95E+07	2.95E+07	2.95E+07
F	# REINFORCING STEEL BAR DIA. (INCH)	0.394	0.394	0.394	0.394	0.394	0.394	0.394	0.394
G	CONCRETE STRENGTH (f'c) (PSI)	4350	4350	4350	4350	4350	4350	4350	4350
H	CONCRETE (Ec) (PSI)	3.80E+06	3.80E+06	3.80E+06	3.80E+06	3.80E+06	3.80E+06	3.80E+06	3.80E+06
I	A _F (IN ²)/FT	0.865	0.865	0.865	0.865	0.865	0.865	0.865	0.865
J	I _{x(F)} (IN ⁴)/FT	7.18	7.18	7.18	7.18	7.18	7.18	7.18	7.18
K	ALLOWABLE FORCE (LBS/FT)	659	659	659	659	659	659	659	659
L	FINAL EFF. CROSS SECT. AREA A _{SO} (IN ²)	0.467	0.467	0.467	0.467	0.467	0.467	0.467	0.467
M	DEFLECTION CRITERIA K _{1,2,3,4}	1.333	1.333	1.333	1.333	1.333	1.333	1.333	1.333
N	DEFLECTION CRITERIA *	L/480	L/480	L/480	L/480	L/480	L/480	L/480	L/480

* DEFLECTION CRITERIA: L/360 (K₁=1), L/480 (K₂=1.333), L/600 (K₃=1.670) OR L/720 (K₄=2.0)
 # REINFORCING BAR Fy0=58.0KSI

OUTPUT SECTION #1

ITEM	DESCRIPTION	CONCRETE COVER ABOVE TOP OF METAL DECK (hf) OR (hc) (IN)							
		2.50	3.00	3.50	4.00	4.50	5.00	5.50	6.00
O	MAX. UNSHORED SPAN (C.L.21PSF).FT.	14.18	13.08	12.14	11.32	10.61	9.98	9.43	8.93
P	MAX. UNSHORED SPAN (C.L.42PSF).FT.	10.38	9.86	9.78	9.24	8.76	8.33	7.94	7.58
Q	TOTAL DEAD LOAD (NO CONST.).PSF.	53.37	59.62	65.87	72.11	78.36	84.61	90.86	97.10
R	CONCRETE VOLUME. YD ³ /100FT ²	1.240	1.394	1.549	1.703	1.857	2.011	2.166	2.320

C.L. = CONSTRUCTION LOAD (PSF)

OUTPUT SECTION #2: PLOT DATA - AND INPUT SECTION AS SHOWN #

ITEM	DESCRIPTION	(hf) OR (hc) (IN)	# MAXIMUM SPECIFIED UNIFORMLY DISTRIBUTED LOAD (P.S.F)							
			40	45	50	55	60	65	70	80
1	ALLOW. SINGLE UNSUP. SPAN - FT.	2.50	25.89	25.30	24.75	24.24	23.76	23.30	22.87	22.08
2	ALLOW. SINGLE UNSUP. SPAN - FT.	3.00	25.69	25.14	24.63	24.15	23.70	23.27	22.87	22.11
3	ALLOW. SINGLE UNSUP. SPAN - FT.	3.50	25.51	25.01	24.53	24.08	23.65	23.25	22.86	22.15
4	ALLOW. SINGLE UNSUP. SPAN - FT.	4.00	25.36	24.89	24.44	24.01	23.61	23.23	22.86	22.18
5	ALLOW. SINGLE UNSUP. SPAN - FT.	4.50	25.22	24.78	24.35	23.95	23.57	23.21	22.86	22.21
6	ALLOW. SINGLE UNSUP. SPAN - FT.	5.00	25.10	24.68	24.28	23.90	23.54	23.19	22.86	22.23
7	ALLOW. SINGLE UNSUP. SPAN - FT.	5.50	24.99	24.59	24.21	23.85	23.50	23.17	22.85	22.26
8	ALLOW. SINGLE UNSUP. SPAN - FT.	6.00	24.89	24.51	24.15	23.80	23.47	23.16	22.85	22.28

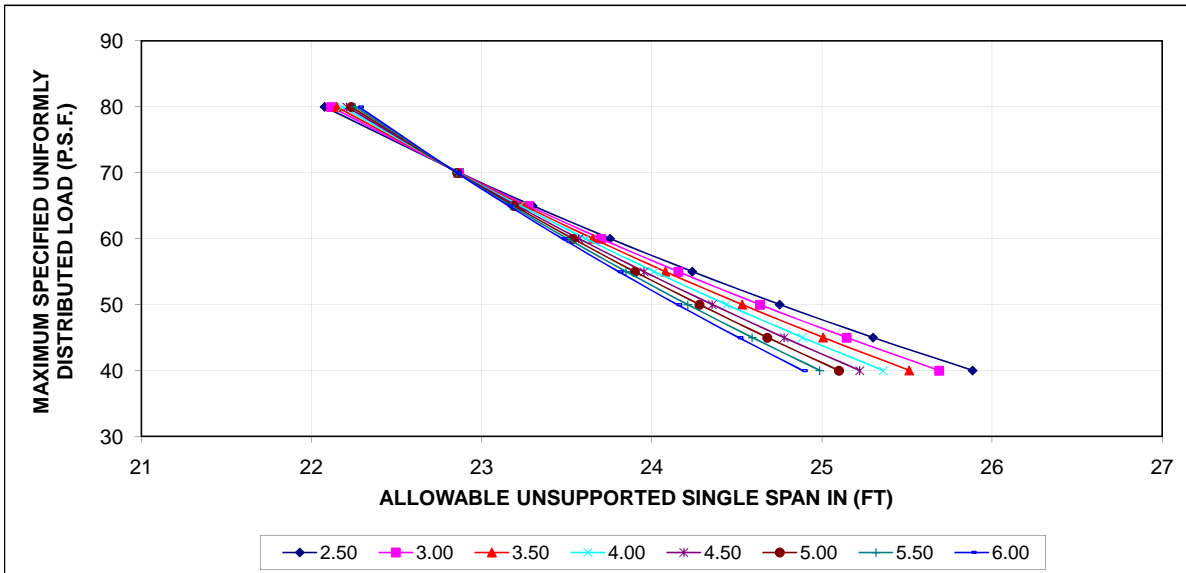



ULTRA-BOND COMPOSITE FLOOR DECK
 MAXIMUM SPECIFIED UNIFORMLY DISTRIBUTED LOAD (P.S.F)
 INCLUDES DEAD AND CONSTRUCTION LOAD CARRIED
 BY METAL DECK *(NOT SHOWN IN TABLES)*
 LIMIT STATE DESIGN (LSD) - IMPERIAL UNITS

0.0476" Deck
0.787" Rebar

INPUT SECTION:

ITEM	DESCRIPTION OR SECTION PROPERTIES	CONCRETE COVER ABOVE TOP OF METAL DECK (hf) OR (hc) (IN)							
		2.50	3.00	3.50	4.00	4.50	5.00	5.50	6.00
A	METAL DECK THICK (INCH) (Td)	0.0476	0.0476	0.0476	0.0476	0.0476	0.0476	0.0476	0.0476
B	METAL DECK YIELD STRENGTH (KSI)(Fy)	40.6	40.6	40.6	40.6	40.6	40.6	40.6	40.6
C	METAL DECK EFF. (Ix) (IN ⁴)/FT	5.09	5.09	5.09	5.09	5.09	5.09	5.09	5.09
D	METAL DECK EFF. (Sx) (IN ³)/FT	1.15	1.15	1.15	1.15	1.15	1.15	1.15	1.15
E	METAL DECK (Es)(PSI)	2.95E+07	2.95E+07	2.95E+07	2.95E+07	2.95E+07	2.95E+07	2.95E+07	2.95E+07
F	# REINFORCING STEEL BAR DIA. (INCH)	0.787	0.787	0.787	0.787	0.787	0.787	0.787	0.787
G	CONCRETE STRENGTH (f'c) (PSI)	4350	4350	4350	4350	4350	4350	4350	4350
H	CONCRETE (Ec) (PSI)	3.80E+06	3.80E+06	3.80E+06	3.80E+06	3.80E+06	3.80E+06	3.80E+06	3.80E+06
I	A _F (IN ²)/FT	0.865	0.865	0.865	0.865	0.865	0.865	0.865	0.865
J	I _{x(F)} (IN ⁴)/FT	7.18	7.18	7.18	7.18	7.18	7.18	7.18	7.18
K	ALLOWABLE FORCE (LBS/FT)	659	659	659	659	659	659	659	659
L	FINAL EFF. CROSS SECT. AREA A _{EO} (IN ²)	0.672	0.672	0.672	0.672	0.672	0.672	0.672	0.672
M	DEFLECTION CRITERIA K _{1,2,3,4}	1.333	1.333	1.333	1.333	1.333	1.333	1.333	1.333
N	DEFLECTION CRITERIA *	L/480	L/480	L/480	L/480	L/480	L/480	L/480	L/480

* DEFLECTION CRITERIA: L/360 (K₁=1), L/480 (K₂=1.333), L/600 (K₃=1.670) OR L/720 (K₄=2.0)
 # REINFORCING BAR Fy0=58.0KSI

OUTPUT SECTION #1

ITEM	DESCRIPTION	CONCRETE COVER ABOVE TOP OF METAL DECK (hf) OR (hc) (IN)							
		2.50	3.00	3.50	4.00	4.50	5.00	5.50	6.00
O	MAX. UNSHORED SPAN (C.L.21PSF).FT.	14.13	13.04	12.10	11.29	10.59	9.96	9.41	8.91
P	MAX. UNSHORED SPAN (C.L.42PSF).FT.	10.35	9.90	9.75	9.22	8.74	8.31	7.92	7.57
Q	TOTAL DEAD LOAD (NO CONST.).PSF.	53.61	59.86	66.11	72.35	78.60	84.85	91.10	97.34
R	CONCRETE VOLUME. YD ³ /100FT ²	1.231	1.385	1.539	1.693	1.848	2.002	2.156	2.310

C.L. = CONSTRUCTION LOAD (PSF)

OUTPUT SECTION #2: PLOT DATA - AND INPUT SECTION AS SHOWN #

ITEM	DESCRIPTION	(hf) OR (hc) (IN)	# MAXIMUM SPECIFIED UNIFORMLY DISTRIBUTED LOAD (P.S.F)							
			40	45	50	55	60	65	70	80
1	ALLOW. SINGLE UNSUP. SPAN - FT.	2.50	30.89	30.19	29.54	28.93	28.35	27.81	27.30	26.13
2	ALLOW. SINGLE UNSUP. SPAN - FT.	3.00	30.66	30.02	29.41	28.84	28.30	27.79	27.30	26.41
3	ALLOW. SINGLE UNSUP. SPAN - FT.	3.50	30.46	29.86	29.29	28.76	28.25	27.76	27.31	26.45
4	ALLOW. SINGLE UNSUP. SPAN - FT.	4.00	30.29	29.72	29.19	28.68	28.20	27.74	27.31	26.50
5	ALLOW. SINGLE UNSUP. SPAN - FT.	4.50	30.13	29.60	29.09	28.62	28.16	27.73	27.31	26.53
6	ALLOW. SINGLE UNSUP. SPAN - FT.	5.00	29.99	29.49	29.01	28.56	28.12	27.71	27.31	26.57
7	ALLOW. SINGLE UNSUP. SPAN - FT.	5.50	29.86	29.39	28.93	28.50	28.09	27.69	27.32	26.60
8	ALLOW. SINGLE UNSUP. SPAN - FT.	6.00	29.74	29.29	28.86	28.45	28.06	27.68	27.32	26.63

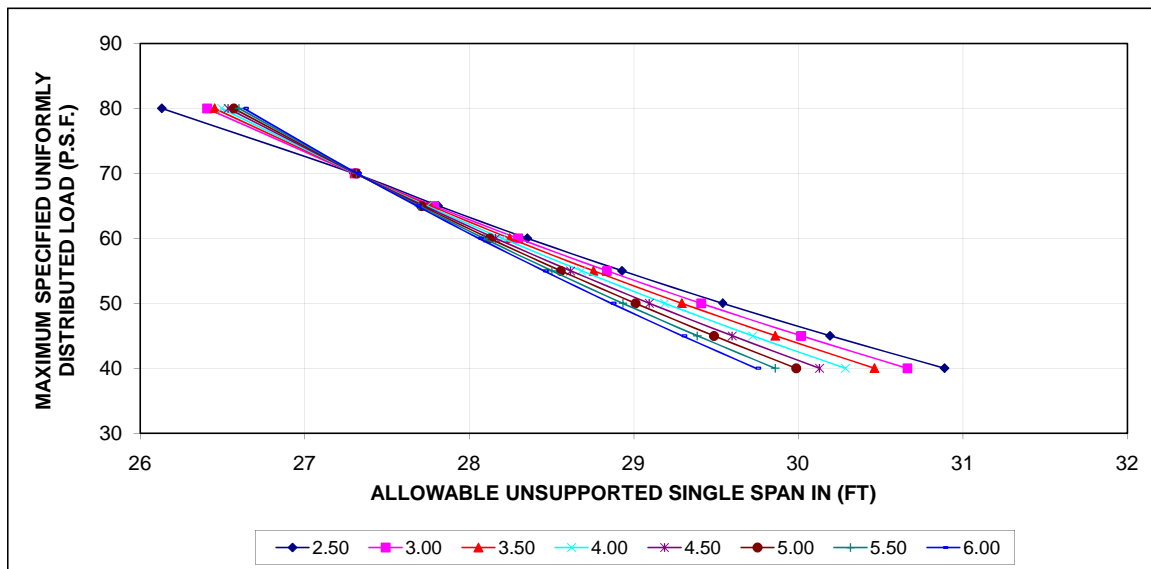



ULTRA-BOND COMPOSITE FLOOR DECK
 MAXIMUM SPECIFIED UNIFORMLY DISTRIBUTED LOAD (P.S.F)
 INCLUDES DEAD AND CONSTRUCTION LOAD CARRIED
 BY METAL DECK *(NOT SHOWN IN TABLES)*
 LIMIT STATE DESIGN (LSD) - **IMPERIAL UNITS**

0.0476" Deck
0.984" Rebar

INPUT SECTION:

ITEM	DESCRIPTION OR SECTION PROPERTIES	CONCRETE COVER ABOVE TOP OF METAL DECK (hf) OR (hc) (IN)							
		2.50	3.00	3.50	4.00	4.50	5.00	5.50	6.00
A	METAL DECK THICK (INCH) (Td)	0.0476	0.0476	0.0476	0.0476	0.0476	0.0476	0.0476	0.0476
B	METAL DECK YIELD STRENGTH (KSI)(Fy)	40.6	40.6	40.6	40.6	40.6	40.6	40.6	40.6
C	METAL DECK EFF. (Ix) (IN ⁴)/FT	5.09	5.09	5.09	5.09	5.09	5.09	5.09	5.09
D	METAL DECK EFF. (Sx) (IN ³)/FT	1.15	1.15	1.15	1.15	1.15	1.15	1.15	1.15
E	METAL DECK (Es)(PSI)	2.95E+07	2.95E+07	2.95E+07	2.95E+07	2.95E+07	2.95E+07	2.95E+07	2.95E+07
F	# REINFORCING STEEL BAR DIA. (INCH)	0.984	0.984	0.984	0.984	0.984	0.984	0.984	0.984
G	CONCRETE STRENGTH (f'c) (PSI)	4350	4350	4350	4350	4350	4350	4350	4350
H	CONCRETE (Ec) (PSI)	3.80E+06	3.80E+06	3.80E+06	3.80E+06	3.80E+06	3.80E+06	3.80E+06	3.80E+06
I	A _F (IN ²)/FT	0.865	0.865	0.865	0.865	0.865	0.865	0.865	0.865
J	I _{x(F)} (IN ⁴)/FT	7.18	7.18	7.18	7.18	7.18	7.18	7.18	7.18
K	ALLOWABLE FORCE (LBS/FT)	659	659	659	659	659	659	659	659
L	FINAL EFF. CROSS SECT. AREA A _{SO} (IN ²)	0.900	0.900	0.900	0.900	0.900	0.900	0.900	0.900
M	DEFLECTION CRITERIA K _{1,2,3,4}	1.333	1.333	1.333	1.333	1.333	1.333	1.333	1.333
N	DEFLECTION CRITERIA *	L/480	L/480	L/480	L/480	L/480	L/480	L/480	L/480

* DEFLECTION CRITERIA: L/360 (K₁=1), L/480 (K₂=1.333), L/600 (K₃=1.670) OR L/720 (K₄=2.0)
 # REINFORCING BAR Fy0=58.0KSI

OUTPUT SECTION #1

ITEM	DESCRIPTION	CONCRETE COVER ABOVE TOP OF METAL DECK (hf) OR (hc) (IN)							
		2.50	3.00	3.50	4.00	4.50	5.00	5.50	6.00
O	MAX. UNSHORED SPAN (C.L.21PSF).FT.	14.10	13.01	12.08	11.27	10.57	9.94	9.39	8.90
P	MAX. UNSHORED SPAN (C.L.42PSF).FT.	10.33	9.92	9.74	9.21	8.73	8.30	7.91	7.56
Q	TOTAL DEAD LOAD (NO CONST.) PSF.	53.79	60.04	66.29	72.54	78.78	85.03	91.28	97.53
R	CONCRETE VOLUME. YD ³ /100FT ²	1.224	1.378	1.532	1.686	1.841	1.995	2.149	2.303

C.L. = CONSTRUCTION LOAD (PSF)

OUTPUT SECTION #2: PLOT DATA - AND INPUT SECTION AS SHOWN #

ITEM	DESCRIPTION	(hf) OR (hc) (IN)	# MAXIMUM SPECIFIED UNIFORMLY DISTRIBUTED LOAD (P.S.F)							
			40	45	50	55	60	65	70	80
1	ALLOW. SINGLE UNSUP. SPAN - FT.	2.50	33.21	31.94	30.84	29.87	29.02	28.26	27.57	26.37
2	ALLOW. SINGLE UNSUP. SPAN - FT.	3.00	34.94	33.60	32.44	31.43	30.53	29.72	29.00	27.74
3	ALLOW. SINGLE UNSUP. SPAN - FT.	3.50	35.09	34.39	33.74	32.98	32.03	31.19	30.43	29.11
4	ALLOW. SINGLE UNSUP. SPAN - FT.	4.00	34.89	34.24	33.63	33.05	32.49	31.97	31.47	30.48
5	ALLOW. SINGLE UNSUP. SPAN - FT.	4.50	34.72	34.11	33.53	32.98	32.45	31.95	31.48	30.58
6	ALLOW. SINGLE UNSUP. SPAN - FT.	5.00	34.56	33.99	33.44	32.91	32.42	31.94	31.48	30.63
7	ALLOW. SINGLE UNSUP. SPAN - FT.	5.50	34.42	33.88	33.36	32.86	32.38	31.93	31.49	30.67
8	ALLOW. SINGLE UNSUP. SPAN - FT.	6.00	34.29	33.77	33.28	32.81	32.35	31.92	31.50	30.71

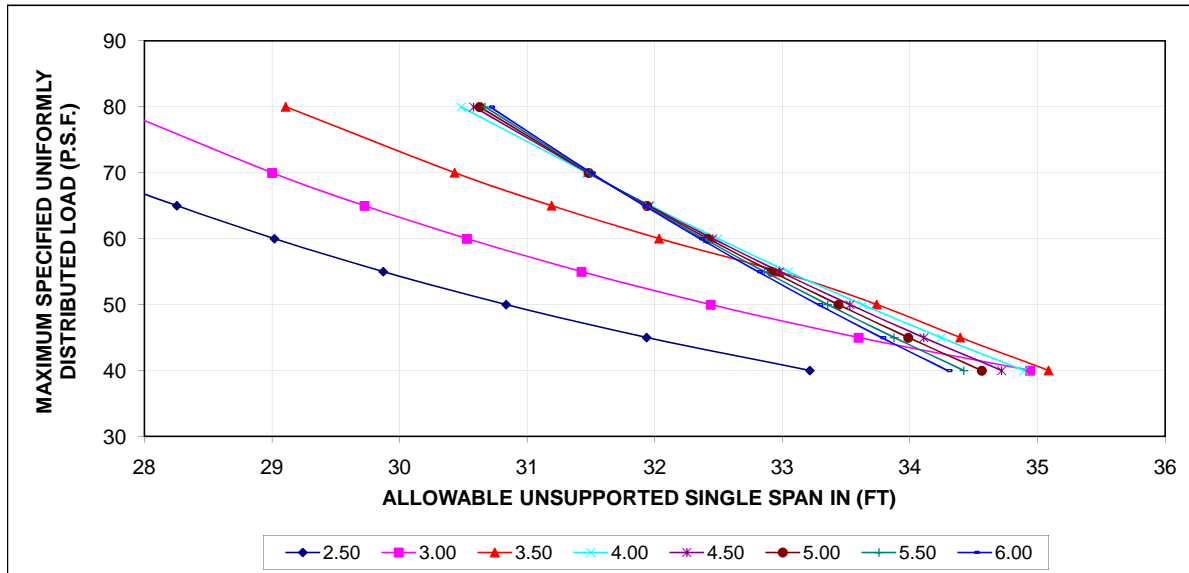



ULTRA-BOND COMPOSITE FLOOR DECK
 MAXIMUM SPECIFIED UNIFORMLY DISTRIBUTED LOAD (P.S.F)
 INCLUDES DEAD AND CONSTRUCTION LOAD CARRIED
 BY METAL DECK *(NOT SHOWN IN TABLES)*
 LIMIT STATE DESIGN (LSD) - IMPERIAL UNITS

0.0476" Deck
1.181" Rebar

INPUT SECTION:

ITEM	DESCRIPTION OR SECTION PROPERTIES	CONCRETE COVER ABOVE TOP OF METAL DECK (hf) OR (hc) (IN)							
		2.50	3.00	3.50	4.00	4.50	5.00	5.50	6.00
A	METAL DECK THICK (INCH) (Td)	0.0476	0.0476	0.0476	0.0476	0.0476	0.0476	0.0476	0.0476
B	METAL DECK YIELD STRENGTH (KSI)(Fy)	40.6	40.6	40.6	40.6	40.6	40.6	40.6	40.6
C	METAL DECK EFF. (Ix) (IN ⁴)/FT	5.09	5.09	5.09	5.09	5.09	5.09	5.09	5.09
D	METAL DECK EFF. (Sx) (IN ³)/FT	1.15	1.15	1.15	1.15	1.15	1.15	1.15	1.15
E	METAL DECK (Es)(PSI)	2.95E+07	2.95E+07	2.95E+07	2.95E+07	2.95E+07	2.95E+07	2.95E+07	2.95E+07
F	# REINFORCING STEEL BAR DIA. (INCH)	1.181	1.181	1.181	1.181	1.181	1.181	1.181	1.181
G	CONCRETE STRENGTH (f'c) (PSI)	4350	4350	4350	4350	4350	4350	4350	4350
H	CONCRETE (Ec) (PSI)	3.80E+06	3.80E+06	3.80E+06	3.80E+06	3.80E+06	3.80E+06	3.80E+06	3.80E+06
I	A _F (IN ²)/FT	0.865	0.865	0.865	0.865	0.865	0.865	0.865	0.865
J	I _{x(F)} (IN ⁴)/FT	7.18	7.18	7.18	7.18	7.18	7.18	7.18	7.18
K	ALLOWABLE FORCE (LBS/FT)	659	659	659	659	659	659	659	659
L	FINAL EFF. CROSS SECT. AREA A _{SO} (IN ²)	1.095	1.095	1.095	1.095	1.095	1.095	1.095	1.095
M	DEFLECTION CRITERIA K _{1,2,3,4}	1.333	1.333	1.333	1.333	1.333	1.333	1.333	1.333
N	DEFLECTION CRITERIA *	L/480	L/480	L/480	L/480	L/480	L/480	L/480	L/480

* DEFLECTION CRITERIA: L/360 (K₁=1), L/480 (K₂=1.333), L/600 (K₃=1.670) OR L/720 (K₄=2.0)
 # REINFORCING BAR Fy0=58.0KSI

OUTPUT SECTION #1

ITEM	DESCRIPTION	CONCRETE COVER ABOVE TOP OF METAL DECK (hf) OR (hc) (IN)							
		2.50	3.00	3.50	4.00	4.50	5.00	5.50	6.00
O	MAX. UNSHORED SPAN (C.L.21PSF).FT.	14.06	12.98	12.05	11.25	10.54	9.92	9.37	8.88
P	MAX. UNSHORED SPAN (C.L.42PSF).FT.	10.31	9.96	9.72	9.19	8.71	8.29	7.90	7.55
Q	TOTAL DEAD LOAD (NO CONST.)PSF.	54.01	60.26	66.51	72.76	79.00	85.25	91.50	97.75
R	CONCRETE VOLUME. YD ³ /100FT ²	1.215	1.369	1.524	1.678	1.832	1.986	2.141	2.295

C.L. = CONSTRUCTION LOAD (PSF)

OUTPUT SECTION #2: PLOT DATA - AND INPUT SECTION AS SHOWN #

ITEM	DESCRIPTION	(hf) OR (hc) (IN)	# MAXIMUM SPECIFIED UNIFORMLY DISTRIBUTED LOAD (P.S.F)							
			40	45	50	55	60	65	70	80
1	ALLOW. SINGLE UNSUP. SPAN - FT.	2.50	33.53	32.24	31.13	30.16	29.30	28.53	27.83	26.62
2	ALLOW. SINGLE UNSUP. SPAN - FT.	3.00	35.33	33.97	32.80	31.78	30.87	30.06	29.32	28.05
3	ALLOW. SINGLE UNSUP. SPAN - FT.	3.50	37.13	35.70	34.47	33.39	32.44	31.59	30.82	29.48
4	ALLOW. SINGLE UNSUP. SPAN - FT.	4.00	38.32	37.43	36.14	35.01	34.01	33.12	32.31	30.90
5	ALLOW. SINGLE UNSUP. SPAN - FT.	4.50	38.14	37.47	36.84	36.23	35.59	34.65	33.81	32.34
6	ALLOW. SINGLE UNSUP. SPAN - FT.	5.00	37.98	37.35	36.74	36.17	35.62	35.10	34.60	33.66
7	ALLOW. SINGLE UNSUP. SPAN - FT.	5.50	37.83	37.23	36.66	36.11	35.59	35.09	34.61	33.71
8	ALLOW. SINGLE UNSUP. SPAN - FT.	6.00	37.69	37.13	36.58	36.06	35.57	35.09	34.63	33.76

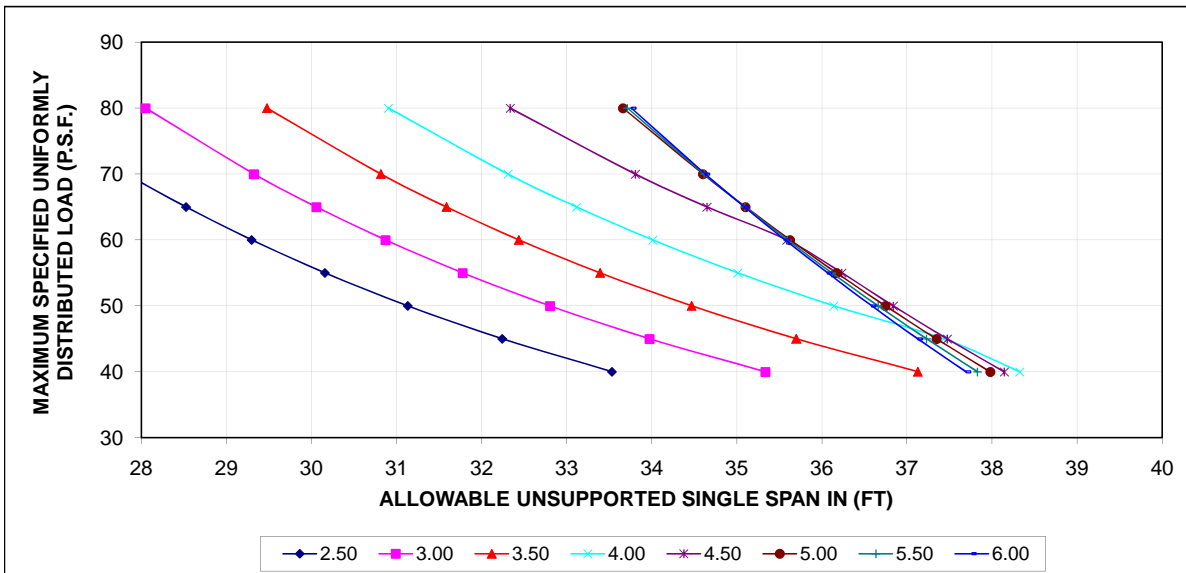



ULTRA-BOND COMPOSITE FLOOR DECK
 MAXIMUM SPECIFIED UNIFORMLY DISTRIBUTED LOAD (P.S.F)
 INCLUDES DEAD AND CONSTRUCTION LOAD CARRIED
 BY METAL DECK *(NOT SHOWN IN TABLES)*
 LIMIT STATE DESIGN (LSD) - **IMPERIAL UNITS**

0.0378" Deck
0.591" Rebar

INPUT SECTION:

ITEM	DESCRIPTION OR SECTION PROPERTIES	CONCRETE COVER ABOVE TOP OF METAL DECK (hf) OR (hc) (IN)							
		2.50	3.00	3.50	4.00	4.50	5.00	5.50	6.00
A	METAL DECK THICK (INCH) (Td)	0.0378	0.0378	0.0378	0.0378	0.0378	0.0378	0.0378	0.0378
B	METAL DECK YIELD STRENGTH (KSI)(Fy)	40.6	40.6	40.6	40.6	40.6	40.6	40.6	40.6
C	METAL DECK EFF. (Ix) (IN ⁴)/FT	3.37	3.37	3.37	3.37	3.37	3.37	3.37	3.37
D	METAL DECK EFF. (Sx) (IN ³)/FT	0.684	0.684	0.684	0.684	0.684	0.684	0.684	0.684
E	METAL DECK (Es)(PSI)	2.95E+07	2.95E+07	2.95E+07	2.95E+07	2.95E+07	2.95E+07	2.95E+07	2.95E+07
F	# REINFORCING STEEL BAR DIA. (INCH)	0.591	0.591	0.591	0.591	0.591	0.591	0.591	0.591
G	CONCRETE STRENGTH (f'c) (PSI)	4350	4350	4350	4350	4350	4350	4350	4350
H	CONCRETE (Ec) (PSI)	3.80E+06	3.80E+06	3.80E+06	3.80E+06	3.80E+06	3.80E+06	3.80E+06	3.80E+06
I	A _F (IN ²)/FT	0.687	0.687	0.687	0.687	0.687	0.687	0.687	0.687
J	I _{X(F)} (IN ⁴)/FT	5.70	5.70	5.70	5.70	5.70	5.70	5.70	5.70
K	ALLOWABLE FORCE (LBS/FT)	437	437	437	437	437	437	437	437
L	FINAL EFF. CROSS SECT. AREA A _{SO} (IN ²)	0.500	0.500	0.500	0.500	0.500	0.500	0.500	0.500
M	DEFLECTION CRITERIA K _{1,2,3,4}	1.000	1.000	1.000	1.000	1.000	1.000	1.000	1.000

* DEFLECTION CRITERIA: L/360 (K₁=1), L/480 (K₂=1.333), L/600 (K₃=1.670) OR L/720 (K₄=2.0)
 # REINFORCING BAR Fy0=58.0KSI

OUTPUT SECTION #1

ITEM	DESCRIPTION	CONCRETE COVER ABOVE TOP OF METAL DECK (hf) OR (hc) (IN)							
		2.50	3.00	3.50	4.00	4.50	5.00	5.50	6.00
O	MAX. UNSHORED SPAN (C.L.21PSF).FT.	9.47	8.73	8.10	7.55	7.07	6.65	6.28	5.95
P	MAX. UNSHORED SPAN (C.L.42PSF).FT.	7.37	6.92	6.51	6.15	5.83	5.54	5.28	5.04
Q	TOTAL DEAD LOAD (NO CONST.).PSF.	52.87	59.11	65.36	71.61	77.86	84.10	90.35	96.60
R	CONCRETE VOLUME. YD ³ /100FT ²	1.236	1.390	1.545	1.699	1.853	2.007	2.162	2.316

C.L. = CONSTRUCTION LOAD (PSF)

OUTPUT SECTION #2: PLOT DATA - AND INPUT SECTION AS SHOWN #

ITEM	DESCRIPTION	(hf) OR (hc) (IN)	# MAXIMUM SPECIFIED UNIFORMLY DISTRIBUTED LOAD (P.S.F)							
			40	45	50	55	60	65	70	80
1	ALLOW. SINGLE UNSUP. SPAN - FT.	2.50	26.86	26.25	25.68	25.14	24.64	24.17	23.72	22.89
2	ALLOW. SINGLE UNSUP. SPAN - FT.	3.00	26.65	26.09	25.55	25.05	24.58	24.13	23.71	22.93
3	ALLOW. SINGLE UNSUP. SPAN - FT.	3.50	26.47	25.94	25.44	24.97	24.53	24.11	23.71	22.96
4	ALLOW. SINGLE UNSUP. SPAN - FT.	4.00	26.30	25.81	25.34	24.90	24.48	24.08	23.70	22.99
5	ALLOW. SINGLE UNSUP. SPAN - FT.	4.50	26.16	25.69	25.25	24.84	24.44	24.06	23.70	23.02
6	ALLOW. SINGLE UNSUP. SPAN - FT.	5.00	26.03	25.59	25.17	24.78	24.40	24.04	23.69	23.04
7	ALLOW. SINGLE UNSUP. SPAN - FT.	5.50	25.91	25.49	25.10	24.72	24.36	24.02	23.69	23.07
8	ALLOW. SINGLE UNSUP. SPAN - FT.	6.00	25.80	25.41	25.03	24.67	24.33	24.00	23.68	23.09

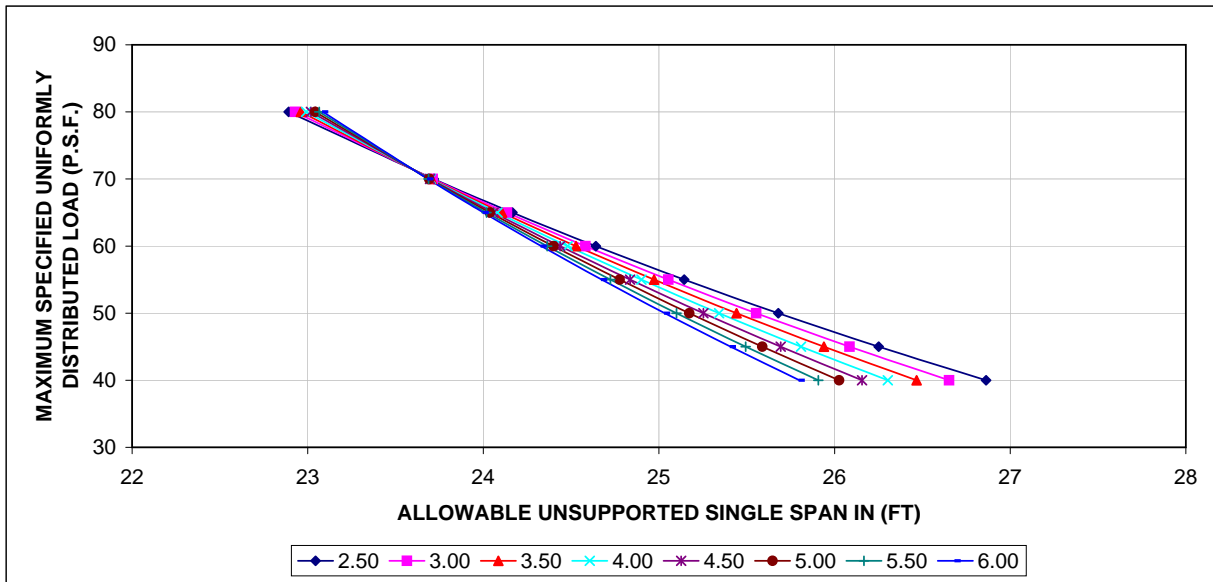



ULTRA-BOND COMPOSITE FLOOR DECK
 MAXIMUM SPECIFIED UNIFORMLY DISTRIBUTED LOAD (P.S.F)
 INCLUDES DEAD AND CONSTRUCTION LOAD CARRIED
 BY METAL DECK *(NOT SHOWN IN TABLES)*
 LIMIT STATE DESIGN (LSD) - **IMPERIAL UNITS**

0.0378" Deck
0.787" Rebar

INPUT SECTION:

ITEM	DESCRIPTION OR SECTION PROPERTIES	CONCRETE COVER ABOVE TOP OF METAL DECK (hf) OR (hc) (IN)							
		2.50	3.00	3.50	4.00	4.50	5.00	5.50	6.00
A	METAL DECK THICK (INCH) (Td)	0.0378	0.0378	0.0378	0.0378	0.0378	0.0378	0.0378	0.0378
B	METAL DECK YIELD STRENGTH (KSI)(Fy)	40.6	40.6	40.6	40.6	40.6	40.6	40.6	40.6
C	METAL DECK EFF. (Ix) (IN ⁴)/FT	3.37	3.37	3.37	3.37	3.37	3.37	3.37	3.37
D	METAL DECK EFF. (Sx) (IN ³)/FT	0.684	0.684	0.684	0.684	0.684	0.684	0.684	0.684
E	METAL DECK (Es)(PSI)	2.95E+07	2.95E+07	2.95E+07	2.95E+07	2.95E+07	2.95E+07	2.95E+07	2.95E+07
F	# REINFORCING STEEL BAR DIA. (INCH)	0.787	0.787	0.787	0.787	0.787	0.787	0.787	0.787
G	CONCRETE STRENGTH (f'c) (PSI)	4350	4350	4350	4350	4350	4350	4350	4350
H	CONCRETE (Ec) (PSI)	3.80E+06	3.80E+06	3.80E+06	3.80E+06	3.80E+06	3.80E+06	3.80E+06	3.80E+06
I	A _F (IN ²)/FT	0.687	0.687	0.687	0.687	0.687	0.687	0.687	0.687
J	I _{X(F)} (IN ⁴)/FT	5.70	5.70	5.70	5.70	5.70	5.70	5.70	5.70
K	ALLOWABLE FORCE (LBS/FT)	437	437	437	437	437	437	437	437
L	FINAL EFF. CROSS SECT. AREA A _{SO} (IN ²)	0.560	0.560	0.560	0.560	0.560	0.560	0.560	0.560
M	DEFLECTION CRITERIA K _{1,2,3,4}	1.000	1.000	1.000	1.000	1.000	1.000	1.000	1.000

* DEFLECTION CRITERIA: L/360 (K₁=1), L/480 (K₂=1.333), L/600 (K₃=1.670) OR L/720 (K₄=2.0)
 # REINFORCING BAR Fy0=58.0KSI

OUTPUT SECTION #1

ITEM	DESCRIPTION	CONCRETE COVER ABOVE TOP OF METAL DECK (hf) OR (hc) (IN)							
		2.50	3.00	3.50	4.00	4.50	5.00	5.50	6.00
O	MAX. UNSHORED SPAN (C.L.21PSF).FT.	9.45	8.71	8.08	7.54	7.06	6.64	6.27	5.94
P	MAX. UNSHORED SPAN (C.L.42PSF).FT.	7.36	6.91	6.50	6.15	5.83	5.54	5.28	5.04
Q	TOTAL DEAD LOAD (NO CONST.).PSF.	53.01	59.25	65.50	71.75	78.00	84.24	90.49	96.74
R	CONCRETE VOLUME. YD ³ /100FT ²	1.231	1.385	1.539	1.693	1.848	2.002	2.156	2.310

C.L. = CONSTRUCTION LOAD (PSF)

OUTPUT SECTION #2: PLOT DATA - AND INPUT SECTION AS SHOWN #

ITEM	DESCRIPTION	(hf) OR (hc) (IN)	# MAXIMUM SPECIFIED UNIFORMLY DISTRIBUTED LOAD (P.S.F)							
			40	45	50	55	60	65	70	80
1	ALLOW. SINGLE UNSUP. SPAN - FT.	2.50	28.37	27.73	27.13	26.56	26.03	25.53	25.06	24.18
2	ALLOW. SINGLE UNSUP. SPAN - FT.	3.00	28.15	27.56	27.00	26.47	25.97	25.50	25.05	24.23
3	ALLOW. SINGLE UNSUP. SPAN - FT.	3.50	27.96	27.40	26.88	26.38	25.92	25.47	25.05	24.26
4	ALLOW. SINGLE UNSUP. SPAN - FT.	4.00	27.79	27.27	26.78	26.31	25.87	25.45	25.04	24.30
5	ALLOW. SINGLE UNSUP. SPAN - FT.	4.50	27.64	27.15	26.69	26.24	25.82	25.42	25.04	24.33
6	ALLOW. SINGLE UNSUP. SPAN - FT.	5.00	27.50	27.04	26.60	26.18	25.78	25.40	25.04	24.35
7	ALLOW. SINGLE UNSUP. SPAN - FT.	5.50	27.38	26.94	26.53	26.13	25.75	25.38	25.04	24.38
8	ALLOW. SINGLE UNSUP. SPAN - FT.	6.00	27.27	26.85	26.46	26.08	25.72	25.37	25.03	24.40

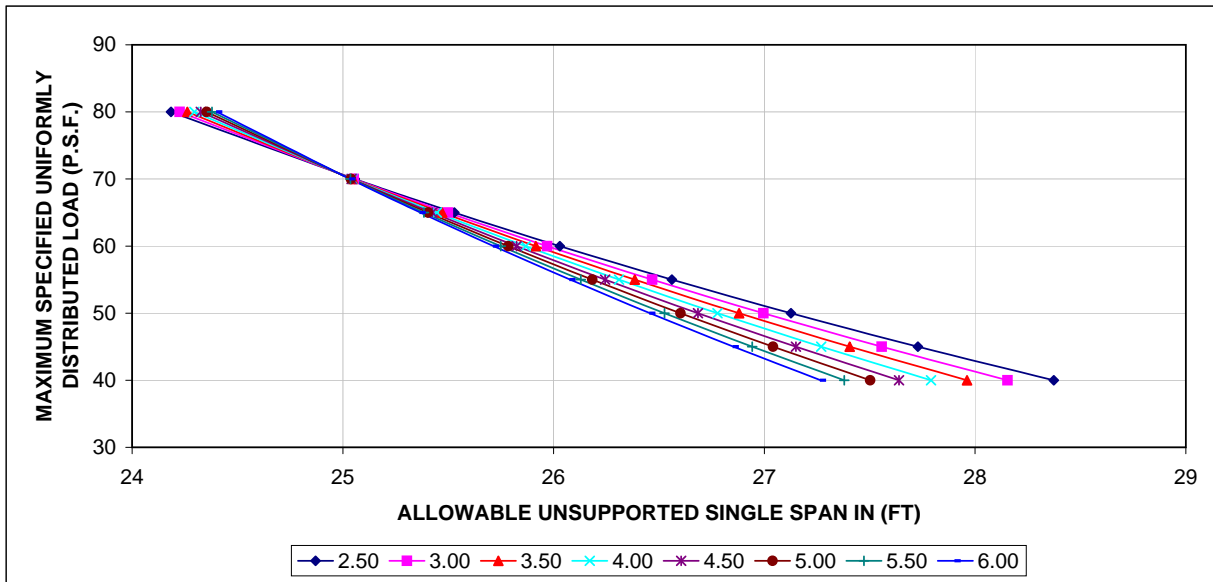



ULTRA-BOND COMPOSITE FLOOR DECK
 MAXIMUM SPECIFIED UNIFORMLY DISTRIBUTED LOAD (P.S.F)
 INCLUDES DEAD AND CONSTRUCTION LOAD CARRIED
 BY METAL DECK *(NOT SHOWN IN TABLES)*
 LIMIT STATE DESIGN (LSD) - IMPERIAL UNITS

0.0378" Deck
0.984" Rebar

INPUT SECTION:

ITEM	DESCRIPTION OR SECTION PROPERTIES	CONCRETE COVER ABOVE TOP OF METAL DECK (hf) OR (hc) (IN)							
		2.50	3.00	3.50	4.00	4.50	5.00	5.50	6.00
A	METAL DECK THICK (INCH) (Td)	0.0378	0.0378	0.0378	0.0378	0.0378	0.0378	0.0378	0.0378
B	METAL DECK YIELD STRENGTH (KSI)(Fy)	40.6	40.6	40.6	40.6	40.6	40.6	40.6	40.6
C	METAL DECK EFF. (Ix) (IN ⁴)/FT	3.37	3.37	3.37	3.37	3.37	3.37	3.37	3.37
D	METAL DECK EFF. (Sx) (IN ³)/FT	0.684	0.684	0.684	0.684	0.684	0.684	0.684	0.684
E	METAL DECK (Es)(PSI)	2.95E+07	2.95E+07	2.95E+07	2.95E+07	2.95E+07	2.95E+07	2.95E+07	2.95E+07
F	# REINFORCING STEEL BAR DIA. (INCH)	0.984	0.984	0.984	0.984	0.984	0.984	0.984	0.984
G	CONCRETE STRENGTH (f'c) (PSI)	4350	4350	4350	4350	4350	4350	4350	4350
H	CONCRETE (Ec) (PSI)	3.80E+06	3.80E+06	3.80E+06	3.80E+06	3.80E+06	3.80E+06	3.80E+06	3.80E+06
I	A _F (IN ²)/FT	0.687	0.687	0.687	0.687	0.687	0.687	0.687	0.687
J	I _{X(F)} (IN ⁴)/FT	5.70	5.70	5.70	5.70	5.70	5.70	5.70	5.70
K	ALLOWABLE FORCE (LBS/FT)	437	437	437	437	437	437	437	437
L	FINAL EFF. CROSS SECT. AREA A _{SO} (IN ²)	0.760	0.760	0.760	0.760	0.760	0.760	0.760	0.760
M	DEFLECTION CRITERIA K _{1,2,3,4}	1.000	1.000	1.000	1.000	1.000	1.000	1.000	1.000

* DEFLECTION CRITERIA: L/360 (K₁=1), L/480 (K₂=1.333), L/600 (K₃=1.670) OR L/720 (K₄=2.0)
 # REINFORCING BAR Fy0=58.0KSI

OUTPUT SECTION #1

ITEM	DESCRIPTION	CONCRETE COVER ABOVE TOP OF METAL DECK (hf) OR (hc) (IN)							
		2.50	3.00	3.50	4.00	4.50	5.00	5.50	6.00
O	MAX. UNSHORED SPAN (C.L.21PSF).FT.	9.42	8.69	8.07	7.52	7.05	6.63	6.26	5.93
P	MAX. UNSHORED SPAN (C.L.42PSF).FT.	7.35	6.89	6.49	6.14	5.82	5.53	5.27	5.03
Q	TOTAL DEAD LOAD (NO CONST.).PSF.	53.19	59.43	65.68	71.93	78.18	84.42	90.67	96.92
R	CONCRETE VOLUME. YD ³ /100FT ²	1.224	1.378	1.532	1.686	1.841	1.995	2.149	2.303

C.L. = CONSTRUCTION LOAD (PSF)

OUTPUT SECTION #2: PLOT DATA - AND INPUT SECTION AS SHOWN #

ITEM	DESCRIPTION	(hf) OR (hc) (IN)	# MAXIMUM SPECIFIED UNIFORMLY DISTRIBUTED LOAD (P.S.F)							
			40	45	50	55	60	65	70	80
1	ALLOW. SINGLE UNSUP. SPAN - FT.	2.50	32.90	32.15	31.45	30.80	30.18	29.60	29.06	28.05
2	ALLOW. SINGLE UNSUP. SPAN - FT.	3.00	32.65	31.96	31.31	30.70	30.12	29.58	29.06	28.10
3	ALLOW. SINGLE UNSUP. SPAN - FT.	3.50	32.44	31.79	31.18	30.61	30.07	29.55	29.06	28.15
4	ALLOW. SINGLE UNSUP. SPAN - FT.	4.00	32.24	31.64	31.07	30.53	30.02	29.53	29.06	28.19
5	ALLOW. SINGLE UNSUP. SPAN - FT.	4.50	32.07	31.51	30.97	30.46	29.97	29.51	29.06	28.23
6	ALLOW. SINGLE UNSUP. SPAN - FT.	5.00	31.92	31.39	30.88	30.39	29.93	29.49	29.07	28.27
7	ALLOW. SINGLE UNSUP. SPAN - FT.	5.50	31.78	31.28	30.80	30.33	29.89	29.47	29.07	28.31
8	ALLOW. SINGLE UNSUP. SPAN - FT.	6.00	31.66	31.18	30.72	30.28	29.86	29.46	29.07	28.34

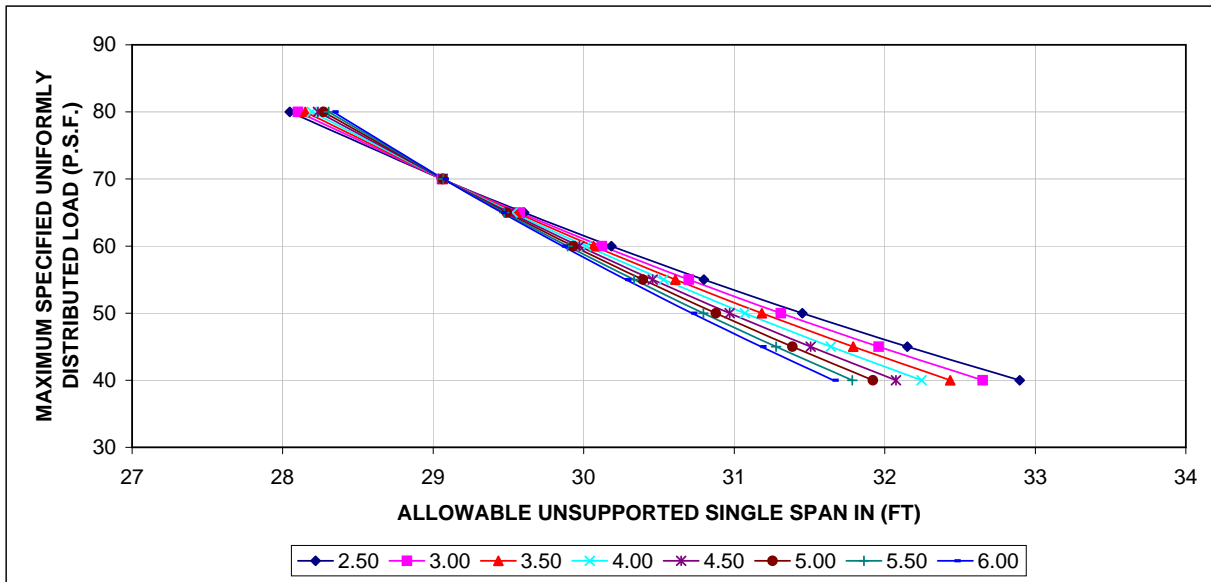



ULTRA-BOND COMPOSITE FLOOR DECK
 MAXIMUM SPECIFIED UNIFORMLY DISTRIBUTED LOAD (P.S.F)
 INCLUDES DEAD AND CONSTRUCTION LOAD CARRIED
 BY METAL DECK *(NOT SHOWN IN TABLES)*
 LIMIT STATE DESIGN (LSD) - IMPERIAL UNITS

0.0378" Deck
1.181" Rebar

INPUT SECTION:

ITEM	DESCRIPTION OR SECTION PROPERTIES	CONCRETE COVER ABOVE TOP OF METAL DECK (hf) OR (hc) (IN)							
		2.50	3.00	3.50	4.00	4.50	5.00	5.50	6.00
A	METAL DECK THICK (INCH) (Td)	0.0378	0.0378	0.0378	0.0378	0.0378	0.0378	0.0378	0.0378
B	METAL DECK YIELD STRENGTH (KSI)(Fy)	40.6	40.6	40.6	40.6	40.6	40.6	40.6	40.6
C	METAL DECK EFF. (Ix) (IN ⁴)/FT	3.37	3.37	3.37	3.37	3.37	3.37	3.37	3.37
D	METAL DECK EFF. (Sx) (IN ³)/FT	0.684	0.684	0.684	0.684	0.684	0.684	0.684	0.684
E	METAL DECK (Es)(PSI)	2.95E+07	2.95E+07	2.95E+07	2.95E+07	2.95E+07	2.95E+07	2.95E+07	2.95E+07
F	# REINFORCING STEEL BAR DIA. (INCH)	1.181	1.181	1.181	1.181	1.181	1.181	1.181	1.181
G	CONCRETE STRENGTH (f'c) (PSI)	4350	4350	4350	4350	4350	4350	4350	4350
H	CONCRETE (Ec) (PSI)	3.80E+06	3.80E+06	3.80E+06	3.80E+06	3.80E+06	3.80E+06	3.80E+06	3.80E+06
I	A _F (IN ²)/FT	0.687	0.687	0.687	0.687	0.687	0.687	0.687	0.687
J	I _{X(F)} (IN ⁴)/FT	5.70	5.70	5.70	5.70	5.70	5.70	5.70	5.70
K	ALLOWABLE FORCE (LBS/FT)	437	437	437	437	437	437	437	437
L	FINAL EFF. CROSS SECT. AREA A _{SO} (IN ²)	1.095	1.095	1.095	1.095	1.095	1.095	1.095	1.095
M	DEFLECTION CRITERIA K _{1,2,3,4}	1.000	1.000	1.000	1.000	1.000	1.000	1.000	1.000

* DEFLECTION CRITERIA: L/360 (K₁=1), L/480 (K₂=1.333), L/600 (K₃=1.670) OR L/720 (K₄=2.0)
 # REINFORCING BAR Fy0=58.0KSI

OUTPUT SECTION #1

ITEM	DESCRIPTION	CONCRETE COVER ABOVE TOP OF METAL DECK (hf) OR (hc) (IN)							
		2.50	3.00	3.50	4.00	4.50	5.00	5.50	6.00
O	MAX. UNSHORED SPAN (C.L.21PSF).FT.	9.40	8.67	8.05	7.51	7.03	6.62	6.25	5.92
P	MAX. UNSHORED SPAN (C.L.42PSF).FT.	7.33	6.88	6.48	6.13	5.81	5.52	5.26	5.03
Q	TOTAL DEAD LOAD (NO CONST.).PSF.	53.41	59.66	65.90	72.15	78.40	84.65	90.89	97.14
R	CONCRETE VOLUME. YD ³ /100FT ²	1.215	1.369	1.524	1.678	1.832	1.986	2.141	2.295

C.L. = CONSTRUCTION LOAD (PSF)

OUTPUT SECTION #2: PLOT DATA - AND INPUT SECTION AS SHOWN #

ITEM	DESCRIPTION	(hf) OR (hc) (IN)	# MAXIMUM SPECIFIED UNIFORMLY DISTRIBUTED LOAD (P.S.F)							
			40	45	50	55	60	65	70	80
			1	ALLOW. SINGLE UNSUP. SPAN - FT.	2.50	36.32	34.92	33.72	32.67	31.73
2	ALLOW. SINGLE UNSUP. SPAN - FT.	3.00	38.30	36.83	35.56	34.45	33.46	32.58	31.79	30.41
3	ALLOW. SINGLE UNSUP. SPAN - FT.	3.50	38.67	37.90	37.18	36.22	35.18	34.26	33.42	31.97
4	ALLOW. SINGLE UNSUP. SPAN - FT.	4.00	38.45	37.74	37.06	36.41	35.80	35.22	34.67	33.53
5	ALLOW. SINGLE UNSUP. SPAN - FT.	4.50	38.26	37.59	36.95	36.34	35.76	35.21	34.68	33.69
6	ALLOW. SINGLE UNSUP. SPAN - FT.	5.00	38.09	37.46	36.85	36.27	35.72	35.19	34.69	33.74
7	ALLOW. SINGLE UNSUP. SPAN - FT.	5.50	37.94	37.34	36.76	36.21	35.69	35.18	34.70	33.79
8	ALLOW. SINGLE UNSUP. SPAN - FT.	6.00	37.80	37.23	36.68	36.16	35.65	35.17	34.71	33.84

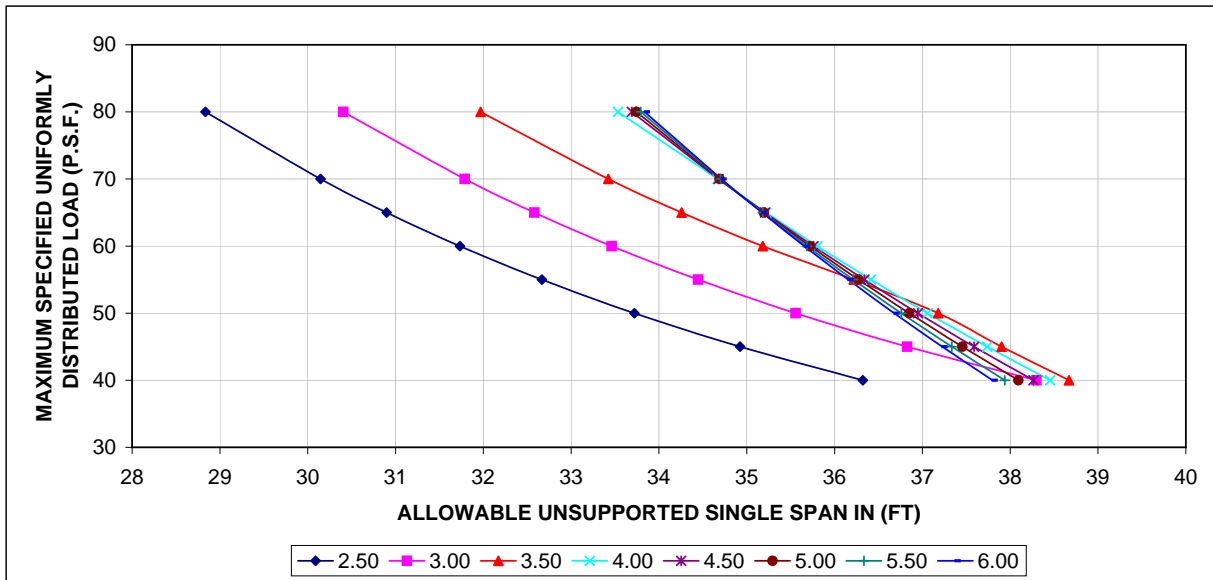



ULTRA-BOND COMPOSITE FLOOR DECK
 MAXIMUM SPECIFIED UNIFORMLY DISTRIBUTED LOAD (KPa)
 INCLUDES DEAD AND CONSTRUCTION LOAD CARRIED
 BY METAL DECK *(NOT SHOWN IN TABLES)*
 LIMIT STATE DESIGN (LSD) -METRIC UNITS

1.21 mm Deck
10 mm Rebar

INPUT SECTION:

ITEM	DESCRIPTION OR SECTION PROPERTIES	CONCRETE COVER ABOVE TOP OF METAL DECK (hf) OR (hc) (mm)							
		63.50	76.20	88.90	101.60	114.30	127.00	139.70	152.40
A	METAL DECK THICK (mm) (Td)	1.21	1.21	1.21	1.21	1.21	1.21	1.21	1.21
B	METAL DECK YIELD STRENGTH (KPa)(Fy)	280	280	280	280	280	280	280	280
C	METAL DECK EFF. (Ix) (mm ⁴)/m	6.95E+06	6.95E+06	6.95E+06	6.95E+06	6.95E+06	6.95E+06	6.95E+06	6.95E+06
D	METAL DECK EFF. (Sx) (mm ³)/m	6.18E+04	6.18E+04	6.18E+04	6.18E+04	6.18E+04	6.18E+04	6.18E+04	6.18E+04
E	METAL DECK (Es)(KPa)	2.03E+08	2.03E+08	2.03E+08	2.03E+08	2.03E+08	2.03E+08	2.03E+08	2.03E+08
F	# REINFORCING STEEL BAR DIA. (mm)	10	10	10	10	10	10	10	10
G	CONCRETE STRENGTH (f'c) (KPa)	3.00E+04	3.00E+04	3.00E+04	3.00E+04	3.00E+04	3.00E+04	3.00E+04	3.00E+04
H	CONCRETE (Ec) (KPa)	2.62E+07	2.62E+07	2.62E+07	2.62E+07	2.62E+07	2.62E+07	2.62E+07	2.62E+07
I	A _F (mm ²)/m	1830.917	1830.917	1830.917	1830.917	1830.917	1830.917	1830.917	1830.917
J	I _{x(f)} (mm ⁴)/m	9.80E+06	9.80E+06	9.80E+06	9.80E+06	9.80E+06	9.80E+06	9.80E+06	9.80E+06
K	ALLOWABLE FORCE (KN/m)	9.617	9.617	9.617	9.617	9.617	9.617	9.617	9.617
L	FINAL EFF. CROSS SECT. AREA A _{SO} (IN ²)	301	301	301	301	301	301	301	301
M	DEFLECTION CRITERIA K _{1,2,3,4}	1.333	1.333	1.333	1.333	1.333	1.333	1.333	1.333
N	DEFLECTION CRITERIA *	L/480	L/480	L/480	L/480	L/480	L/480	L/480	L/480

* DEFLECTION CRITERIA: L/360 (K₁=1), L/480 (K₂=1.333), L/600 (K₃=1.670) OR L/720 (K₄=2.0)
 # REINFORCING BAR Fy0=400MPa

OUTPUT SECTION #1

ITEM	DESCRIPTION	CONCRETE COVER ABOVE TOP OF METAL DECK (hf) OR (hc) (mm)							
		63.50	76.20	88.90	101.60	114.30	127.00	139.70	152.40
O	MAX. UNSHORED SPAN (C.L.1.006KPa).m.	4.32	3.99	3.70	3.45	3.23	3.04	2.87	2.72
P	MAX. UNSHORED SPAN (C.L.2.011KPa).m.	3.16	3.01	2.98	2.82	2.67	2.54	2.42	2.31
Q	TOTAL DEAD LOAD (NO CONST.)KPa.	2.555	2.855	3.154	3.453	3.752	4.051	4.350	4.649
R	CONCRETE VOLUME. m ³ /10m ²	1.021	1.147	1.274	1.401	1.528	1.655	1.782	1.909

C.L. = CONSTRUCTION LOAD (Pa)

OUTPUT SECTION #2: PLOT DATA - AND INPUT SECTION AS SHOWN #

ITEM	DESCRIPTION	(hf) OR (hc) (mm)	# MAXIMUM SPECIFIED UNIFORMLY DISTRIBUTED LOAD (KPa)							
			1.92	2.15	2.39	2.63	2.87	3.11	3.35	3.83
1	ALLOW. SINGLE UNSUP. SPAN - m.	63.50	7.89	7.71	7.54	7.39	7.24	7.10	6.97	6.73
2	ALLOW. SINGLE UNSUP. SPAN - m.	76.20	7.83	7.66	7.51	7.36	7.22	7.09	6.97	6.74
3	ALLOW. SINGLE UNSUP. SPAN - m.	88.90	7.78	7.62	7.48	7.34	7.21	7.09	6.97	6.75
4	ALLOW. SINGLE UNSUP. SPAN - m.	101.60	7.73	7.59	7.45	7.32	7.20	7.08	6.97	6.76
5	ALLOW. SINGLE UNSUP. SPAN - m.	114.30	7.69	7.55	7.42	7.30	7.18	7.07	6.97	6.77
6	ALLOW. SINGLE UNSUP. SPAN - m.	127.00	7.65	7.52	7.40	7.28	7.17	7.07	6.97	6.78
7	ALLOW. SINGLE UNSUP. SPAN - m.	139.70	7.62	7.50	7.38	7.27	7.16	7.06	6.97	6.78
8	ALLOW. SINGLE UNSUP. SPAN - m.	152.40	7.59	7.47	7.36	7.26	7.15	7.06	6.97	6.79

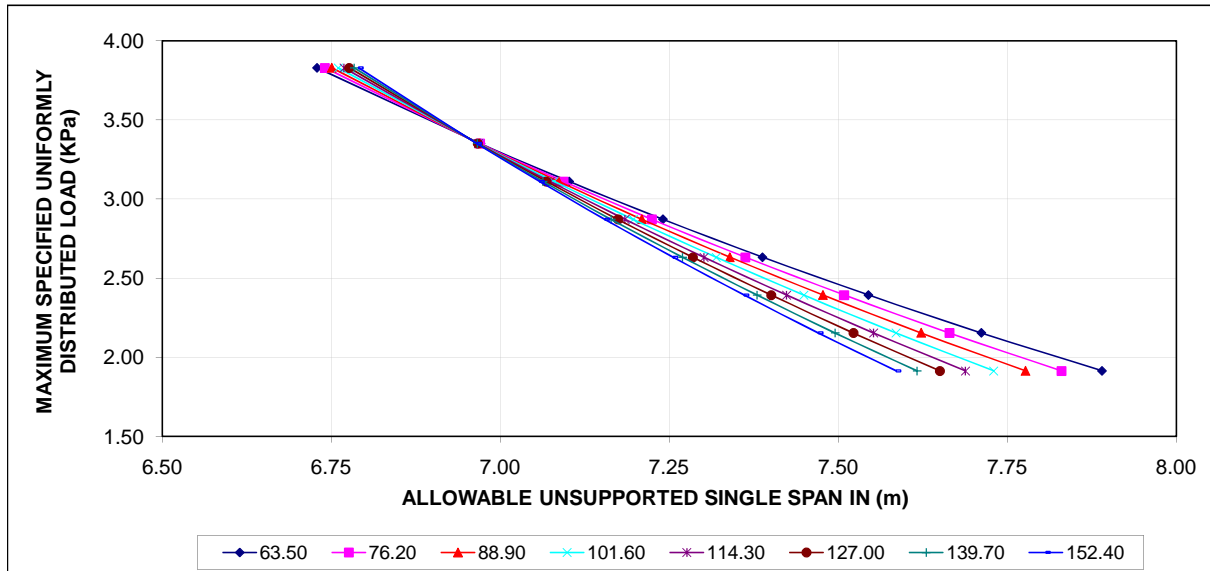



ULTRA-BOND COMPOSITE FLOOR DECK
 MAXIMUM SPECIFIED UNIFORMLY DISTRIBUTED LOAD (KPa)
 INCLUDES DEAD AND CONSTRUCTION LOAD CARRIED
 BY METAL DECK *(NOT SHOWN IN TABLES)*
 LIMIT STATE DESIGN (LSD) -METRIC UNITS

1.21 mm Deck
15 mm Rebar

INPUT SECTION:

ITEM	DESCRIPTION OR SECTION PROPERTIES	CONCRETE COVER ABOVE TOP OF METAL DECK (hf) OR (hc) (mm)							
		63.50	76.20	88.90	101.60	114.30	127.00	139.70	152.40
A	METAL DECK THICK (mm) (Td)	1.21	1.21	1.21	1.21	1.21	1.21	1.21	1.21
B	METAL DECK YIELD STRENGTH (KPa)(Fy)	280	280	280	280	280	280	280	280
C	METAL DECK EFF. (Ix) (mm ⁴)/m	6.95E+06	6.95E+06	6.95E+06	6.95E+06	6.95E+06	6.95E+06	6.95E+06	6.95E+06
D	METAL DECK EFF. (Sx) (mm ³)/m	6.18E+04	6.18E+04	6.18E+04	6.18E+04	6.18E+04	6.18E+04	6.18E+04	6.18E+04
E	METAL DECK (Es)(KPa)	2.03E+08	2.03E+08	2.03E+08	2.03E+08	2.03E+08	2.03E+08	2.03E+08	2.03E+08
F	# REINFORCING STEEL BAR DIA. (mm)	15	15	15	15	15	15	15	15
G	CONCRETE STRENGTH (f'c) (KPa)	3.00E+04	3.00E+04	3.00E+04	3.00E+04	3.00E+04	3.00E+04	3.00E+04	3.00E+04
H	CONCRETE (Ec) (KPa)	2.62E+07	2.62E+07	2.62E+07	2.62E+07	2.62E+07	2.62E+07	2.62E+07	2.62E+07
I	A _F (mm ²)/m	1830.917	1830.917	1830.917	1830.917	1830.917	1830.917	1830.917	1830.917
J	I _{x(F)} (mm ⁴)/m	9.80E+06	9.80E+06	9.80E+06	9.80E+06	9.80E+06	9.80E+06	9.80E+06	9.80E+06
K	ALLOWABLE FORCE (KN/m)	9.617	9.617	9.617	9.617	9.617	9.617	9.617	9.617
L	FINAL EFF. CROSS SECT. AREA A _{EO} (IN ²)	387	387	387	387	387	387	387	387
M	DEFLECTION CRITERIA K _{1,2,3,4}	1.333	1.333	1.333	1.333	1.333	1.333	1.333	1.333
N	DEFLECTION CRITERIA *	L/480	L/480	L/480	L/480	L/480	L/480	L/480	L/480

* DEFLECTION CRITERIA: L/360 (K₁=1), L/480 (K₂=1.333), L/600 (K₃=1.670) OR L/720 (K₄=2.0)
 # REINFORCING BAR Fy0=400MPa

OUTPUT SECTION #1

ITEM	DESCRIPTION	CONCRETE COVER ABOVE TOP OF METAL DECK (hf) OR (hc) (mm)							
		63.50	76.20	88.90	101.60	114.30	127.00	139.70	152.40
O	MAX. UNSHORED SPAN (C.L. 1.006KPa).m.	4.32	3.98	3.70	3.45	3.23	3.04	2.87	2.72
P	MAX. UNSHORED SPAN (C.L. 2.011KPa).m.	3.16	3.01	2.98	2.81	2.67	2.54	2.42	2.31
Q	TOTAL DEAD LOAD (NO CONST.)KPa.	2.560	2.859	3.158	3.458	3.757	4.056	4.355	4.654
R	CONCRETE VOLUME. m ³ /10m ²	1.017	1.144	1.271	1.398	1.525	1.652	1.779	1.906

C.L. = CONSTRUCTION LOAD (Pa)

OUTPUT SECTION #2: PLOT DATA - AND INPUT SECTION AS SHOWN #

ITEM	DESCRIPTION	(hf) OR (hc) (mm)	# MAXIMUM SPECIFIED UNIFORMLY DISTRIBUTED LOAD (KPa)							
			1.92	2.15	2.39	2.63	2.87	3.11	3.35	3.83
1	ALLOW. SINGLE UNSUP. SPAN - m.	63.50	8.92	8.71	8.53	8.35	8.18	8.03	7.88	7.61
2	ALLOW. SINGLE UNSUP. SPAN - m.	76.20	8.85	8.66	8.49	8.32	8.17	8.02	7.88	7.62
3	ALLOW. SINGLE UNSUP. SPAN - m.	88.90	8.79	8.62	8.45	8.30	8.15	8.01	7.88	7.63
4	ALLOW. SINGLE UNSUP. SPAN - m.	101.60	8.74	8.58	8.42	8.28	8.14	8.00	7.88	7.64
5	ALLOW. SINGLE UNSUP. SPAN - m.	114.30	8.69	8.54	8.39	8.26	8.12	8.00	7.88	7.65
6	ALLOW. SINGLE UNSUP. SPAN - m.	127.00	8.65	8.51	8.37	8.24	8.11	7.99	7.88	7.66
7	ALLOW. SINGLE UNSUP. SPAN - m.	139.70	8.61	8.48	8.35	8.22	8.10	7.99	7.88	7.67
8	ALLOW. SINGLE UNSUP. SPAN - m.	152.40	8.58	8.45	8.33	8.21	8.09	7.98	7.88	7.68

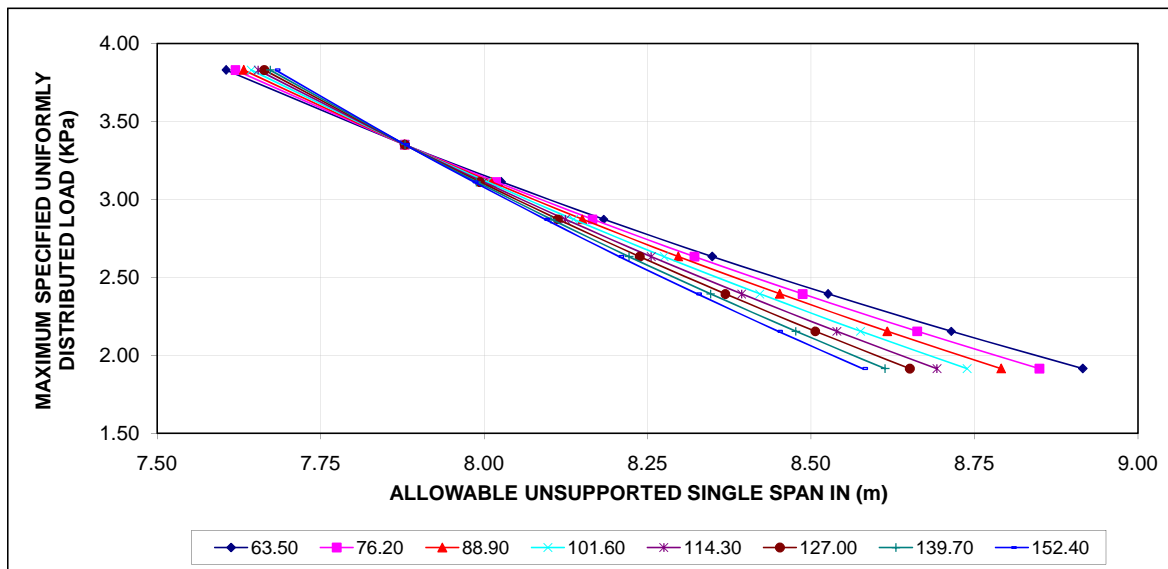



ULTRA-BOND COMPOSITE FLOOR DECK
 MAXIMUM SPECIFIED UNIFORMLY DISTRIBUTED LOAD (KPa)
 INCLUDES DEAD AND CONSTRUCTION LOAD CARRIED
 BY METAL DECK *(NOT SHOWN IN TABLES)*
 LIMIT STATE DESIGN (LSD) -METRIC UNITS

1.21 mm Deck
20 mm Rebar

INPUT SECTION:

ITEM	DESCRIPTION OR SECTION PROPERTIES	CONCRETE COVER ABOVE TOP OF METAL DECK (hf) OR (hc) (mm)							
		63.50	76.20	88.90	101.60	114.30	127.00	139.70	152.40
A	METAL DECK THICK (mm) (Td)	1.21	1.21	1.21	1.21	1.21	1.21	1.21	1.21
B	METAL DECK YIELD STRENGTH (KPa)(Fy)	280	280	280	280	280	280	280	280
C	METAL DECK EFF. (Ix) (mm ⁴)/m	6.95E+06	6.95E+06	6.95E+06	6.95E+06	6.95E+06	6.95E+06	6.95E+06	6.95E+06
D	METAL DECK EFF. (Sx) (mm ³)/m	6.18E+04	6.18E+04	6.18E+04	6.18E+04	6.18E+04	6.18E+04	6.18E+04	6.18E+04
E	METAL DECK (Es)(KPa)	2.03E+08	2.03E+08	2.03E+08	2.03E+08	2.03E+08	2.03E+08	2.03E+08	2.03E+08
F	# REINFORCING STEEL BAR DIA. (mm)	20	20	20	20	20	20	20	20
G	CONCRETE STRENGTH (f'c) (KPa)	3.00E+04	3.00E+04	3.00E+04	3.00E+04	3.00E+04	3.00E+04	3.00E+04	3.00E+04
H	CONCRETE (Ec) (KPa)	2.62E+07	2.62E+07	2.62E+07	2.62E+07	2.62E+07	2.62E+07	2.62E+07	2.62E+07
I	A _F (mm ²)/m	1830.917	1830.917	1830.917	1830.917	1830.917	1830.917	1830.917	1830.917
J	I _{x(f)} (mm ⁴)/m	9.80E+06	9.80E+06	9.80E+06	9.80E+06	9.80E+06	9.80E+06	9.80E+06	9.80E+06
K	ALLOWABLE FORCE (KN/m)	9.617	9.617	9.617	9.617	9.617	9.617	9.617	9.617
L	FINAL EFF. CROSS SECT. AREA A _{SO} (IN ²)	434	434	434	434	434	434	434	434
M	DEFLECTION CRITERIA K _{1,2,3,4}	1.333	1.333	1.333	1.333	1.333	1.333	1.333	1.333
N	DEFLECTION CRITERIA *	L/480	L/480	L/480	L/480	L/480	L/480	L/480	L/480

* DEFLECTION CRITERIA: L/360 (K₁=1), L/480 (K₂=1.333), L/600 (K₃=1.670) OR L/720 (K₄=2.0)
 # REINFORCING BAR Fy0=400MPa

OUTPUT SECTION #1

ITEM	DESCRIPTION	CONCRETE COVER ABOVE TOP OF METAL DECK (hf) OR (hc) (mm)							
		63.50	76.20	88.90	101.60	114.30	127.00	139.70	152.40
O	MAX. UNSHORED SPAN (C.L.1.006KPa).m.	4.31	3.97	3.69	3.44	3.23	3.04	2.87	2.72
P	MAX. UNSHORED SPAN (C.L.2.011KPa).m.	3.16	3.02	2.97	2.81	2.66	2.53	2.41	2.31
Q	TOTAL DEAD LOAD (NO CONST.).KPa.	2.567	2.866	3.165	3.464	3.763	4.063	4.362	4.661
R	CONCRETE VOLUME. m ³ /10m ²	1.013	1.140	1.267	1.394	1.521	1.648	1.775	1.901

C.L. = CONSTRUCTION LOAD (Pa)

OUTPUT SECTION #2: PLOT DATA - AND INPUT SECTION AS SHOWN #

ITEM	DESCRIPTION	(hf) OR (hc) (mm)	# MAXIMUM SPECIFIED UNIFORMLY DISTRIBUTED LOAD (KPa)							
			1.92	2.15	2.39	2.63	2.87	3.11	3.35	3.83
1	ALLOW. SINGLE UNSUP. SPAN - m.	63.50	9.42	9.20	9.00	8.82	8.64	8.48	8.32	7.97
2	ALLOW. SINGLE UNSUP. SPAN - m.	76.20	9.35	9.15	8.96	8.79	8.62	8.47	8.32	8.05
3	ALLOW. SINGLE UNSUP. SPAN - m.	88.90	9.29	9.10	8.93	8.76	8.61	8.46	8.32	8.06
4	ALLOW. SINGLE UNSUP. SPAN - m.	101.60	9.23	9.06	8.90	8.74	8.60	8.46	8.32	8.08
5	ALLOW. SINGLE UNSUP. SPAN - m.	114.30	9.18	9.02	8.87	8.72	8.58	8.45	8.32	8.09
6	ALLOW. SINGLE UNSUP. SPAN - m.	127.00	9.14	8.99	8.84	8.70	8.57	8.45	8.33	8.10
7	ALLOW. SINGLE UNSUP. SPAN - m.	139.70	9.10	8.96	8.82	8.69	8.56	8.44	8.33	8.11
8	ALLOW. SINGLE UNSUP. SPAN - m.	152.40	9.07	8.93	8.80	8.67	8.55	8.44	8.33	8.12

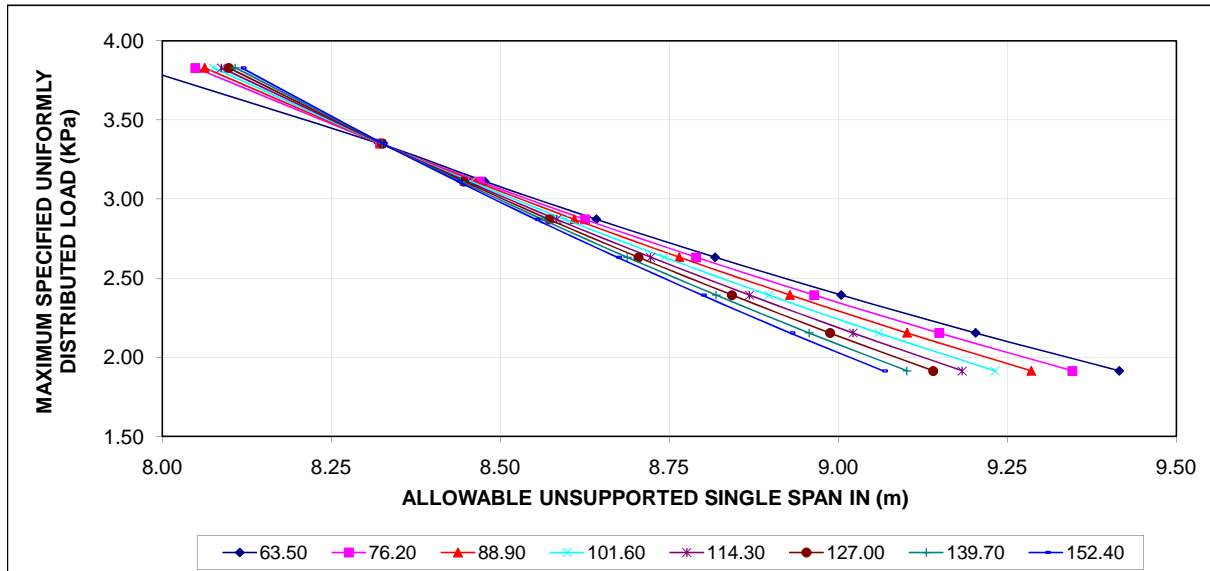



ULTRA-BOND COMPOSITE FLOOR DECK
 MAXIMUM SPECIFIED UNIFORMLY DISTRIBUTED LOAD (KPa)
 INCLUDES DEAD AND CONSTRUCTION LOAD CARRIED
 BY METAL DECK *(NOT SHOWN IN TABLES)*
 LIMIT STATE DESIGN (LSD) -METRIC UNITS

1.21 mm Deck
25 mm Rebar

INPUT SECTION:

ITEM	DESCRIPTION OR SECTION PROPERTIES	CONCRETE COVER ABOVE TOP OF METAL DECK (hf) OR (hc) (mm)							
		63.50	76.20	88.90	101.60	114.30	127.00	139.70	152.40
A	METAL DECK THICK (mm) (Td)	1.21	1.21	1.21	1.21	1.21	1.21	1.21	1.21
B	METAL DECK YIELD STRENGTH (KPa)(Fy)	280	280	280	280	280	280	280	280
C	METAL DECK EFF. (Ix) (mm ⁴)/m	6.95E+06	6.95E+06	6.95E+06	6.95E+06	6.95E+06	6.95E+06	6.95E+06	6.95E+06
D	METAL DECK EFF. (Sx) (mm ³)/m	6.18E+04	6.18E+04	6.18E+04	6.18E+04	6.18E+04	6.18E+04	6.18E+04	6.18E+04
E	METAL DECK (Es)(KPa)	2.03E+08	2.03E+08	2.03E+08	2.03E+08	2.03E+08	2.03E+08	2.03E+08	2.03E+08
F	# REINFORCING STEEL BAR DIA. (mm)	25	25	25	25	25	25	25	25
G	CONCRETE STRENGTH (f'c) (KPa)	3.00E+04	3.00E+04	3.00E+04	3.00E+04	3.00E+04	3.00E+04	3.00E+04	3.00E+04
H	CONCRETE (Ec) (KPa)	2.62E+07	2.62E+07	2.62E+07	2.62E+07	2.62E+07	2.62E+07	2.62E+07	2.62E+07
I	A _F (mm ²)/m	1830.917	1830.917	1830.917	1830.917	1830.917	1830.917	1830.917	1830.917
J	I _{x(f)} (mm ⁴)/m	9.80E+06	9.80E+06	9.80E+06	9.80E+06	9.80E+06	9.80E+06	9.80E+06	9.80E+06
K	ALLOWABLE FORCE (KN/m)	9.617	9.617	9.617	9.617	9.617	9.617	9.617	9.617
L	FINAL EFF. CROSS SECT. AREA A _{SO} (IN ²)	581	581	581	581	581	581	581	581
M	DEFLECTION CRITERIA K _{1,2,3,4}	1.333	1.333	1.333	1.333	1.333	1.333	1.333	1.333
N	DEFLECTION CRITERIA *	L/480	L/480	L/480	L/480	L/480	L/480	L/480	L/480

* DEFLECTION CRITERIA: L/360 (K₁=1), L/480 (K₂=1.333), L/600 (K₃=1.670) OR L/720 (K₄=2.0)
 # REINFORCING BAR Fy0=400MPa

OUTPUT SECTION #1

ITEM	DESCRIPTION	CONCRETE COVER ABOVE TOP OF METAL DECK (hf) OR (hc) (mm)							
		63.50	76.20	88.90	101.60	114.30	127.00	139.70	152.40
O	MAX. UNSHORED SPAN (C.L.1.006KPa).m.	4.30	3.97	3.68	3.44	3.22	3.03	2.86	2.71
P	MAX. UNSHORED SPAN (C.L.2.011KPa).m.	3.15	3.03	2.97	2.81	2.66	2.53	2.41	2.30
Q	TOTAL DEAD LOAD (NO CONST.)KPa.	2.576	2.875	3.174	3.473	3.772	4.071	4.370	4.670
R	CONCRETE VOLUME. m ³ /10m ²	1.007	1.134	1.261	1.388	1.515	1.642	1.769	1.896

C.L. = CONSTRUCTION LOAD (Pa)

OUTPUT SECTION #2: PLOT DATA - AND INPUT SECTION AS SHOWN #

ITEM	DESCRIPTION	(hf) OR (hc) (mm)	# MAXIMUM SPECIFIED UNIFORMLY DISTRIBUTED LOAD (KPa)							
			1.92	2.15	2.39	2.63	2.87	3.11	3.35	3.83
1	ALLOW. SINGLE UNSUP. SPAN - m.	63.50	10.12	9.73	9.40	9.10	8.84	8.61	8.40	8.04
2	ALLOW. SINGLE UNSUP. SPAN - m.	76.20	10.65	10.24	9.89	9.58	9.30	9.06	8.84	8.45
3	ALLOW. SINGLE UNSUP. SPAN - m.	88.90	10.69	10.48	10.28	10.05	9.76	9.51	9.28	8.87
4	ALLOW. SINGLE UNSUP. SPAN - m.	101.60	10.63	10.44	10.25	10.07	9.90	9.74	9.59	9.29
5	ALLOW. SINGLE UNSUP. SPAN - m.	114.30	10.58	10.40	10.22	10.05	9.89	9.74	9.59	9.32
6	ALLOW. SINGLE UNSUP. SPAN - m.	127.00	10.53	10.36	10.19	10.03	9.88	9.74	9.60	9.34
7	ALLOW. SINGLE UNSUP. SPAN - m.	139.70	10.49	10.33	10.17	10.02	9.87	9.73	9.60	9.35
8	ALLOW. SINGLE UNSUP. SPAN - m.	152.40	10.45	10.29	10.14	10.00	9.86	9.73	9.60	9.36

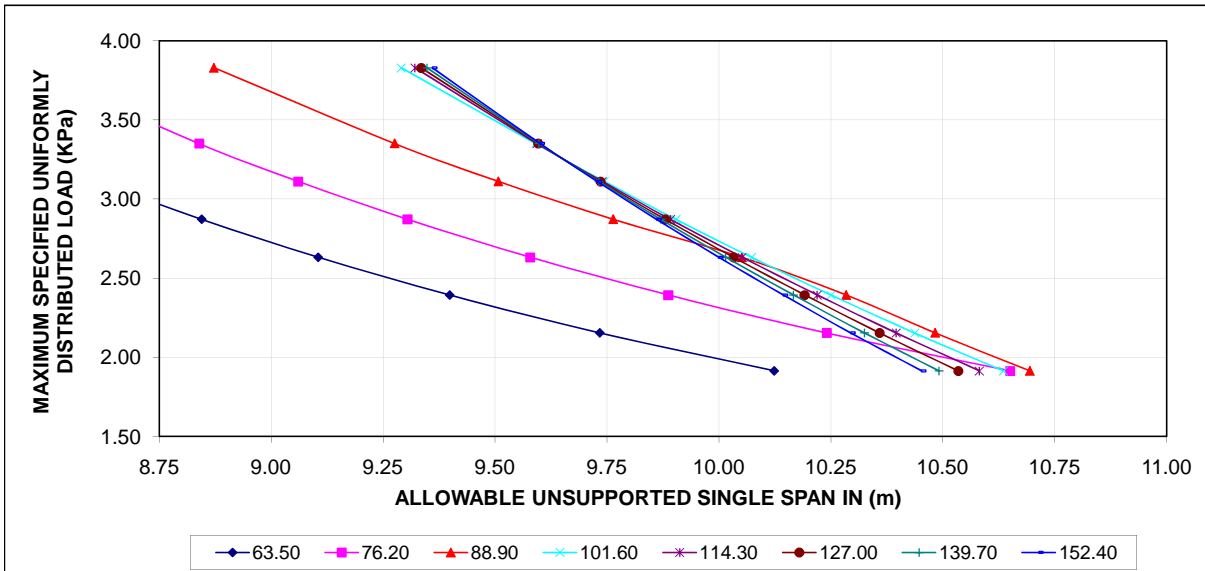



ULTRA-BOND COMPOSITE FLOOR DECK
 MAXIMUM SPECIFIED UNIFORMLY DISTRIBUTED LOAD (KPa)
 INCLUDES DEAD AND CONSTRUCTION LOAD CARRIED
 BY METAL DECK *(NOT SHOWN IN TABLES)*
 LIMIT STATE DESIGN (LSD) -METRIC UNITS

1.21 mm Deck
30 mm Rebar

INPUT SECTION:

ITEM	DESCRIPTION OR SECTION PROPERTIES	CONCRETE COVER ABOVE TOP OF METAL DECK (hf) OR (hc) (mm)							
		63.50	76.20	88.90	101.60	114.30	127.00	139.70	152.40
A	METAL DECK THICK (mm) (Td)	1.21	1.21	1.21	1.21	1.21	1.21	1.21	1.21
B	METAL DECK YIELD STRENGTH (KPa)(Fy)	280	280	280	280	280	280	280	280
C	METAL DECK EFF. (Ix) (mm ⁴)/m	6.95E+06	6.95E+06	6.95E+06	6.95E+06	6.95E+06	6.95E+06	6.95E+06	6.95E+06
D	METAL DECK EFF. (Sx) (mm ³)/m	6.18E+04	6.18E+04	6.18E+04	6.18E+04	6.18E+04	6.18E+04	6.18E+04	6.18E+04
E	METAL DECK (Es)(KPa)	2.03E+08	2.03E+08	2.03E+08	2.03E+08	2.03E+08	2.03E+08	2.03E+08	2.03E+08
F	# REINFORCING STEEL BAR DIA. (mm)	30	30	30	30	30	30	30	30
G	CONCRETE STRENGTH (f'c) (KPa)	3.00E+04	3.00E+04	3.00E+04	3.00E+04	3.00E+04	3.00E+04	3.00E+04	3.00E+04
H	CONCRETE (Ec) (KPa)	2.62E+07	2.62E+07	2.62E+07	2.62E+07	2.62E+07	2.62E+07	2.62E+07	2.62E+07
I	A _F (mm ²)/m	1830.917	1830.917	1830.917	1830.917	1830.917	1830.917	1830.917	1830.917
J	I _{x(f)} (mm ⁴)/m	9.80E+06	9.80E+06	9.80E+06	9.80E+06	9.80E+06	9.80E+06	9.80E+06	9.80E+06
K	ALLOWABLE FORCE (KN/m)	9.617	9.617	9.617	9.617	9.617	9.617	9.617	9.617
L	FINAL EFF. CROSS SECT. AREA A _{SO} (IN ²)	706	706	706	706	706	706	706	706
M	DEFLECTION CRITERIA K _{1,2,3,4}	1.333	1.333	1.333	1.333	1.333	1.333	1.333	1.333
N	DEFLECTION CRITERIA *	L/480	L/480	L/480	L/480	L/480	L/480	L/480	L/480

* DEFLECTION CRITERIA: L/360 (K₁=1), L/480 (K₂=1.333), L/600 (K₃=1.670) OR L/720 (K₄=2.0)
 # REINFORCING BAR Fy0=400MPa

OUTPUT SECTION #1

ITEM	DESCRIPTION	CONCRETE COVER ABOVE TOP OF METAL DECK (hf) OR (hc) (mm)							
		63.50	76.20	88.90	101.60	114.30	127.00	139.70	152.40
O	MAX. UNSHORED SPAN (C.L.1.006KPa).m.	4.28	3.95	3.67	3.43	3.21	3.02	2.86	2.71
P	MAX. UNSHORED SPAN (C.L.2.011KPa).m.	3.14	3.04	2.96	2.80	2.66	2.53	2.41	2.30
Q	TOTAL DEAD LOAD (NO CONST.),KPa.	2.586	2.885	3.184	3.484	3.783	4.082	4.381	4.680
R	CONCRETE VOLUME. m ³ /10m ²	1.000	1.127	1.254	1.381	1.508	1.635	1.762	1.889

C.L. = CONSTRUCTION LOAD (Pa)

OUTPUT SECTION #2: PLOT DATA - AND INPUT SECTION AS SHOWN #

ITEM	DESCRIPTION	(hf) OR (hc) (mm)	# MAXIMUM SPECIFIED UNIFORMLY DISTRIBUTED LOAD (KPa)							
			1.92	2.15	2.39	2.63	2.87	3.11	3.35	3.83
1	ALLOW. SINGLE UNSUP. SPAN - m.	63.50	10.22	9.83	9.49	9.19	8.93	8.70	8.48	8.11
2	ALLOW. SINGLE UNSUP. SPAN - m.	76.20	10.77	10.35	10.00	9.69	9.41	9.16	8.94	8.55
3	ALLOW. SINGLE UNSUP. SPAN - m.	88.90	11.32	10.88	10.51	10.18	9.89	9.63	9.39	8.98
4	ALLOW. SINGLE UNSUP. SPAN - m.	101.60	11.68	11.41	11.02	10.67	10.37	10.09	9.85	9.42
5	ALLOW. SINGLE UNSUP. SPAN - m.	114.30	11.63	11.42	11.23	11.04	10.85	10.56	10.30	9.86
6	ALLOW. SINGLE UNSUP. SPAN - m.	127.00	11.58	11.38	11.20	11.03	10.86	10.70	10.55	10.26
7	ALLOW. SINGLE UNSUP. SPAN - m.	139.70	11.53	11.35	11.17	11.01	10.85	10.70	10.55	10.28
8	ALLOW. SINGLE UNSUP. SPAN - m.	152.40	11.49	11.32	11.15	10.99	10.84	10.69	10.55	10.29

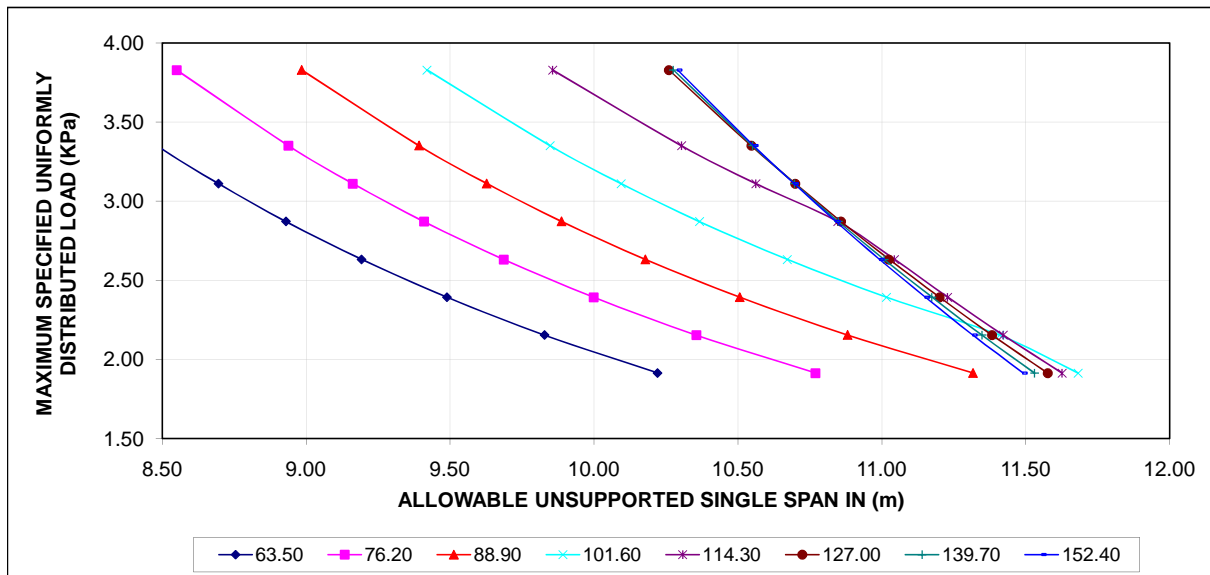



ULTRA-BOND COMPOSITE FLOOR DECK
 MAXIMUM SPECIFIED UNIFORMLY DISTRIBUTED LOAD (KPa)
 INCLUDES DEAD AND CONSTRUCTION LOAD CARRIED
 BY METAL DECK *(NOT SHOWN IN TABLES)*
 LIMIT STATE DESIGN (LSD) -METRIC UNITS

0.96mm Deck
10mm Rebar

INPUT SECTION:

ITEM	DESCRIPTION OR SECTION PROPERTIES	CONCRETE COVER ABOVE TOP OF METAL DECK (hf) OR (hc) (mm)							
		63.50	76.20	88.90	101.60	114.30	127.00	139.70	152.40
A	METAL DECK THICK (mm) (Td)	0.96	0.96	0.96	0.96	0.96	0.96	0.96	0.96
B	METAL DECK YIELD STRENGTH (KPa)(Fy)	280	280	280	280	280	280	280	280
C	METAL DECK EFF. (Ix) (mm ⁴ /m)	4.60E+06	4.60E+06	4.60E+06	4.60E+06	4.60E+06	4.60E+06	4.60E+06	4.60E+06
D	METAL DECK EFF. (Sx) (mm ³ /m)	3.68E+04	3.68E+04	3.68E+04	3.68E+04	3.68E+04	3.68E+04	3.68E+04	3.68E+04
E	METAL DECK (Es)(KPa)	2.03E+08	2.03E+08	2.03E+08	2.03E+08	2.03E+08	2.03E+08	2.03E+08	2.03E+08
F	# REINFORCING STEEL BAR DIA. (mm)	10	10	10	10	10	10	10	10
G	CONCRETE STRENGTH (f'c) (KPa)	3.00E+04	3.00E+04	3.00E+04	3.00E+04	3.00E+04	3.00E+04	3.00E+04	3.00E+04
H	CONCRETE (Ec) (KPa)	2.62E+07	2.62E+07	2.62E+07	2.62E+07	2.62E+07	2.62E+07	2.62E+07	2.62E+07
I	A _F (mm ² /m)	1454.150	1454.150	1454.150	1454.150	1454.150	1454.150	1454.150	1454.150
J	I _{x(F)} (mm ⁴ /m)	7.78E+06	7.78E+06	7.78E+06	7.78E+06	7.78E+06	7.78E+06	7.78E+06	7.78E+06
K	ALLOWABLE FORCE (KN/m)	6.378	6.378	6.378	6.378	6.378	6.378	6.378	6.378
L	FINAL EFF. CROSS SECT. AREA A _{SO} (IN ²)	240	240	240	240	240	240	240	240
M	DEFLECTION CRITERIA K _{1,2,3,4}	1.000	1.000	1.000	1.000	1.000	1.000	1.000	1.000

* DEFLECTION CRITERIA: L/360 (K₁=1), L/480 (K₂=1.333), L/600 (K₃=1.670) OR L/720 (K₄=2.0)
 # REINFORCING BAR Fy0=400MPa

OUTPUT SECTION #1

ITEM	DESCRIPTION	CONCRETE COVER ABOVE TOP OF METAL DECK (hf) OR (hc) (mm)							
		63.50	76.20	88.90	101.60	114.30	127.00	139.70	152.40
O	MAX. UNSHORED SPAN (C.L.1.006KPa).m.	2.89	2.66	2.47	2.30	2.16	2.03	1.92	1.81
P	MAX. UNSHORED SPAN (C.L.2.011KPa).m.	2.25	2.11	1.99	1.88	1.78	1.69	1.61	1.54
Q	TOTAL DEAD LOAD (NO CONST.)KPa.	2.526	2.826	3.125	3.424	3.723	4.022	4.321	4.620
R	CONCRETE VOLUME. m ³ /10m ²	1.021	1.147	1.274	1.401	1.528	1.655	1.782	1.909

C.L. = CONSTRUCTION LOAD (Pa)

OUTPUT SECTION #2: PLOT DATA - AND INPUT SECTION AS SHOWN #

ITEM	DESCRIPTION	(hf) OR (hc) (mm)	# MAXIMUM SPECIFIED UNIFORMLY DISTRIBUTED LOAD (KPa)							
			1.92	2.15	2.39	2.63	2.87	3.11	3.35	3.83
1	ALLOW. SINGLE UNSUP. SPAN - m.	63.50	7.08	6.92	6.77	6.63	6.50	6.37	6.25	6.04
2	ALLOW. SINGLE UNSUP. SPAN - m.	76.20	7.03	6.88	6.74	6.60	6.48	6.36	6.25	6.04
3	ALLOW. SINGLE UNSUP. SPAN - m.	88.90	6.98	6.84	6.71	6.58	6.47	6.35	6.25	6.05
4	ALLOW. SINGLE UNSUP. SPAN - m.	101.60	6.93	6.80	6.68	6.56	6.45	6.35	6.25	6.06
5	ALLOW. SINGLE UNSUP. SPAN - m.	114.30	6.89	6.77	6.65	6.54	6.44	6.34	6.24	6.07
6	ALLOW. SINGLE UNSUP. SPAN - m.	127.00	6.86	6.74	6.63	6.53	6.43	6.33	6.24	6.07
7	ALLOW. SINGLE UNSUP. SPAN - m.	139.70	6.83	6.72	6.61	6.51	6.42	6.33	6.24	6.08
8	ALLOW. SINGLE UNSUP. SPAN - m.	152.40	6.80	6.69	6.59	6.50	6.41	6.32	6.24	6.08

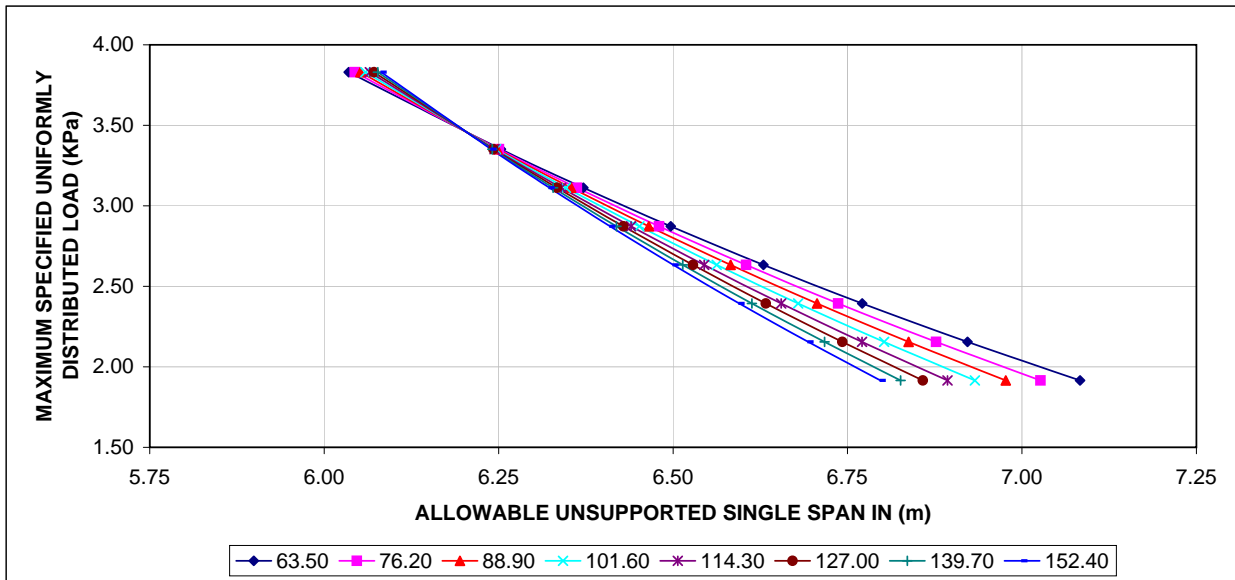



ULTRA-BOND COMPOSITE FLOOR DECK
 MAXIMUM SPECIFIED UNIFORMLY DISTRIBUTED LOAD (KPa)
 INCLUDES DEAD AND CONSTRUCTION LOAD CARRIED
 BY METAL DECK *(NOT SHOWN IN TABLES)*
 LIMIT STATE DESIGN (LSD) -METRIC UNITS

0.96mm Deck
15mm Rebar

INPUT SECTION:

ITEM	DESCRIPTION OR SECTION PROPERTIES	CONCRETE COVER ABOVE TOP OF METAL DECK (hf) OR (hc) (mm)							
		63.50	76.20	88.90	101.60	114.30	127.00	139.70	152.40
A	METAL DECK THICK (mm) (Td)	0.96	0.96	0.96	0.96	0.96	0.96	0.96	0.96
B	METAL DECK YIELD STRENGTH (KPa)(Fy)	280	280	280	280	280	280	280	280
C	METAL DECK EFF. (Ix) (mm ⁴ /m)	4.60E+06	4.60E+06	4.60E+06	4.60E+06	4.60E+06	4.60E+06	4.60E+06	4.60E+06
D	METAL DECK EFF. (Sx) (mm ³ /m)	3.68E+04	3.68E+04	3.68E+04	3.68E+04	3.68E+04	3.68E+04	3.68E+04	3.68E+04
E	METAL DECK (Es)(KPa)	2.03E+08	2.03E+08	2.03E+08	2.03E+08	2.03E+08	2.03E+08	2.03E+08	2.03E+08
F	# REINFORCING STEEL BAR DIA. (mm)	15	15	15	15	15	15	15	15
G	CONCRETE STRENGTH (f'c) (KPa)	3.00E+04	3.00E+04	3.00E+04	3.00E+04	3.00E+04	3.00E+04	3.00E+04	3.00E+04
H	CONCRETE (Ec) (KPa)	2.62E+07	2.62E+07	2.62E+07	2.62E+07	2.62E+07	2.62E+07	2.62E+07	2.62E+07
I	A _F (mm ² /m)	1454.150	1454.150	1454.150	1454.150	1454.150	1454.150	1454.150	1454.150
J	I _{x(F)} (mm ⁴ /m)	7.78E+06	7.78E+06	7.78E+06	7.78E+06	7.78E+06	7.78E+06	7.78E+06	7.78E+06
K	ALLOWABLE FORCE (KN/m)	6.378	6.378	6.378	6.378	6.378	6.378	6.378	6.378
L	FINAL EFF. CROSS SECT. AREA A _{SO} (IN ²)	323	323	323	323	323	323	323	323
M	DEFLECTION CRITERIA K _{1,2,3,4}	1.000	1.000	1.000	1.000	1.000	1.000	1.000	1.000

* DEFLECTION CRITERIA: L/360 (K₁=1), L/480 (K₂=1.333), L/600 (K₃=1.670) OR L/720 (K₄=2.0)
 # REINFORCING BAR Fy0=400MPa

OUTPUT SECTION #1

ITEM	DESCRIPTION	CONCRETE COVER ABOVE TOP OF METAL DECK (hf) OR (hc) (mm)							
		63.50	76.20	88.90	101.60	114.30	127.00	139.70	152.40
O	MAX. UNSHORED SPAN (C.L.1.006KPa).m.	2.89	2.66	2.47	2.30	2.16	2.03	1.91	1.81
P	MAX. UNSHORED SPAN (C.L.2.011KPa).m.	2.25	2.11	1.99	1.88	1.78	1.69	1.61	1.54
Q	TOTAL DEAD LOAD (NO CONST.)KPa.	2.531	2.830	3.129	3.429	3.728	4.027	4.326	4.625
R	CONCRETE VOLUME. m ³ /10m ²	1.017	1.144	1.271	1.398	1.525	1.652	1.779	1.906

C.L. = CONSTRUCTION LOAD (Pa)

OUTPUT SECTION #2: PLOT DATA - AND INPUT SECTION AS SHOWN #

ITEM	DESCRIPTION	(hf) OR (hc) (mm)	# MAXIMUM SPECIFIED UNIFORMLY DISTRIBUTED LOAD (KPa)							
			1.92	2.15	2.39	2.63	2.87	3.11	3.35	3.83
1	ALLOW. SINGLE UNSUP. SPAN - m.	63.50	8.19	8.00	7.83	7.66	7.51	7.37	7.23	6.98
2	ALLOW. SINGLE UNSUP. SPAN - m.	76.20	8.12	7.95	7.79	7.64	7.49	7.36	7.23	6.99
3	ALLOW. SINGLE UNSUP. SPAN - m.	88.90	8.07	7.91	7.75	7.61	7.48	7.35	7.23	7.00
4	ALLOW. SINGLE UNSUP. SPAN - m.	101.60	8.02	7.87	7.72	7.59	7.46	7.34	7.22	7.01
5	ALLOW. SINGLE UNSUP. SPAN - m.	114.30	7.97	7.83	7.70	7.57	7.45	7.33	7.22	7.02
6	ALLOW. SINGLE UNSUP. SPAN - m.	127.00	7.93	7.80	7.67	7.55	7.44	7.33	7.22	7.02
7	ALLOW. SINGLE UNSUP. SPAN - m.	139.70	7.90	7.77	7.65	7.54	7.43	7.32	7.22	7.03
8	ALLOW. SINGLE UNSUP. SPAN - m.	152.40	7.86	7.74	7.63	7.52	7.42	7.32	7.22	7.04

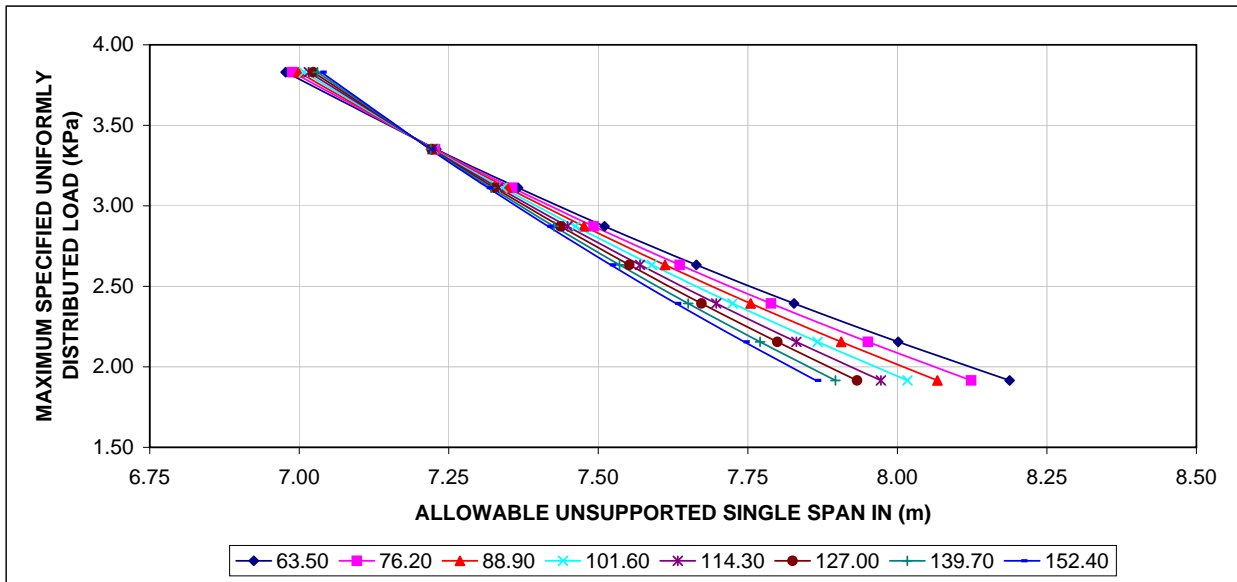



ULTRA-BOND COMPOSITE FLOOR DECK
 MAXIMUM SPECIFIED UNIFORMLY DISTRIBUTED LOAD (KPa)
 INCLUDES DEAD AND CONSTRUCTION LOAD CARRIED
 BY METAL DECK *(NOT SHOWN IN TABLES)*
 LIMIT STATE DESIGN (LSD) -METRIC UNITS

0.96mm Deck
20mm Rebar

INPUT SECTION:

ITEM	DESCRIPTION OR SECTION PROPERTIES	CONCRETE COVER ABOVE TOP OF METAL DECK (hf) OR (hc) (mm)							
		63.50	76.20	88.90	101.60	114.30	127.00	139.70	152.40
A	METAL DECK THICK (mm) (Td)	0.96	0.96	0.96	0.96	0.96	0.96	0.96	0.96
B	METAL DECK YIELD STRENGTH (KPa)(Fy)	280	280	280	280	280	280	280	280
C	METAL DECK EFF. (Ix) (mm ⁴)/m	4.60E+06	4.60E+06	4.60E+06	4.60E+06	4.60E+06	4.60E+06	4.60E+06	4.60E+06
D	METAL DECK EFF. (Sx) (mm ³)/m	3.68E+04	3.68E+04	3.68E+04	3.68E+04	3.68E+04	3.68E+04	3.68E+04	3.68E+04
E	METAL DECK (Es)(KPa)	2.03E+08	2.03E+08	2.03E+08	2.03E+08	2.03E+08	2.03E+08	2.03E+08	2.03E+08
F	# REINFORCING STEEL BAR DIA. (mm)	20	20	20	20	20	20	20	20
G	CONCRETE STRENGTH (f'c) (KPa)	3.00E+04	3.00E+04	3.00E+04	3.00E+04	3.00E+04	3.00E+04	3.00E+04	3.00E+04
H	CONCRETE (Ec) (KPa)	2.62E+07	2.62E+07	2.62E+07	2.62E+07	2.62E+07	2.62E+07	2.62E+07	2.62E+07
I	A _F (mm ²)/m	1454.150	1454.150	1454.150	1454.150	1454.150	1454.150	1454.150	1454.150
J	I _{x(F)} (mm ⁴)/m	7.78E+06	7.78E+06	7.78E+06	7.78E+06	7.78E+06	7.78E+06	7.78E+06	7.78E+06
K	ALLOWABLE FORCE (KN/m)	6.378	6.378	6.378	6.378	6.378	6.378	6.378	6.378
L	FINAL EFF. CROSS SECT. AREA A _{SO} (IN ²)	361	361	361	361	361	361	361	361
M	DEFLECTION CRITERIA K _{1,2,3,4}	1.000	1.000	1.000	1.000	1.000	1.000	1.000	1.000

* DEFLECTION CRITERIA: L/360 (K₁=1), L/480 (K₂=1.333), L/600 (K₃=1.670) OR L/720 (K₄=2.0)

OUTPUT SECTION #1

ITEM	DESCRIPTION	CONCRETE COVER ABOVE TOP OF METAL DECK (hf) OR (hc) (mm)							
		63.50	76.20	88.90	101.60	114.30	127.00	139.70	152.40
O	MAX. UNSHORED SPAN (C.L.1.006KPa).m.	2.88	2.66	2.46	2.30	2.15	2.02	1.91	1.81
P	MAX. UNSHORED SPAN (C.L.2.011KPa).m.	2.24	2.10	1.98	1.87	1.78	1.69	1.61	1.54
Q	TOTAL DEAD LOAD (NO CONST.).KPa.	2.538	2.837	3.136	3.435	3.734	4.034	4.333	4.632
R	CONCRETE VOLUME. m ³ /10m ²	1.013	1.140	1.267	1.394	1.521	1.648	1.775	1.901

C.L. = CONSTRUCTION LOAD (Pa)

OUTPUT SECTION #2: PLOT DATA - AND INPUT SECTION AS SHOWN #

ITEM	DESCRIPTION	(hf) OR (hc) (mm)	# MAXIMUM SPECIFIED UNIFORMLY DISTRIBUTED LOAD (KPa)							
			1.92	2.15	2.39	2.63	2.87	3.11	3.35	3.83
1	ALLOW. SINGLE UNSUP. SPAN - m.	63.50	8.65	8.45	8.27	8.10	7.93	7.78	7.64	7.37
2	ALLOW. SINGLE UNSUP. SPAN - m.	76.20	8.58	8.40	8.23	8.07	7.92	7.77	7.64	7.38
3	ALLOW. SINGLE UNSUP. SPAN - m.	88.90	8.52	8.35	8.19	8.04	7.90	7.76	7.63	7.40
4	ALLOW. SINGLE UNSUP. SPAN - m.	101.60	8.47	8.31	8.16	8.02	7.88	7.76	7.63	7.41
5	ALLOW. SINGLE UNSUP. SPAN - m.	114.30	8.42	8.28	8.13	8.00	7.87	7.75	7.63	7.41
6	ALLOW. SINGLE UNSUP. SPAN - m.	127.00	8.38	8.24	8.11	7.98	7.86	7.74	7.63	7.42
7	ALLOW. SINGLE UNSUP. SPAN - m.	139.70	8.35	8.21	8.09	7.96	7.85	7.74	7.63	7.43
8	ALLOW. SINGLE UNSUP. SPAN - m.	152.40	8.31	8.18	8.06	7.95	7.84	7.73	7.63	7.44

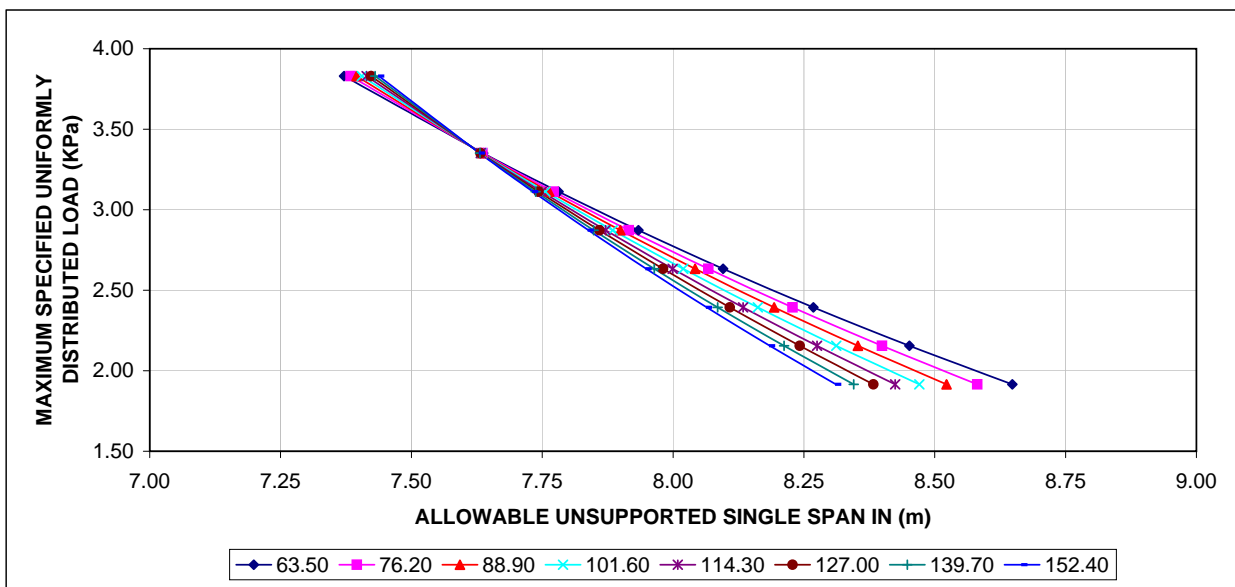



ULTRA-BOND COMPOSITE FLOOR DECK
 MAXIMUM SPECIFIED UNIFORMLY DISTRIBUTED LOAD (KPa)
 INCLUDES DEAD AND CONSTRUCTION LOAD CARRIED
 BY METAL DECK *(NOT SHOWN IN TABLES)*
 LIMIT STATE DESIGN (LSD) -METRIC UNITS

0.96mm Deck
25mm Rebar

INPUT SECTION:

ITEM	DESCRIPTION OR SECTION PROPERTIES	CONCRETE COVER ABOVE TOP OF METAL DECK (hf) OR (hc) (mm)							
		63.50	76.20	88.90	101.60	114.30	127.00	139.70	152.40
A	METAL DECK THICK (mm) (Td)	0.96	0.96	0.96	0.96	0.96	0.96	0.96	0.96
B	METAL DECK YIELD STRENGTH (KPa)(Fy)	280	280	280	280	280	280	280	280
C	METAL DECK EFF. (Ix) (mm ⁴)/m	4.60E+06	4.60E+06	4.60E+06	4.60E+06	4.60E+06	4.60E+06	4.60E+06	4.60E+06
D	METAL DECK EFF. (Sx) (mm ³)/m	3.68E+04	3.68E+04	3.68E+04	3.68E+04	3.68E+04	3.68E+04	3.68E+04	3.68E+04
E	METAL DECK (Es)(KPa)	2.03E+08	2.03E+08	2.03E+08	2.03E+08	2.03E+08	2.03E+08	2.03E+08	2.03E+08
F	# REINFORCING STEEL BAR DIA. (mm)	25	25	25	25	25	25	25	25
G	CONCRETE STRENGTH (f'c) (KPa)	3.00E+04	3.00E+04	3.00E+04	3.00E+04	3.00E+04	3.00E+04	3.00E+04	3.00E+04
H	CONCRETE (Ec) (KPa)	2.62E+07	2.62E+07	2.62E+07	2.62E+07	2.62E+07	2.62E+07	2.62E+07	2.62E+07
I	A _F (mm ²)/m	1454.150	1454.150	1454.150	1454.150	1454.150	1454.150	1454.150	1454.150
J	I _{x(F)} (mm ⁴)/m	7.78E+06	7.78E+06	7.78E+06	7.78E+06	7.78E+06	7.78E+06	7.78E+06	7.78E+06
K	ALLOWABLE FORCE (KN/m)	6.378	6.378	6.378	6.378	6.378	6.378	6.378	6.378
L	FINAL EFF. CROSS SECT. AREA A _{SO} (IN ²)	490	490	490	490	490	490	490	490
M	DEFLECTION CRITERIA K _{1,2,3,4}	1.000	1.000	1.000	1.000	1.000	1.000	1.000	1.000

* DEFLECTION CRITERIA: L/360 (K₁=1), L/480 (K₂=1.333), L/600 (K₃=1.670) OR L/720 (K₄=2.0)
 # REINFORCING BAR Fy0=400MPa

OUTPUT SECTION #1

ITEM	DESCRIPTION	CONCRETE COVER ABOVE TOP OF METAL DECK (hf) OR (hc) (mm)							
		63.50	76.20	88.90	101.60	114.30	127.00	139.70	152.40
O	MAX. UNSHORED SPAN (C.L.1.006KPa).m.	2.87	2.65	2.46	2.29	2.15	2.02	1.91	1.81
P	MAX. UNSHORED SPAN (C.L.2.011KPa).m.	2.24	2.10	1.98	1.87	1.77	1.69	1.61	1.53
Q	TOTAL DEAD LOAD (NO CONST.)KPa.	2.547	2.846	3.145	3.444	3.743	4.042	4.341	4.641
R	CONCRETE VOLUME. m ³ /10m ²	1.007	1.134	1.261	1.388	1.515	1.642	1.769	1.896

C.L. = CONSTRUCTION LOAD (Pa)

OUTPUT SECTION #2: PLOT DATA - AND INPUT SECTION AS SHOWN #

ITEM	DESCRIPTION	(hf) OR (hc) (mm)	# MAXIMUM SPECIFIED UNIFORMLY DISTRIBUTED LOAD (KPa)							
			1.92	2.15	2.39	2.63	2.87	3.11	3.35	3.83
1	ALLOW. SINGLE UNSUP. SPAN - m.	63.50	10.03	9.80	9.59	9.39	9.20	9.02	8.86	8.55
2	ALLOW. SINGLE UNSUP. SPAN - m.	76.20	9.95	9.74	9.54	9.36	9.18	9.01	8.86	8.57
3	ALLOW. SINGLE UNSUP. SPAN - m.	88.90	9.89	9.69	9.50	9.33	9.16	9.01	8.86	8.58
4	ALLOW. SINGLE UNSUP. SPAN - m.	101.60	9.83	9.64	9.47	9.31	9.15	9.00	8.86	8.59
5	ALLOW. SINGLE UNSUP. SPAN - m.	114.30	9.78	9.60	9.44	9.28	9.14	8.99	8.86	8.61
6	ALLOW. SINGLE UNSUP. SPAN - m.	127.00	9.73	9.57	9.41	9.26	9.12	8.99	8.86	8.62
7	ALLOW. SINGLE UNSUP. SPAN - m.	139.70	9.69	9.53	9.39	9.25	9.11	8.98	8.86	8.63
8	ALLOW. SINGLE UNSUP. SPAN - m.	152.40	9.65	9.50	9.36	9.23	9.10	8.98	8.86	8.64

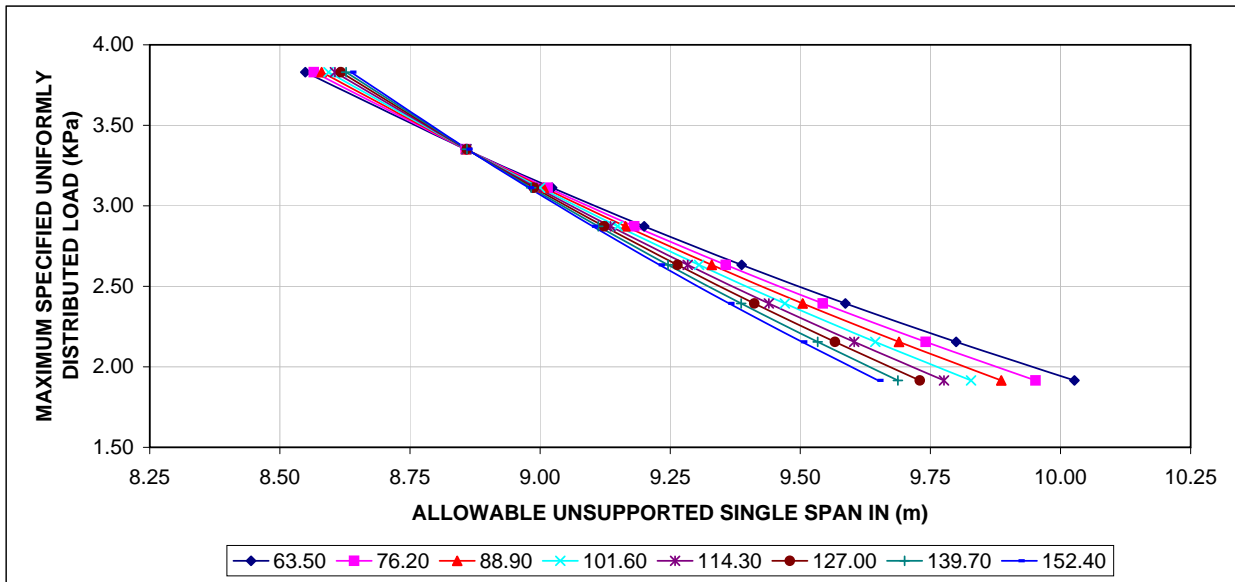



ULTRA-BOND COMPOSITE FLOOR DECK
 MAXIMUM SPECIFIED UNIFORMLY DISTRIBUTED LOAD (KPa)
 INCLUDES DEAD AND CONSTRUCTION LOAD CARRIED
 BY METAL DECK *(NOT SHOWN IN TABLES)*
 LIMIT STATE DESIGN (LSD) -METRIC UNITS

0.96mm Deck
30mm Rebar

INPUT SECTION:

ITEM	DESCRIPTION OR SECTION PROPERTIES	CONCRETE COVER ABOVE TOP OF METAL DECK (hf) OR (hc) (mm)							
		63.50	76.20	88.90	101.60	114.30	127.00	139.70	152.40
A	METAL DECK THICK (mm) (Td)	0.96	0.96	0.96	0.96	0.96	0.96	0.96	0.96
B	METAL DECK YIELD STRENGTH (KPa)(Fy)	280	280	280	280	280	280	280	280
C	METAL DECK EFF. (Ix) (mm ⁴ /m)	4.60E+06	4.60E+06	4.60E+06	4.60E+06	4.60E+06	4.60E+06	4.60E+06	4.60E+06
D	METAL DECK EFF. (Sx) (mm ³ /m)	3.68E+04	3.68E+04	3.68E+04	3.68E+04	3.68E+04	3.68E+04	3.68E+04	3.68E+04
E	METAL DECK (Es)(KPa)	2.03E+08	2.03E+08	2.03E+08	2.03E+08	2.03E+08	2.03E+08	2.03E+08	2.03E+08
F	# REINFORCING STEEL BAR DIA. (mm)	30	30	30	30	30	30	30	30
G	CONCRETE STRENGTH (f'c) (KPa)	3.00E+04	3.00E+04	3.00E+04	3.00E+04	3.00E+04	3.00E+04	3.00E+04	3.00E+04
H	CONCRETE (Ec) (KPa)	2.62E+07	2.62E+07	2.62E+07	2.62E+07	2.62E+07	2.62E+07	2.62E+07	2.62E+07
I	A _F (mm ² /m)	1454.150	1454.150	1454.150	1454.150	1454.150	1454.150	1454.150	1454.150
J	I _{x(F)} (mm ⁴ /m)	7.78E+06	7.78E+06	7.78E+06	7.78E+06	7.78E+06	7.78E+06	7.78E+06	7.78E+06
K	ALLOWABLE FORCE (KN/m)	6.378	6.378	6.378	6.378	6.378	6.378	6.378	6.378
L	FINAL EFF. CROSS SECT. AREA A _{SO} (IN ²)	706	706	706	706	706	706	706	706
M	DEFLECTION CRITERIA K _{1,2,3,4}	1.000	1.000	1.000	1.000	1.000	1.000	1.000	1.000

* DEFLECTION CRITERIA: L/360 (K₁=1), L/480 (K₂=1.333), L/600 (K₃=1.670) OR L/720 (K₄=2.0)
 # REINFORCING BAR Fy0=400MPa

OUTPUT SECTION #1

ITEM	DESCRIPTION	CONCRETE COVER ABOVE TOP OF METAL DECK (hf) OR (hc) (mm)							
		63.50	76.20	88.90	101.60	114.30	127.00	139.70	152.40
O	MAX. UNSHORED SPAN (C.L.1.006KPa).m.	2.86	2.64	2.45	2.29	2.14	2.02	1.90	1.80
P	MAX. UNSHORED SPAN (C.L.2.011KPa).m.	2.23	2.10	1.98	1.87	1.77	1.68	1.60	1.53
Q	TOTAL DEAD LOAD (NO CONST.)KPa.	2.557	2.856	3.155	3.455	3.754	4.053	4.352	4.651
R	CONCRETE VOLUME. m ³ /10m ²	1.000	1.127	1.254	1.381	1.508	1.635	1.762	1.889

C.L. = CONSTRUCTION LOAD (Pa)

OUTPUT SECTION #2: PLOT DATA - AND INPUT SECTION AS SHOWN #

ITEM	DESCRIPTION	(hf) OR (hc) (mm)	# MAXIMUM SPECIFIED UNIFORMLY DISTRIBUTED LOAD (KPa)							
			1.92	2.15	2.39	2.63	2.87	3.11	3.35	3.83
1	ALLOW. SINGLE UNSUP. SPAN - m.	63.50	11.07	10.64	10.28	9.96	9.67	9.42	9.19	8.79
2	ALLOW. SINGLE UNSUP. SPAN - m.	76.20	11.67	11.22	10.84	10.50	10.20	9.93	9.69	9.27
3	ALLOW. SINGLE UNSUP. SPAN - m.	88.90	11.79	11.55	11.33	11.04	10.72	10.44	10.19	9.74
4	ALLOW. SINGLE UNSUP. SPAN - m.	101.60	11.72	11.50	11.30	11.10	10.91	10.74	10.57	10.22
5	ALLOW. SINGLE UNSUP. SPAN - m.	114.30	11.66	11.46	11.26	11.08	10.90	10.73	10.57	10.27
6	ALLOW. SINGLE UNSUP. SPAN - m.	127.00	11.61	11.42	11.23	11.06	10.89	10.73	10.57	10.29
7	ALLOW. SINGLE UNSUP. SPAN - m.	139.70	11.56	11.38	11.20	11.04	10.88	10.72	10.58	10.30
8	ALLOW. SINGLE UNSUP. SPAN - m.	152.40	11.52	11.35	11.18	11.02	10.87	10.72	10.58	10.31

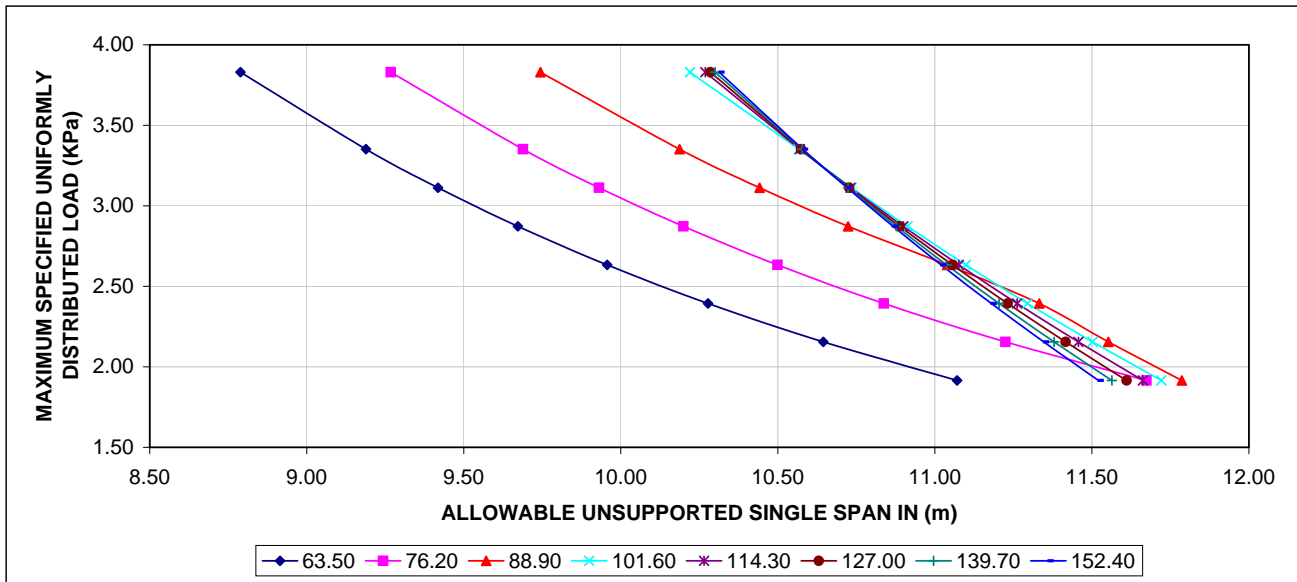



ULTRA-BOND COMPOSITE FLOOR DECK
 MAXIMUM SPECIFIED UNIFORMLY DISTRIBUTED LOAD (P.S.F)
 INCLUDES DEAD AND CONSTRUCTION LOAD CARRIED
 BY METAL DECK *(NOT SHOWN IN TABLES)*
 LIMIT STATE DESIGN (LSD) - **IMPERIAL UNITS**

0.0476" Deck
0.394" Rebar

INPUT SECTION:

ITEM	DESCRIPTION OR SECTION PROPERTIES	CONCRETE COVER ABOVE TOP OF METAL DECK (hf) OR (hc) (IN)							
		2.50	3.00	3.50	4.00	4.50	5.00	5.50	6.00
A	METAL DECK THICK (INCH) (Td)	0.0476	0.0476	0.0476	0.0476	0.0476	0.0476	0.0476	0.0476
B	METAL DECK YIELD STRENGTH (KSI)(Fy)	40.6	40.6	40.6	40.6	40.6	40.6	40.6	40.6
C	METAL DECK EFF. (Ix) (IN ⁴)/FT	5.09	5.09	5.09	5.09	5.09	5.09	5.09	5.09
D	METAL DECK EFF. (Sx) (IN ³)/FT	1.15	1.15	1.15	1.15	1.15	1.15	1.15	1.15
E	METAL DECK (Es)(PSI)	2.95E+07	2.95E+07	2.95E+07	2.95E+07	2.95E+07	2.95E+07	2.95E+07	2.95E+07
F	# REINFORCING STEEL BAR DIA. (INCH)	0.394	0.394	0.394	0.394	0.394	0.394	0.394	0.394
G	CONCRETE STRENGTH (f'c) (PSI)	4350	4350	4350	4350	4350	4350	4350	4350
H	CONCRETE (Ec) (PSI)	3.80E+06	3.80E+06	3.80E+06	3.80E+06	3.80E+06	3.80E+06	3.80E+06	3.80E+06
I	A _F (IN ²)/FT	0.865	0.865	0.865	0.865	0.865	0.865	0.865	0.865
J	I _{x(F)} (IN ⁴)/FT	7.18	7.18	7.18	7.18	7.18	7.18	7.18	7.18
K	ALLOWABLE FORCE (LBS/FT)	659	659	659	659	659	659	659	659
L	FINAL EFF. CROSS SECT. AREA A _{SO} (IN ²)	0.467	0.467	0.467	0.467	0.467	0.467	0.467	0.467
M	DEFLECTION CRITERIA K _{1,2,3,4}	1.333	1.333	1.333	1.333	1.333	1.333	1.333	1.333
N	DEFLECTION CRITERIA *	L/480	L/480	L/480	L/480	L/480	L/480	L/480	L/480

* DEFLECTION CRITERIA: L/360 (K₁=1), L/480 (K₂=1.333), L/600 (K₃=1.670) OR L/720 (K₄=2.0)
 # REINFORCING BAR Fy0=58.0KSI

OUTPUT SECTION #1

ITEM	DESCRIPTION	CONCRETE COVER ABOVE TOP OF METAL DECK (hf) OR (hc) (IN)							
		2.50	3.00	3.50	4.00	4.50	5.00	5.50	6.00
O	MAX. UNSHORED SPAN (C.L.21PSF).FT.	14.18	13.08	12.14	11.32	10.61	9.98	9.43	8.93
P	MAX. UNSHORED SPAN (C.L.42PSF).FT.	10.24	9.78	9.52	9.24	8.76	8.33	7.94	7.58
Q	TOTAL DEAD LOAD (NO CONST.).PSF.	53.37	59.62	65.87	72.11	78.36	84.61	90.86	97.10
R	CONCRETE VOLUME. YD ³ /100FT ²	1.240	1.394	1.549	1.703	1.857	2.011	2.166	2.320

C.L. = CONSTRUCTION LOAD (PSF)

OUTPUT SECTION #2: PLOT DATA - AND INPUT SECTION AS SHOWN #

ITEM	DESCRIPTION	(hf) OR (hc) (IN)	# MAXIMUM SPECIFIED UNIFORMLY DISTRIBUTED LOAD (P.S.F)							
			85	90	100	110	120	130	140	145
1	ALLOW. SINGLE UNSUP. SPAN - FT.	2.50	21.71	21.36	20.71	20.12	19.57	19.07	18.60	18.38
2	ALLOW. SINGLE UNSUP. SPAN - FT.	3.00	21.76	21.43	20.81	20.24	19.71	19.22	18.77	18.55
3	ALLOW. SINGLE UNSUP. SPAN - FT.	3.50	21.81	21.50	20.90	20.35	19.84	19.37	18.93	18.72
4	ALLOW. SINGLE UNSUP. SPAN - FT.	4.00	21.86	21.55	20.98	20.45	19.96	19.50	19.07	18.87
5	ALLOW. SINGLE UNSUP. SPAN - FT.	4.50	21.90	21.61	21.06	20.54	20.07	19.62	19.20	19.01
6	ALLOW. SINGLE UNSUP. SPAN - FT.	5.00	21.94	21.66	21.12	20.63	20.17	19.73	19.33	19.14
7	ALLOW. SINGLE UNSUP. SPAN - FT.	5.50	21.97	21.70	21.19	20.71	20.26	19.84	19.45	19.26
8	ALLOW. SINGLE UNSUP. SPAN - FT.	6.00	22.01	21.74	21.25	20.78	20.35	19.94	19.55	19.37

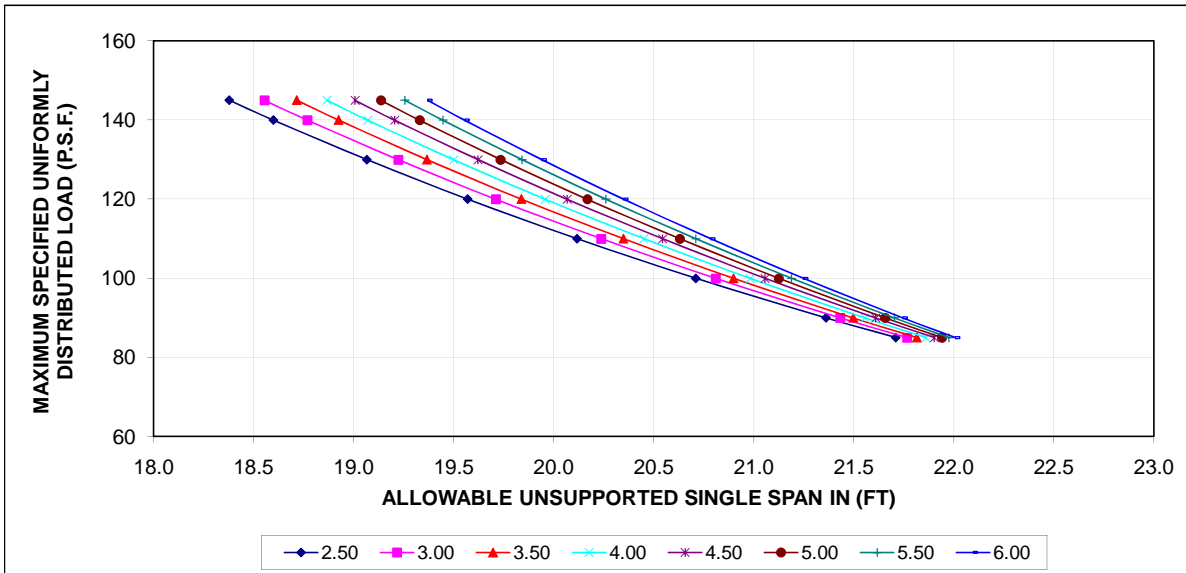



ULTRA-BOND COMPOSITE FLOOR DECK
 MAXIMUM SPECIFIED UNIFORMLY DISTRIBUTED LOAD (P.S.F)
 INCLUDES DEAD AND CONSTRUCTION LOAD CARRIED
 BY METAL DECK *(NOT SHOWN IN TABLES)*
 LIMIT STATE DESIGN (LSD) - **IMPERIAL UNITS**

0.0476" Deck
0.591" Rebar

INPUT SECTION:

ITEM	DESCRIPTION OR SECTION PROPERTIES	CONCRETE COVER ABOVE TOP OF METAL DECK (hf) OR (hc) (IN)							
		2.50	3.00	3.50	4.00	4.50	5.00	5.50	6.00
A	METAL DECK THICK (INCH) (Td)	0.0476	0.0476	0.0476	0.0476	0.0476	0.0476	0.0476	0.0476
B	METAL DECK YIELD STRENGTH (KSI)(Fy)	40.6	40.6	40.6	40.6	40.6	40.6	40.6	40.6
C	METAL DECK EFF. (Ix) (IN ⁴)/FT	5.09	5.09	5.09	5.09	5.09	5.09	5.09	5.09
D	METAL DECK EFF. (Sx) (IN ³)/FT	1.15	1.15	1.15	1.15	1.15	1.15	1.15	1.15
E	METAL DECK (Es)(PSI)	2.95E+07	2.95E+07	2.95E+07	2.95E+07	2.95E+07	2.95E+07	2.95E+07	2.95E+07
F	# REINFORCING STEEL BAR DIA. (INCH)	0.591	0.591	0.591	0.591	0.591	0.591	0.591	0.591
G	CONCRETE STRENGTH (f'c) (PSI)	4350	4350	4350	4350	4350	4350	4350	4350
H	CONCRETE (Ec) (PSI)	3.80E+06	3.80E+06	3.80E+06	3.80E+06	3.80E+06	3.80E+06	3.80E+06	3.80E+06
I	A _F (IN ²)/FT	0.865	0.865	0.865	0.865	0.865	0.865	0.865	0.865
J	I _{x(F)} (IN ⁴)/FT	7.18	7.18	7.18	7.18	7.18	7.18	7.18	7.18
K	ALLOWABLE FORCE (LBS/FT)	659	659	659	659	659	659	659	659
L	FINAL EFF. CROSS SECT. AREA A _{SO} (IN ²)	0.600	0.600	0.600	0.600	0.600	0.600	0.600	0.600
M	DEFLECTION CRITERIA K _{1,2,3,4}	1.333	1.333	1.333	1.333	1.333	1.333	1.333	1.333
N	DEFLECTION CRITERIA *	L/480	L/480	L/480	L/480	L/480	L/480	L/480	L/480

* DEFLECTION CRITERIA: L/360 (K₁=1), L/480 (K₂=1.333), L/600 (K₃=1.670) OR L/720 (K₄=2.0)
 # REINFORCING BAR Fy0=58.0KSI

OUTPUT SECTION #1

ITEM	DESCRIPTION	CONCRETE COVER ABOVE TOP OF METAL DECK (hf) OR (hc) (IN)							
		2.50	3.00	3.50	4.00	4.50	5.00	5.50	6.00
O	MAX. UNSHORED SPAN (C.L.21PSF).FT.	14.16	13.06	12.12	11.31	10.60	9.97	9.42	8.92
P	MAX. UNSHORED SPAN (C.L.42PSF).FT.	10.25	9.77	9.53	9.23	8.75	8.32	7.93	7.57
Q	TOTAL DEAD LOAD (NO CONST.).PSF.	53.47	59.72	65.97	72.21	78.46	84.71	90.96	97.20
R	CONCRETE VOLUME. YD ³ /100FT ²	1.236	1.390	1.545	1.699	1.853	2.007	2.162	2.316

C.L. = CONSTRUCTION LOAD (PSF)

OUTPUT SECTION #2: PLOT DATA - AND INPUT SECTION AS SHOWN #

ITEM	DESCRIPTION	(hf) OR (hc) (IN)	# MAXIMUM SPECIFIED UNIFORMLY DISTRIBUTED LOAD (P.S.F)							
			85	90	100	110	120	130	140	145
1	ALLOW. SINGLE UNSUP. SPAN - FT.	2.50	24.54	24.14	23.41	22.74	22.12	21.55	21.02	20.77
2	ALLOW. SINGLE UNSUP. SPAN - FT.	3.00	24.60	24.23	23.52	22.88	22.28	21.73	21.22	20.98
3	ALLOW. SINGLE UNSUP. SPAN - FT.	3.50	24.66	24.30	23.63	23.01	22.43	21.90	21.40	21.16
4	ALLOW. SINGLE UNSUP. SPAN - FT.	4.00	24.72	24.37	23.72	23.12	22.57	22.05	21.56	21.33
5	ALLOW. SINGLE UNSUP. SPAN - FT.	4.50	24.77	24.44	23.81	23.23	22.69	22.19	21.72	21.49
6	ALLOW. SINGLE UNSUP. SPAN - FT.	5.00	24.81	24.49	23.89	23.33	22.81	22.32	21.86	21.64
7	ALLOW. SINGLE UNSUP. SPAN - FT.	5.50	24.85	24.55	23.97	23.42	22.92	22.44	22.00	21.78
8	ALLOW. SINGLE UNSUP. SPAN - FT.	6.00	24.89	24.60	24.03	23.51	23.02	22.56	22.12	21.91

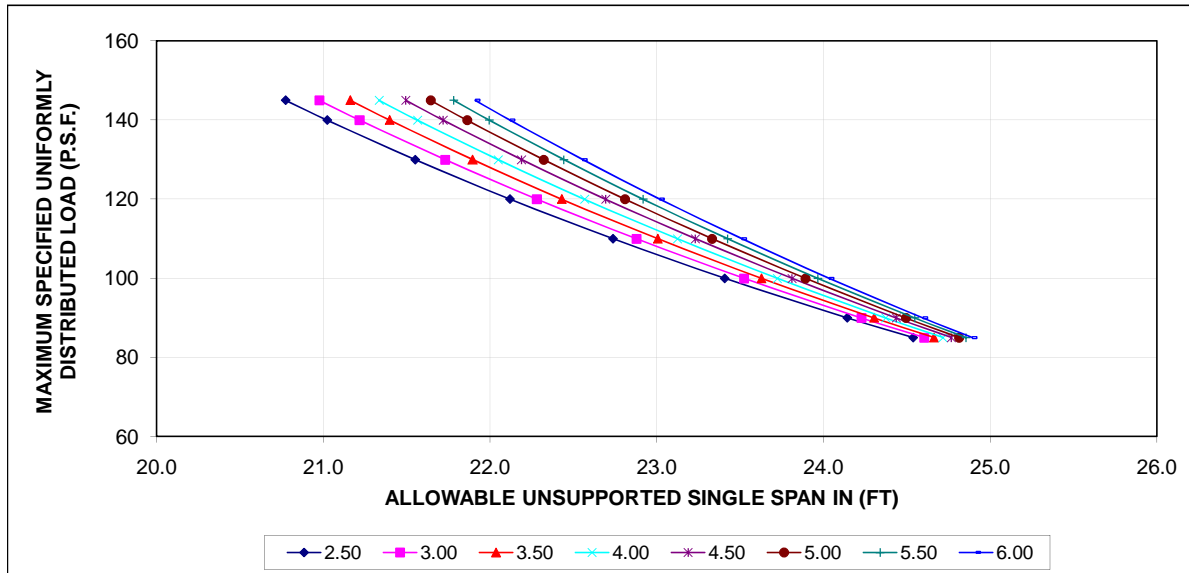



ULTRA-BOND COMPOSITE FLOOR DECK
 MAXIMUM SPECIFIED UNIFORMLY DISTRIBUTED LOAD (P.S.F.)
 INCLUDES DEAD AND CONSTRUCTION LOAD CARRIED
 BY METAL DECK *(NOT SHOWN IN TABLES)*
 LIMIT STATE DESIGN (LSD) - IMPERIAL UNITS

0.0476" Deck
0.787" Rebar

INPUT SECTION:

ITEM	DESCRIPTION OR SECTION PROPERTIES	CONCRETE COVER ABOVE TOP OF METAL DECK (hf) OR (hc) (IN)							
		2.50	3.00	3.50	4.00	4.50	5.00	5.50	6.00
A	METAL DECK THICK (INCH) (Td)	0.0476	0.0476	0.0476	0.0476	0.0476	0.0476	0.0476	0.0476
B	METAL DECK YIELD STRENGTH (KSI)(Fy)	40.6	40.6	40.6	40.6	40.6	40.6	40.6	40.6
C	METAL DECK EFF. (Ix) (IN ⁴)/FT	5.09	5.09	5.09	5.09	5.09	5.09	5.09	5.09
D	METAL DECK EFF. (Sx) (IN ³)/FT	1.15	1.15	1.15	1.15	1.15	1.15	1.15	1.15
E	METAL DECK (Es)(PSI)	2.95E+07	2.95E+07	2.95E+07	2.95E+07	2.95E+07	2.95E+07	2.95E+07	2.95E+07
F	# REINFORCING STEEL BAR DIA. (INCH)	0.787	0.787	0.787	0.787	0.787	0.787	0.787	0.787
G	CONCRETE STRENGTH (f'c) (PSI)	4350	4350	4350	4350	4350	4350	4350	4350
H	CONCRETE (Ec) (PSI)	3.80E+06	3.80E+06	3.80E+06	3.80E+06	3.80E+06	3.80E+06	3.80E+06	3.80E+06
I	A _F (IN ²)/FT	0.865	0.865	0.865	0.865	0.865	0.865	0.865	0.865
J	I _{x(F)} (IN ⁴)/FT	7.18	7.18	7.18	7.18	7.18	7.18	7.18	7.18
K	ALLOWABLE FORCE (LBS/FT)	659	659	659	659	659	659	659	659
L	FINAL EFF. CROSS SECT. AREA A _{EO} (IN ²)	0.672	0.672	0.672	0.672	0.672	0.672	0.672	0.672
M	DEFLECTION CRITERIA K _{1,2,3,4}	1.333	1.333	1.333	1.333	1.333	1.333	1.333	1.333
N	DEFLECTION CRITERIA *	L/480	L/480	L/480	L/480	L/480	L/480	L/480	L/480

* DEFLECTION CRITERIA: L/360 (K₁=1), L/480 (K₂=1.333), L/600 (K₃=1.670) OR L/720 (K₄=2.0)
 # REINFORCING BAR Fy0=58.0KSI

OUTPUT SECTION #1

ITEM	DESCRIPTION	CONCRETE COVER ABOVE TOP OF METAL DECK (hf) OR (hc) (IN)							
		2.50	3.00	3.50	4.00	4.50	5.00	5.50	6.00
O	MAX. UNSHORED SPAN (C.L.21PSF).FT.	14.13	13.04	12.10	11.29	10.59	9.96	9.41	8.91
P	MAX. UNSHORED SPAN (C.L.42PSF).FT.	10.27	9.75	9.55	9.22	8.74	8.31	7.92	7.57
Q	TOTAL DEAD LOAD (NO CONST.).PSF.	53.61	59.86	66.11	72.35	78.60	84.85	91.10	97.34
R	CONCRETE VOLUME. YD ³ /100FT ²	1.231	1.385	1.539	1.693	1.848	2.002	2.156	2.310

C.L. = CONSTRUCTION LOAD (PSF)

OUTPUT SECTION #2: PLOT DATA - AND INPUT SECTION AS SHOWN #

ITEM	DESCRIPTION	(hf) OR (hc) (IN)	# MAXIMUM SPECIFIED UNIFORMLY DISTRIBUTED LOAD (P.S.F)							
			85	90	100	110	120	130	140	145
1	ALLOW. SINGLE UNSUP. SPAN - FT.	2.50	25.61	25.13	24.26	23.50	22.83	22.23	21.69	21.44
2	ALLOW. SINGLE UNSUP. SPAN - FT.	3.00	25.99	25.59	24.85	24.17	23.54	22.96	22.42	22.16
3	ALLOW. SINGLE UNSUP. SPAN - FT.	3.50	26.06	25.68	24.96	24.31	23.70	23.13	22.61	22.36
4	ALLOW. SINGLE UNSUP. SPAN - FT.	4.00	26.11	25.75	25.07	24.43	23.84	23.30	22.79	22.54
5	ALLOW. SINGLE UNSUP. SPAN - FT.	4.50	26.17	25.82	25.16	24.55	23.98	23.45	22.95	22.71
6	ALLOW. SINGLE UNSUP. SPAN - FT.	5.00	26.22	25.88	25.25	24.66	24.10	23.59	23.10	22.87
7	ALLOW. SINGLE UNSUP. SPAN - FT.	5.50	26.26	25.94	25.33	24.75	24.22	23.72	23.25	23.02
8	ALLOW. SINGLE UNSUP. SPAN - FT.	6.00	26.31	25.99	25.40	24.85	24.33	23.84	23.38	23.16

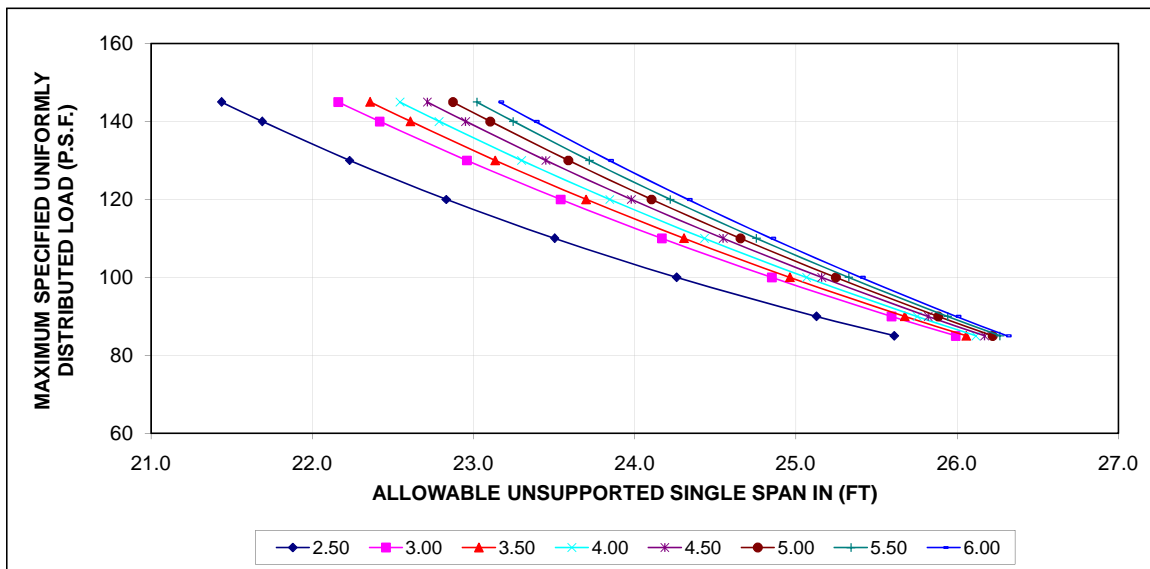



ULTRA-BOND COMPOSITE FLOOR DECK
 MAXIMUM SPECIFIED UNIFORMLY DISTRIBUTED LOAD (P.S.F)
 INCLUDES DEAD AND CONSTRUCTION LOAD CARRIED
 BY METAL DECK *(NOT SHOWN IN TABLES)*
 LIMIT STATE DESIGN (LSD) - **IMPERIAL UNITS**

0.0476" Deck
0.984" Rebar

INPUT SECTION:

ITEM	DESCRIPTION OR SECTION PROPERTIES	CONCRETE COVER ABOVE TOP OF METAL DECK (hf) OR (hc) (IN)							
		2.50	3.00	3.50	4.00	4.50	5.00	5.50	6.00
A	METAL DECK THICK (INCH) (Td)	0.0476	0.0476	0.0476	0.0476	0.0476	0.0476	0.0476	0.0476
B	METAL DECK YIELD STRENGTH (KSI)(Fy)	40.6	40.6	40.6	40.6	40.6	40.6	40.6	40.6
C	METAL DECK EFF. (Ix) (IN ⁴)/FT	5.09	5.09	5.09	5.09	5.09	5.09	5.09	5.09
D	METAL DECK EFF. (Sx) (IN ³)/FT	1.15	1.15	1.15	1.15	1.15	1.15	1.15	1.15
E	METAL DECK (Es)(PSI)	2.95E+07	2.95E+07	2.95E+07	2.95E+07	2.95E+07	2.95E+07	2.95E+07	2.95E+07
F	# REINFORCING STEEL BAR DIA. (INCH)	0.984	0.984	0.984	0.984	0.984	0.984	0.984	0.984
G	CONCRETE STRENGTH (f'c) (PSI)	4350	4350	4350	4350	4350	4350	4350	4350
H	CONCRETE (Ec) (PSI)	3.80E+06	3.80E+06	3.80E+06	3.80E+06	3.80E+06	3.80E+06	3.80E+06	3.80E+06
I	A _F (IN ²)/FT	0.865	0.865	0.865	0.865	0.865	0.865	0.865	0.865
J	I _{x(F)} (IN ⁴)/FT	7.18	7.18	7.18	7.18	7.18	7.18	7.18	7.18
K	ALLOWABLE FORCE (LBS/FT)	659	659	659	659	659	659	659	659
L	FINAL EFF. CROSS SECT. AREA A _{SO} (IN ²)	0.900	0.900	0.900	0.900	0.900	0.900	0.900	0.900
M	DEFLECTION CRITERIA K _{1,2,3,4}	1.333	1.333	1.333	1.333	1.333	1.333	1.333	1.333
N	DEFLECTION CRITERIA *	L/480	L/480	L/480	L/480	L/480	L/480	L/480	L/480

* DEFLECTION CRITERIA: L/360 (K₁=1), L/480 (K₂=1.333), L/600 (K₃=1.670) OR L/720 (K₄=2.0)
 # REINFORCING BAR Fy0=58.0KSI

OUTPUT SECTION #1

ITEM	DESCRIPTION	CONCRETE COVER ABOVE TOP OF METAL DECK (hf) OR (hc) (IN)							
		2.50	3.00	3.50	4.00	4.50	5.00	5.50	6.00
O	MAX. UNSHORED SPAN (C.L.21PSF).FT.	14.10	13.01	12.08	11.27	10.57	9.94	9.39	8.90
P	MAX. UNSHORED SPAN (C.L.42PSF).FT.	10.29	9.74	9.58	9.21	8.73	8.30	7.91	7.56
Q	TOTAL DEAD LOAD (NO CONST.)PSF.	53.79	60.04	66.29	72.54	78.78	85.03	91.28	97.53
R	CONCRETE VOLUME. YD ³ /100FT ²	1.224	1.378	1.532	1.686	1.841	1.995	2.149	2.303

C.L. = CONSTRUCTION LOAD (PSF)

OUTPUT SECTION #2: PLOT DATA - AND INPUT SECTION AS SHOWN #

ITEM	DESCRIPTION	(hf) OR (hc) (IN)	# MAXIMUM SPECIFIED UNIFORMLY DISTRIBUTED LOAD (P.S.F)							
			85	90	100	110	120	130	140	145
1	ALLOW. SINGLE UNSUP. SPAN - FT.	2.50	25.84	25.35	24.48	23.71	23.04	22.43	21.88	21.63
2	ALLOW. SINGLE UNSUP. SPAN - FT.	3.00	27.18	26.67	25.75	24.95	24.24	23.60	23.02	22.76
3	ALLOW. SINGLE UNSUP. SPAN - FT.	3.50	28.53	27.99	27.02	26.18	25.43	24.76	24.16	23.88
4	ALLOW. SINGLE UNSUP. SPAN - FT.	4.00	29.87	29.31	28.30	27.41	26.63	25.93	25.30	25.00
5	ALLOW. SINGLE UNSUP. SPAN - FT.	4.50	30.16	29.76	29.00	28.29	27.64	27.03	26.44	26.13
6	ALLOW. SINGLE UNSUP. SPAN - FT.	5.00	30.22	29.84	29.10	28.42	27.79	27.19	26.64	26.37
7	ALLOW. SINGLE UNSUP. SPAN - FT.	5.50	30.28	29.91	29.20	28.54	27.93	27.35	26.80	26.54
8	ALLOW. SINGLE UNSUP. SPAN - FT.	6.00	30.34	29.98	29.29	28.65	28.05	27.49	26.96	26.71

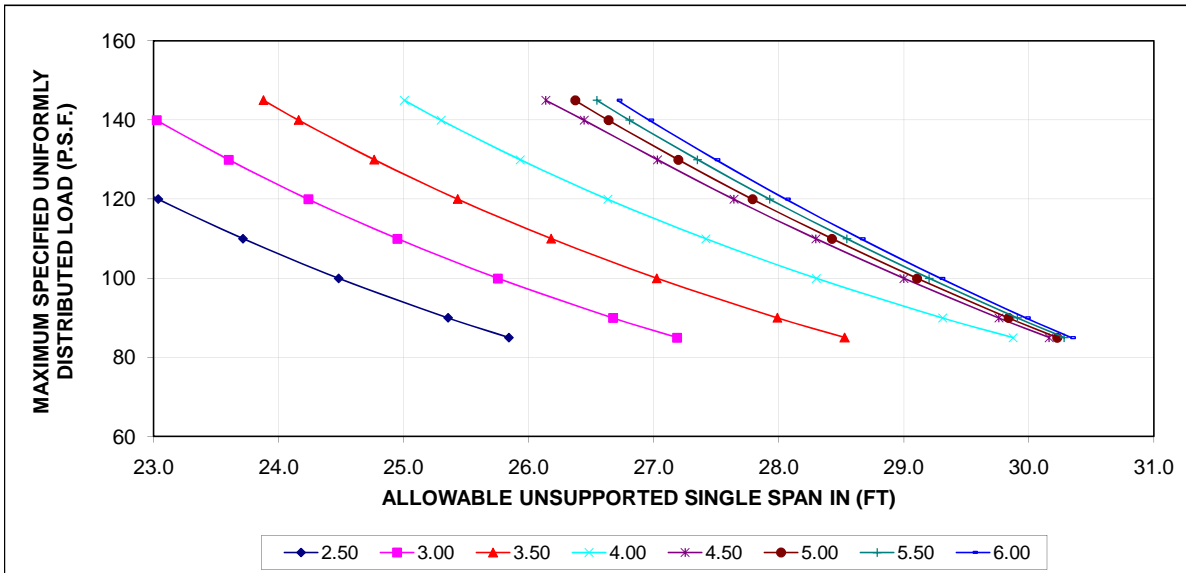



ULTRA-BOND COMPOSITE FLOOR DECK
 MAXIMUM SPECIFIED UNIFORMLY DISTRIBUTED LOAD (P.S.F)
 INCLUDES DEAD AND CONSTRUCTION LOAD CARRIED
 BY METAL DECK *(NOT SHOWN IN TABLES)*
 LIMIT STATE DESIGN (LSD) - IMPERIAL UNITS

0.0476" Deck
1.181" Rebar

INPUT SECTION:

ITEM	DESCRIPTION OR SECTION PROPERTIES	CONCRETE COVER ABOVE TOP OF METAL DECK (hf) OR (hc) (IN)							
		2.50	3.00	3.50	4.00	4.50	5.00	5.50	6.00
A	METAL DECK THICK (INCH) (Td)	0.0476	0.0476	0.0476	0.0476	0.0476	0.0476	0.0476	0.0476
B	METAL DECK YIELD STRENGTH (KSI)(Fy)	40.6	40.6	40.6	40.6	40.6	40.6	40.6	40.6
C	METAL DECK EFF. (Ix) (IN ⁴)/FT	5.09	5.09	5.09	5.09	5.09	5.09	5.09	5.09
D	METAL DECK EFF. (Sx) (IN ³)/FT	1.15	1.15	1.15	1.15	1.15	1.15	1.15	1.15
E	METAL DECK (Es)(PSI)	2.95E+07	2.95E+07	2.95E+07	2.95E+07	2.95E+07	2.95E+07	2.95E+07	2.95E+07
F	# REINFORCING STEEL BAR DIA. (INCH)	1.181	1.181	1.181	1.181	1.181	1.181	1.181	1.181
G	CONCRETE STRENGTH (f'c) (PSI)	4350	4350	4350	4350	4350	4350	4350	4350
H	CONCRETE (Ec) (PSI)	3.80E+06	3.80E+06	3.80E+06	3.80E+06	3.80E+06	3.80E+06	3.80E+06	3.80E+06
I	A _F (IN ²)/FT	0.865	0.865	0.865	0.865	0.865	0.865	0.865	0.865
J	I _{x(F)} (IN ⁴)/FT	7.18	7.18	7.18	7.18	7.18	7.18	7.18	7.18
K	ALLOWABLE FORCE (LBS/FT)	659	659	659	659	659	659	659	659
L	FINAL EFF. CROSS SECT. AREA A _{SO} (IN ²)	1.095	1.095	1.095	1.095	1.095	1.095	1.095	1.095
M	DEFLECTION CRITERIA K _{1,2,3,4}	1.333	1.333	1.333	1.333	1.333	1.333	1.333	1.333
N	DEFLECTION CRITERIA *	L/480	L/480	L/480	L/480	L/480	L/480	L/480	L/480

* DEFLECTION CRITERIA: L/360 (K₁=1), L/480 (K₂=1.333), L/600 (K₃=1.670) OR L/720 (K₄=2.0)
 # REINFORCING BAR Fy0=58.0KSI

OUTPUT SECTION #1

ITEM	DESCRIPTION	CONCRETE COVER ABOVE TOP OF METAL DECK (hf) OR (hc) (IN)							
		2.50	3.00	3.50	4.00	4.50	5.00	5.50	6.00
O	MAX. UNSHORED SPAN (C.L.21PSF).FT.	14.06	12.98	12.05	11.25	10.54	9.92	9.37	8.88
P	MAX. UNSHORED SPAN (C.L.42PSF).FT.	10.31	9.72	9.61	9.19	8.71	8.29	7.90	7.55
Q	TOTAL DEAD LOAD (NO CONST.)PSF.	54.01	60.26	66.51	72.76	79.00	85.25	91.50	97.75
R	CONCRETE VOLUME. YD ³ /100FT ²	1.215	1.369	1.524	1.678	1.832	1.986	2.141	2.295

C.L. = CONSTRUCTION LOAD (PSF)

OUTPUT SECTION #2: PLOT DATA - AND INPUT SECTION AS SHOWN #

ITEM	DESCRIPTION	(hf) OR (hc) (IN)	# MAXIMUM SPECIFIED UNIFORMLY DISTRIBUTED LOAD (P.S.F)							
			85	90	100	110	120	130	140	145
1	ALLOW. SINGLE UNSUP. SPAN - FT.	2.50	26.09	25.60	24.72	23.94	23.26	22.65	22.10	21.84
2	ALLOW. SINGLE UNSUP. SPAN - FT.	3.00	27.49	26.97	26.04	25.23	24.51	23.86	23.28	23.01
3	ALLOW. SINGLE UNSUP. SPAN - FT.	3.50	28.89	28.34	27.36	26.51	25.75	25.08	24.46	24.18
4	ALLOW. SINGLE UNSUP. SPAN - FT.	4.00	30.29	29.71	28.69	27.79	27.00	26.29	25.65	25.35
5	ALLOW. SINGLE UNSUP. SPAN - FT.	4.50	31.69	31.09	30.02	29.08	28.25	27.51	26.84	26.53
6	ALLOW. SINGLE UNSUP. SPAN - FT.	5.00	33.10	32.47	31.35	30.37	29.51	28.73	28.03	27.71
7	ALLOW. SINGLE UNSUP. SPAN - FT.	5.50	33.29	32.88	32.10	31.38	30.70	29.96	29.23	28.89
8	ALLOW. SINGLE UNSUP. SPAN - FT.	6.00	33.35	32.96	32.20	31.50	30.85	30.23	29.65	29.37

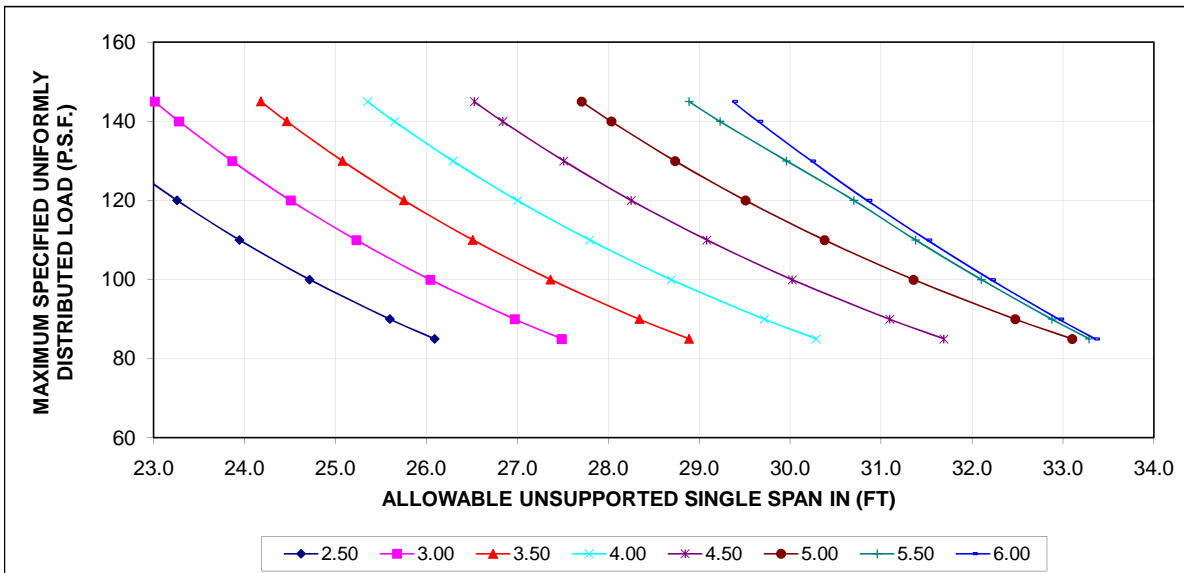



ULTRA-BOND COMPOSITE FLOOR DECK
 MAXIMUM SPECIFIED UNIFORMLY DISTRIBUTED LOAD (P.S.F)
 INCLUDES DEAD AND CONSTRUCTION LOAD CARRIED
 BY METAL DECK *(NOT SHOWN IN TABLES)*
 LIMIT STATE DESIGN (LSD) - IMPERIAL UNITS

0.0378" Deck
0.394" Rebar

INPUT SECTION:

ITEM	DESCRIPTION OR SECTION PROPERTIES	CONCRETE COVER ABOVE TOP OF METAL DECK (hf) OR (hc) (IN)							
		2.50	3.00	3.50	4.00	4.50	5.00	5.50	6.00
A	METAL DECK THICK (INCH) (Td)	0.0378	0.0378	0.0378	0.0378	0.0378	0.0378	0.0378	0.0378
B	METAL DECK YIELD STRENGTH (KSI)(Fy)	40.6	40.6	40.6	40.6	40.6	40.6	40.6	40.6
C	METAL DECK EFF. (Ix) (IN ⁴)/FT	3.37	3.37	3.37	3.37	3.37	3.37	3.37	3.37
D	METAL DECK EFF. (Sx) (IN ³)/FT	0.684	0.684	0.684	0.684	0.684	0.684	0.684	0.684
E	METAL DECK (Es)(PSI)	2.95E+07	2.95E+07	2.95E+07	2.95E+07	2.95E+07	2.95E+07	2.95E+07	2.95E+07
F	# REINFORCING STEEL BAR DIA. (INCH)	0.394	0.394	0.394	0.394	0.394	0.394	0.394	0.394
G	CONCRETE STRENGTH (f'c) (PSI)	4350	4350	4350	4350	4350	4350	4350	4350
H	CONCRETE (Ec) (PSI)	3.80E+06	3.80E+06	3.80E+06	3.80E+06	3.80E+06	3.80E+06	3.80E+06	3.80E+06
I	A _F (IN ²)/FT	0.687	0.687	0.687	0.687	0.687	0.687	0.687	0.687
J	I _{X(F)} (IN ⁴)/FT	5.70	5.70	5.70	5.70	5.70	5.70	5.70	5.70
K	ALLOWABLE FORCE (LBS/FT)	437	437	437	437	437	437	437	437
L	FINAL EFF. CROSS SECT. AREA A _{SO} (IN ²)	0.372	0.372	0.372	0.372	0.372	0.372	0.372	0.372
M	DEFLECTION CRITERIA K _{1,2,3,4}	1.000	1.000	1.000	1.000	1.000	1.000	1.000	1.000

* DEFLECTION CRITERIA: L/360 (K₁=1), L/480 (K₂=1.333), L/600 (K₃=1.670) OR L/720 (K₄=2.0)
 # REINFORCING BAR Fy0=58.0KSI

OUTPUT SECTION #1

ITEM	DESCRIPTION	CONCRETE COVER ABOVE TOP OF METAL DECK (hf) OR (hc) (IN)							
		2.50	3.00	3.50	4.00	4.50	5.00	5.50	6.00
O	MAX. UNSHORED SPAN (C.L.21PSF).FT.	9.48	8.74	8.11	7.56	7.08	6.66	6.28	5.95
P	MAX. UNSHORED SPAN (C.L.42PSF).FT.	7.38	6.92	6.52	6.16	5.84	5.55	5.29	5.05
Q	TOTAL DEAD LOAD (NO CONST.).PSF.	52.77	59.01	65.26	71.51	77.76	84.00	90.25	96.50
R	CONCRETE VOLUME. YD ³ /100FT ²	1.240	1.394	1.549	1.703	1.857	2.011	2.166	2.320

C.L. = CONSTRUCTION LOAD (PSF)

OUTPUT SECTION #2: PLOT DATA - AND INPUT SECTION AS SHOWN #

ITEM	DESCRIPTION	(hf) OR (hc) (IN)	# MAXIMUM SPECIFIED UNIFORMLY DISTRIBUTED LOAD (P.S.F)							
			85	90	100	110	120	130	140	145
1	ALLOW. SINGLE UNSUP. SPAN - FT.	2.50	19.47	19.16	18.57	18.03	17.54	17.09	16.67	16.47
2	ALLOW. SINGLE UNSUP. SPAN - FT.	3.00	19.51	19.21	18.65	18.14	17.66	17.23	16.82	16.62
3	ALLOW. SINGLE UNSUP. SPAN - FT.	3.50	19.55	19.27	18.73	18.23	17.78	17.35	16.95	16.77
4	ALLOW. SINGLE UNSUP. SPAN - FT.	4.00	19.59	19.32	18.80	18.32	17.88	17.47	17.08	16.90
5	ALLOW. SINGLE UNSUP. SPAN - FT.	4.50	19.62	19.36	18.86	18.40	17.97	17.57	17.20	17.02
6	ALLOW. SINGLE UNSUP. SPAN - FT.	5.00	19.66	19.40	18.92	18.48	18.06	17.67	17.31	17.14
7	ALLOW. SINGLE UNSUP. SPAN - FT.	5.50	19.68	19.44	18.98	18.55	18.14	17.77	17.41	17.24
8	ALLOW. SINGLE UNSUP. SPAN - FT.	6.00	19.71	19.47	19.03	18.61	18.22	17.85	17.51	17.34

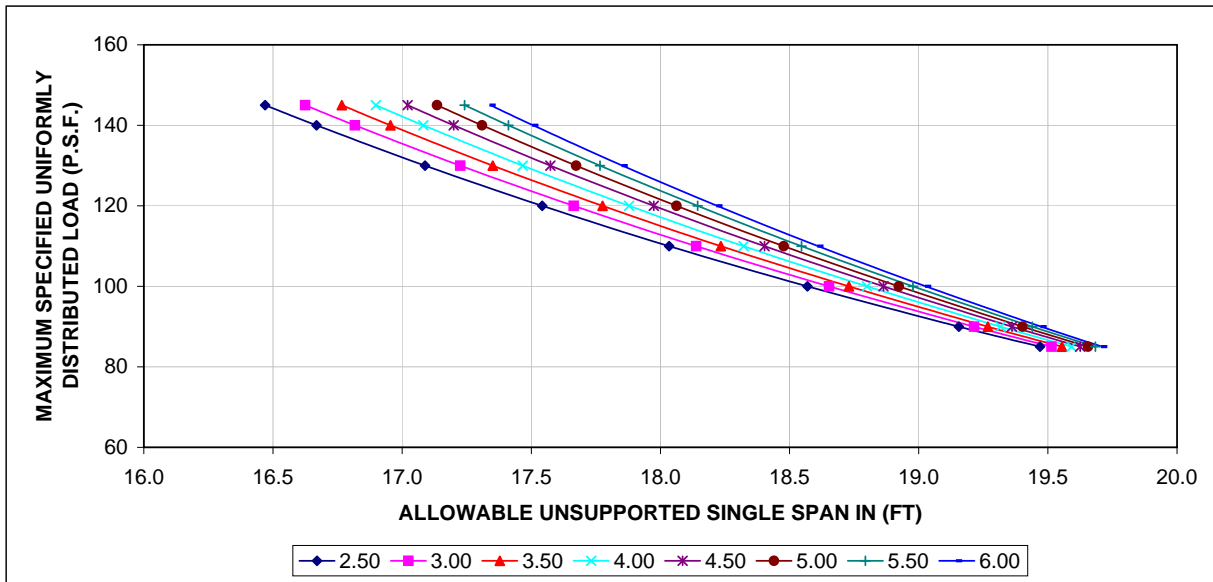



ULTRA-BOND COMPOSITE FLOOR DECK
 MAXIMUM SPECIFIED UNIFORMLY DISTRIBUTED LOAD (P.S.F)
 INCLUDES DEAD AND CONSTRUCTION LOAD CARRIED
 BY METAL DECK *(NOT SHOWN IN TABLES)*
 LIMIT STATE DESIGN (LSD) - IMPERIAL UNITS

0.0378" Deck
0.591" Rebar

INPUT SECTION:

ITEM	DESCRIPTION OR SECTION PROPERTIES	CONCRETE COVER ABOVE TOP OF METAL DECK (hf) OR (hc) (IN)							
		2.50	3.00	3.50	4.00	4.50	5.00	5.50	6.00
A	METAL DECK THICK (INCH) (Td)	0.0378	0.0378	0.0378	0.0378	0.0378	0.0378	0.0378	0.0378
B	METAL DECK YIELD STRENGTH (KSI)(Fy)	40.6	40.6	40.6	40.6	40.6	40.6	40.6	40.6
C	METAL DECK EFF. (Ix) (IN ⁴)/FT	3.37	3.37	3.37	3.37	3.37	3.37	3.37	3.37
D	METAL DECK EFF. (Sx) (IN ³)/FT	0.684	0.684	0.684	0.684	0.684	0.684	0.684	0.684
E	METAL DECK (Es)(PSI)	2.95E+07	2.95E+07	2.95E+07	2.95E+07	2.95E+07	2.95E+07	2.95E+07	2.95E+07
F	# REINFORCING STEEL BAR DIA. (INCH)	0.591	0.591	0.591	0.591	0.591	0.591	0.591	0.591
G	CONCRETE STRENGTH (f'c) (PSI)	4350	4350	4350	4350	4350	4350	4350	4350
H	CONCRETE (Ec) (PSI)	3.80E+06	3.80E+06	3.80E+06	3.80E+06	3.80E+06	3.80E+06	3.80E+06	3.80E+06
I	A _F (IN ²)/FT	0.687	0.687	0.687	0.687	0.687	0.687	0.687	0.687
J	I _{X(F)} (IN ⁴)/FT	5.70	5.70	5.70	5.70	5.70	5.70	5.70	5.70
K	ALLOWABLE FORCE (LBS/FT)	437	437	437	437	437	437	437	437
L	FINAL EFF. CROSS SECT. AREA A _{SO} (IN ²)	0.500	0.500	0.500	0.500	0.500	0.500	0.500	0.500
M	DEFLECTION CRITERIA K _{1,2,3,4}	1.000	1.000	1.000	1.000	1.000	1.000	1.000	1.000

* DEFLECTION CRITERIA: L/360 (K₁=1), L/480 (K₂=1.333), L/600 (K₃=1.670) OR L/720 (K₄=2.0)
 # REINFORCING BAR Fy0=58.0KSI

OUTPUT SECTION #1

ITEM	DESCRIPTION	CONCRETE COVER ABOVE TOP OF METAL DECK (hf) OR (hc) (IN)							
		2.50	3.00	3.50	4.00	4.50	5.00	5.50	6.00
O	MAX. UNSHORED SPAN (C.L.21PSF).FT.	9.47	8.73	8.10	7.55	7.07	6.65	6.28	5.95
P	MAX. UNSHORED SPAN (C.L.42PSF).FT.	7.37	6.92	6.51	6.15	5.83	5.54	5.28	5.04
Q	TOTAL DEAD LOAD (NO CONST.).PSF.	52.87	59.11	65.36	71.61	77.86	84.10	90.35	96.60
R	CONCRETE VOLUME. YD ³ /100FT ²	1.236	1.390	1.545	1.699	1.853	2.007	2.162	2.316

C.L. = CONSTRUCTION LOAD (PSF)

OUTPUT SECTION #2: PLOT DATA - AND INPUT SECTION AS SHOWN #

ITEM	DESCRIPTION	(hf) OR (hc) (IN)	# MAXIMUM SPECIFIED UNIFORMLY DISTRIBUTED LOAD (P.S.F)							
			85	90	100	110	120	130	140	145
1	ALLOW. SINGLE UNSUP. SPAN - FT.	2.50	22.51	22.15	21.47	20.85	20.28	19.76	19.27	19.04
2	ALLOW. SINGLE UNSUP. SPAN - FT.	3.00	22.56	22.22	21.57	20.97	20.43	19.92	19.45	19.22
3	ALLOW. SINGLE UNSUP. SPAN - FT.	3.50	22.61	22.28	21.66	21.09	20.56	20.07	19.61	19.39
4	ALLOW. SINGLE UNSUP. SPAN - FT.	4.00	22.66	22.34	21.74	21.19	20.68	20.20	19.76	19.55
5	ALLOW. SINGLE UNSUP. SPAN - FT.	4.50	22.70	22.40	21.82	21.29	20.79	20.33	19.90	19.69
6	ALLOW. SINGLE UNSUP. SPAN - FT.	5.00	22.74	22.44	21.89	21.38	20.90	20.45	20.03	19.82
7	ALLOW. SINGLE UNSUP. SPAN - FT.	5.50	22.77	22.49	21.96	21.46	20.99	20.56	20.15	19.95
8	ALLOW. SINGLE UNSUP. SPAN - FT.	6.00	22.80	22.53	22.02	21.53	21.08	20.66	20.26	20.07

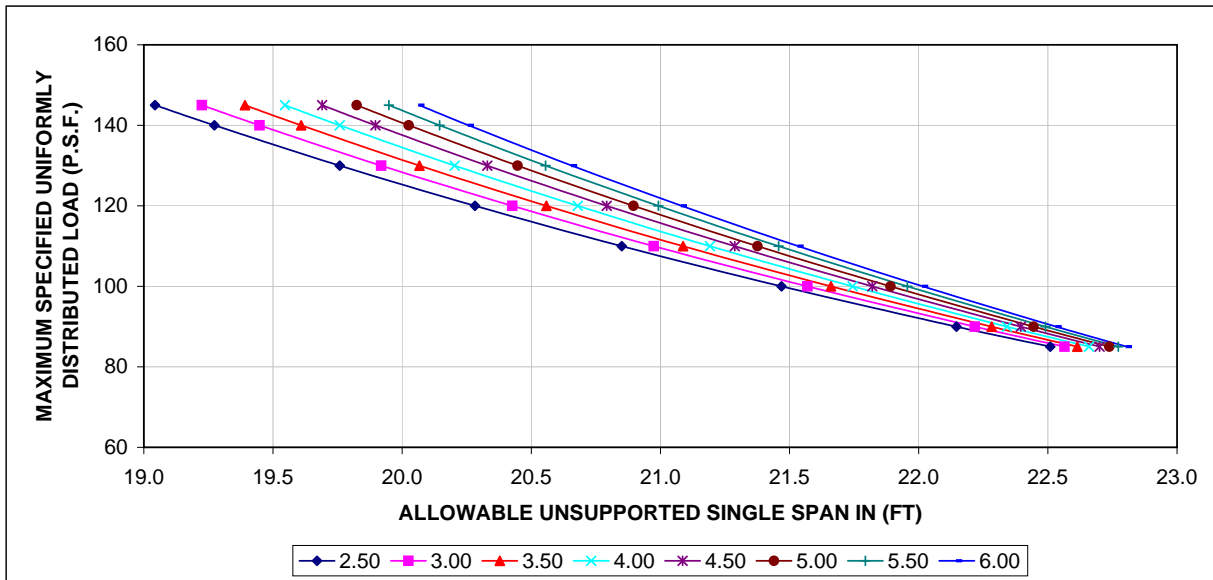



ULTRA-BOND COMPOSITE FLOOR DECK
 MAXIMUM SPECIFIED UNIFORMLY DISTRIBUTED LOAD (P.S.F)
 INCLUDES DEAD AND CONSTRUCTION LOAD CARRIED
 BY METAL DECK *(NOT SHOWN IN TABLES)*
 LIMIT STATE DESIGN (LSD) - IMPERIAL UNITS

0.0378" Deck
0.787" Rebar

INPUT SECTION:

ITEM	DESCRIPTION OR SECTION PROPERTIES	CONCRETE COVER ABOVE TOP OF METAL DECK (hf) OR (hc) (IN)							
		2.50	3.00	3.50	4.00	4.50	5.00	5.50	6.00
A	METAL DECK THICK (INCH) (Td)	0.0378	0.0378	0.0378	0.0378	0.0378	0.0378	0.0378	0.0378
B	METAL DECK YIELD STRENGTH (KSI)(Fy)	40.6	40.6	40.6	40.6	40.6	40.6	40.6	40.6
C	METAL DECK EFF. (Ix) (IN ⁴)/FT	3.37	3.37	3.37	3.37	3.37	3.37	3.37	3.37
D	METAL DECK EFF. (Sx) (IN ³)/FT	0.684	0.684	0.684	0.684	0.684	0.684	0.684	0.684
E	METAL DECK (Es)(PSI)	2.95E+07	2.95E+07	2.95E+07	2.95E+07	2.95E+07	2.95E+07	2.95E+07	2.95E+07
F	# REINFORCING STEEL BAR DIA. (INCH)	0.787	0.787	0.787	0.787	0.787	0.787	0.787	0.787
G	CONCRETE STRENGTH (f'c) (PSI)	4350	4350	4350	4350	4350	4350	4350	4350
H	CONCRETE (Ec) (PSI)	3.80E+06	3.80E+06	3.80E+06	3.80E+06	3.80E+06	3.80E+06	3.80E+06	3.80E+06
I	A _F (IN ²)/FT	0.687	0.687	0.687	0.687	0.687	0.687	0.687	0.687
J	I _{X(F)} (IN ⁴)/FT	5.70	5.70	5.70	5.70	5.70	5.70	5.70	5.70
K	ALLOWABLE FORCE (LBS/FT)	437	437	437	437	437	437	437	437
L	FINAL EFF. CROSS SECT. AREA A _{SO} (IN ²)	0.560	0.560	0.560	0.560	0.560	0.560	0.560	0.560
M	DEFLECTION CRITERIA K _{1,2,3,4}	1.000	1.000	1.000	1.000	1.000	1.000	1.000	1.000

* DEFLECTION CRITERIA: L/360 (K₁=1), L/480 (K₂=1.333), L/600 (K₃=1.670) OR L/720 (K₄=2.0)
 # REINFORCING BAR Fy0=58.0KSI

OUTPUT SECTION #1

ITEM	DESCRIPTION	CONCRETE COVER ABOVE TOP OF METAL DECK (hf) OR (hc) (IN)							
		2.50	3.00	3.50	4.00	4.50	5.00	5.50	6.00
O	MAX. UNSHORED SPAN (C.L.21PSF).FT.	9.45	8.71	8.08	7.54	7.06	6.64	6.27	5.94
P	MAX. UNSHORED SPAN (C.L.42PSF).FT.	7.36	6.91	6.50	6.15	5.83	5.54	5.28	5.04
Q	TOTAL DEAD LOAD (NO CONST.).PSF.	53.01	59.25	65.50	71.75	78.00	84.24	90.49	96.74
R	CONCRETE VOLUME. YD ³ /100FT ²	1.231	1.385	1.539	1.693	1.848	2.002	2.156	2.310

C.L. = CONSTRUCTION LOAD (PSF)

OUTPUT SECTION #2: PLOT DATA - AND INPUT SECTION AS SHOWN #

ITEM	DESCRIPTION	(hf) OR (hc) (IN)	# MAXIMUM SPECIFIED UNIFORMLY DISTRIBUTED LOAD (P.S.F)							
			85	90	100	110	120	130	140	145
1	ALLOW. SINGLE UNSUP. SPAN - FT.	2.50	23.78	23.40	22.68	22.03	21.43	20.88	20.37	20.12
2	ALLOW. SINGLE UNSUP. SPAN - FT.	3.00	23.84	23.48	22.79	22.16	21.58	21.05	20.55	20.32
3	ALLOW. SINGLE UNSUP. SPAN - FT.	3.50	23.90	23.55	22.89	22.28	21.73	21.21	20.72	20.49
4	ALLOW. SINGLE UNSUP. SPAN - FT.	4.00	23.95	23.61	22.98	22.40	21.86	21.35	20.88	20.66
5	ALLOW. SINGLE UNSUP. SPAN - FT.	4.50	23.99	23.67	23.06	22.50	21.98	21.49	21.03	20.81
6	ALLOW. SINGLE UNSUP. SPAN - FT.	5.00	24.03	23.72	23.14	22.59	22.09	21.61	21.17	20.95
7	ALLOW. SINGLE UNSUP. SPAN - FT.	5.50	24.07	23.77	23.21	22.68	22.19	21.73	21.29	21.09
8	ALLOW. SINGLE UNSUP. SPAN - FT.	6.00	24.10	23.82	23.27	22.76	22.29	21.84	21.41	21.21

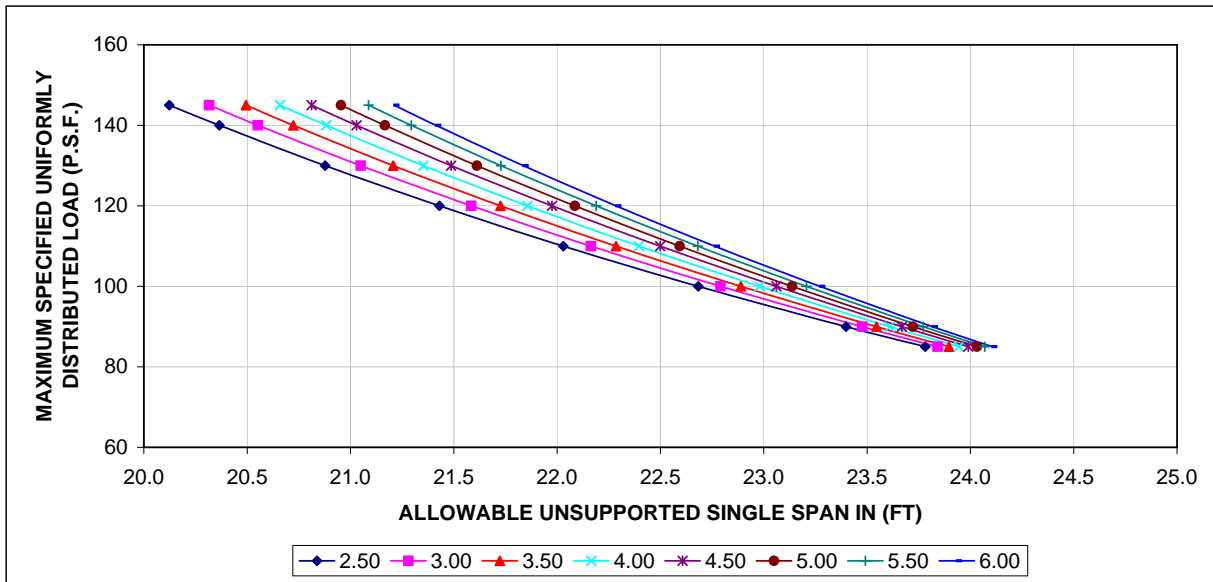



ULTRA-BOND COMPOSITE FLOOR DECK
 MAXIMUM SPECIFIED UNIFORMLY DISTRIBUTED LOAD (P.S.F)
 INCLUDES DEAD AND CONSTRUCTION LOAD CARRIED
 BY METAL DECK *(NOT SHOWN IN TABLES)*
 LIMIT STATE DESIGN (LSD) - **IMPERIAL UNITS**

0.0378" Deck
0.984" Rebar

INPUT SECTION:

ITEM	DESCRIPTION OR SECTION PROPERTIES	CONCRETE COVER ABOVE TOP OF METAL DECK (hf) OR (hc) (IN)							
		2.50	3.00	3.50	4.00	4.50	5.00	5.50	6.00
A	METAL DECK THICK (INCH) (Td)	0.0378	0.0378	0.0378	0.0378	0.0378	0.0378	0.0378	0.0378
B	METAL DECK YIELD STRENGTH (KSI)(Fy)	40.6	40.6	40.6	40.6	40.6	40.6	40.6	40.6
C	METAL DECK EFF. (Ix) (IN ⁴)/FT	3.37	3.37	3.37	3.37	3.37	3.37	3.37	3.37
D	METAL DECK EFF. (Sx) (IN ³)/FT	0.684	0.684	0.684	0.684	0.684	0.684	0.684	0.684
E	METAL DECK (Es)(PSI)	2.95E+07	2.95E+07	2.95E+07	2.95E+07	2.95E+07	2.95E+07	2.95E+07	2.95E+07
F	# REINFORCING STEEL BAR DIA. (INCH)	0.984	0.984	0.984	0.984	0.984	0.984	0.984	0.984
G	CONCRETE STRENGTH (f'c) (PSI)	4350	4350	4350	4350	4350	4350	4350	4350
H	CONCRETE (Ec) (PSI)	3.80E+06	3.80E+06	3.80E+06	3.80E+06	3.80E+06	3.80E+06	3.80E+06	3.80E+06
I	A _F (IN ²)/FT	0.687	0.687	0.687	0.687	0.687	0.687	0.687	0.687
J	I _{X(F)} (IN ⁴)/FT	5.70	5.70	5.70	5.70	5.70	5.70	5.70	5.70
K	ALLOWABLE FORCE (LBS/FT)	437	437	437	437	437	437	437	437
L	FINAL EFF. CROSS SECT. AREA A _{SO} (IN ²)	0.760	0.760	0.760	0.760	0.760	0.760	0.760	0.760
M	DEFLECTION CRITERIA K _{1,2,3,4}	1.000	1.000	1.000	1.000	1.000	1.000	1.000	1.000

* DEFLECTION CRITERIA: L/360 (K₁=1), L/480 (K₂=1.333), L/600 (K₃=1.670) OR L/720 (K₄=2.0)
 # REINFORCING BAR Fy0=58.0KSI

OUTPUT SECTION #1

ITEM	DESCRIPTION	CONCRETE COVER ABOVE TOP OF METAL DECK (hf) OR (hc) (IN)							
		2.50	3.00	3.50	4.00	4.50	5.00	5.50	6.00
O	MAX. UNSHORED SPAN (C.L.21PSF).FT.	9.42	8.69	8.07	7.52	7.05	6.63	6.26	5.93
P	MAX. UNSHORED SPAN (C.L.42PSF).FT.	7.35	6.89	6.49	6.14	5.82	5.53	5.27	5.03
Q	TOTAL DEAD LOAD (NO CONST.).PSF.	53.19	59.43	65.68	71.93	78.18	84.42	90.67	96.92
R	CONCRETE VOLUME. YD ³ /100FT ²	1.224	1.378	1.532	1.686	1.841	1.995	2.149	2.303

C.L. = CONSTRUCTION LOAD (PSF)

OUTPUT SECTION #2: PLOT DATA - AND INPUT SECTION AS SHOWN #

ITEM	DESCRIPTION	(hf) OR (hc) (IN)	# MAXIMUM SPECIFIED UNIFORMLY DISTRIBUTED LOAD (P.S.F)							
			85	90	100	110	120	130	140	145
1	ALLOW. SINGLE UNSUP. SPAN - FT.	2.50	27.58	27.14	26.31	25.55	24.86	24.22	23.62	23.34
2	ALLOW. SINGLE UNSUP. SPAN - FT.	3.00	27.66	27.23	26.44	25.71	25.04	24.42	23.85	23.57
3	ALLOW. SINGLE UNSUP. SPAN - FT.	3.50	27.73	27.32	26.56	25.86	25.21	24.61	24.05	23.78
4	ALLOW. SINGLE UNSUP. SPAN - FT.	4.00	27.79	27.40	26.67	25.99	25.37	24.78	24.24	23.98
5	ALLOW. SINGLE UNSUP. SPAN - FT.	4.50	27.85	27.47	26.77	26.12	25.51	24.94	24.41	24.16
6	ALLOW. SINGLE UNSUP. SPAN - FT.	5.00	27.90	27.54	26.86	26.23	25.64	25.09	24.58	24.33
7	ALLOW. SINGLE UNSUP. SPAN - FT.	5.50	27.95	27.60	26.95	26.34	25.77	25.23	24.73	24.49
8	ALLOW. SINGLE UNSUP. SPAN - FT.	6.00	27.99	27.66	27.02	26.43	25.88	25.36	24.87	24.63

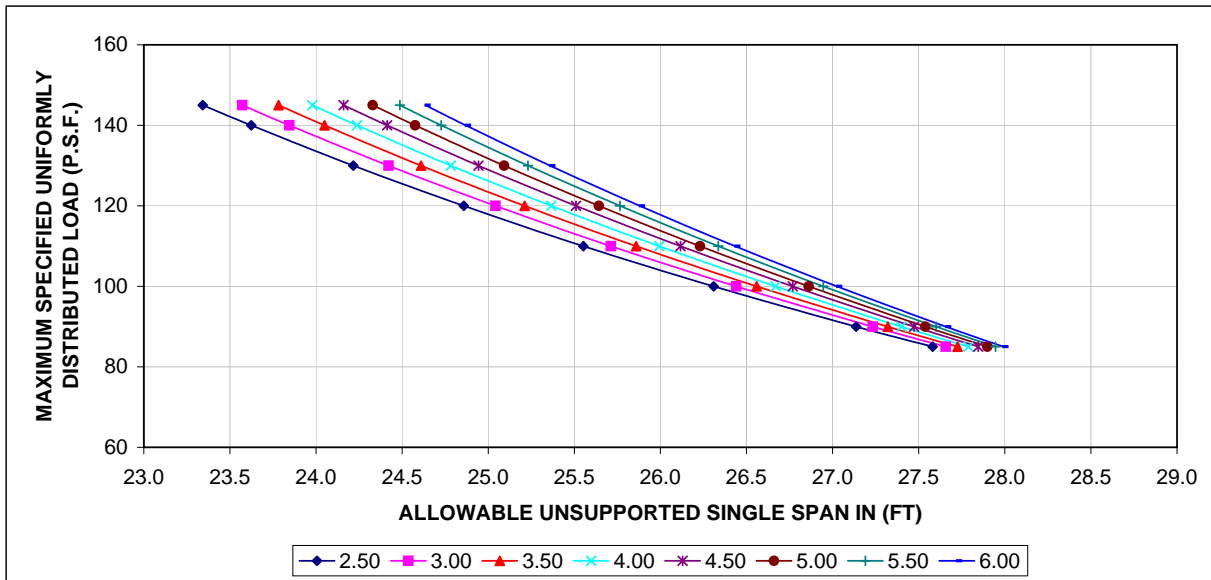



ULTRA-BOND COMPOSITE FLOOR DECK
 MAXIMUM SPECIFIED UNIFORMLY DISTRIBUTED LOAD (P.S.F)
 INCLUDES DEAD AND CONSTRUCTION LOAD CARRIED
 BY METAL DECK *(NOT SHOWN IN TABLES)*
 LIMIT STATE DESIGN (LSD) - **IMPERIAL UNITS**

0.0378" Deck
0.1.181" Rebar

INPUT SECTION:

ITEM	DESCRIPTION OR SECTION PROPERTIES	CONCRETE COVER ABOVE TOP OF METAL DECK (hf) OR (hc) (IN)							
		2.50	3.00	3.50	4.00	4.50	5.00	5.50	6.00
A	METAL DECK THICK (INCH) (Td)	0.0378	0.0378	0.0378	0.0378	0.0378	0.0378	0.0378	0.0378
B	METAL DECK YIELD STRENGTH (KSI)(Fy)	40.6	40.6	40.6	40.6	40.6	40.6	40.6	40.6
C	METAL DECK EFF. (Ix) (IN ⁴)/FT	3.37	3.37	3.37	3.37	3.37	3.37	3.37	3.37
D	METAL DECK EFF. (Sx) (IN ³)/FT	0.684	0.684	0.684	0.684	0.684	0.684	0.684	0.684
E	METAL DECK (Es)(PSI)	2.95E+07	2.95E+07	2.95E+07	2.95E+07	2.95E+07	2.95E+07	2.95E+07	2.95E+07
F	# REINFORCING STEEL BAR DIA. (INCH)	1.181	1.181	1.181	1.181	1.181	1.181	1.181	1.181
G	CONCRETE STRENGTH (f'c) (PSI)	4350	4350	4350	4350	4350	4350	4350	4350
H	CONCRETE (Ec) (PSI)	3.80E+06	3.80E+06	3.80E+06	3.80E+06	3.80E+06	3.80E+06	3.80E+06	3.80E+06
I	A _F (IN ²)/FT	0.687	0.687	0.687	0.687	0.687	0.687	0.687	0.687
J	I _{X(F)} (IN ⁴)/FT	5.70	5.70	5.70	5.70	5.70	5.70	5.70	5.70
K	ALLOWABLE FORCE (LBS/FT)	437	437	437	437	437	437	437	437
L	FINAL EFF. CROSS SECT. AREA A _{SO} (IN ²)	1.095	1.095	1.095	1.095	1.095	1.095	1.095	1.095
M	DEFLECTION CRITERIA K _{1,2,3,4}	1.000	1.000	1.000	1.000	1.000	1.000	1.000	1.000

* DEFLECTION CRITERIA: L/360 (K₁=1), L/480 (K₂=1.333), L/600 (K₃=1.670) OR L/720 (K₄=2.0)
 # REINFORCING BAR Fy0=58.0KSI

OUTPUT SECTION #1

ITEM	DESCRIPTION	CONCRETE COVER ABOVE TOP OF METAL DECK (hf) OR (hc) (IN)							
		2.50	3.00	3.50	4.00	4.50	5.00	5.50	6.00
O	MAX. UNSHORED SPAN (C.L.21PSF).FT.	9.40	8.67	8.05	7.51	7.03	6.62	6.25	5.92
P	MAX. UNSHORED SPAN (C.L.42PSF).FT.	7.33	6.88	6.48	6.13	5.81	5.52	5.26	5.03
Q	TOTAL DEAD LOAD (NO CONST.).PSF.	53.41	59.66	65.90	72.15	78.40	84.65	90.89	97.14
R	CONCRETE VOLUME. YD ³ /100FT ²	1.215	1.369	1.524	1.678	1.832	1.986	2.141	2.295

C.L. = CONSTRUCTION LOAD (PSF)

OUTPUT SECTION #2: PLOT DATA - AND INPUT SECTION AS SHOWN #

ITEM	DESCRIPTION	(hf) OR (hc) (IN)	# MAXIMUM SPECIFIED UNIFORMLY DISTRIBUTED LOAD (P.S.F)							
			85	90	100	110	120	130	140	145
1	ALLOW. SINGLE UNSUP. SPAN - FT.	2.50	28.26	27.73	26.77	25.93	25.19	24.53	23.93	23.65
2	ALLOW. SINGLE UNSUP. SPAN - FT.	3.00	29.80	29.24	28.23	27.35	26.56	25.87	25.24	24.94
3	ALLOW. SINGLE UNSUP. SPAN - FT.	3.50	31.33	30.74	29.68	28.75	27.93	27.20	26.53	26.23
4	ALLOW. SINGLE UNSUP. SPAN - FT.	4.00	32.86	32.24	31.13	30.16	29.30	28.53	27.83	27.51
5	ALLOW. SINGLE UNSUP. SPAN - FT.	4.50	33.23	32.78	31.94	31.17	30.44	29.77	29.13	28.79
6	ALLOW. SINGLE UNSUP. SPAN - FT.	5.00	33.30	32.87	32.06	31.31	30.61	29.95	29.34	29.04
7	ALLOW. SINGLE UNSUP. SPAN - FT.	5.50	33.36	32.95	32.17	31.44	30.76	30.13	29.53	29.24
8	ALLOW. SINGLE UNSUP. SPAN - FT.	6.00	33.42	33.03	32.27	31.57	30.91	30.29	29.70	29.42

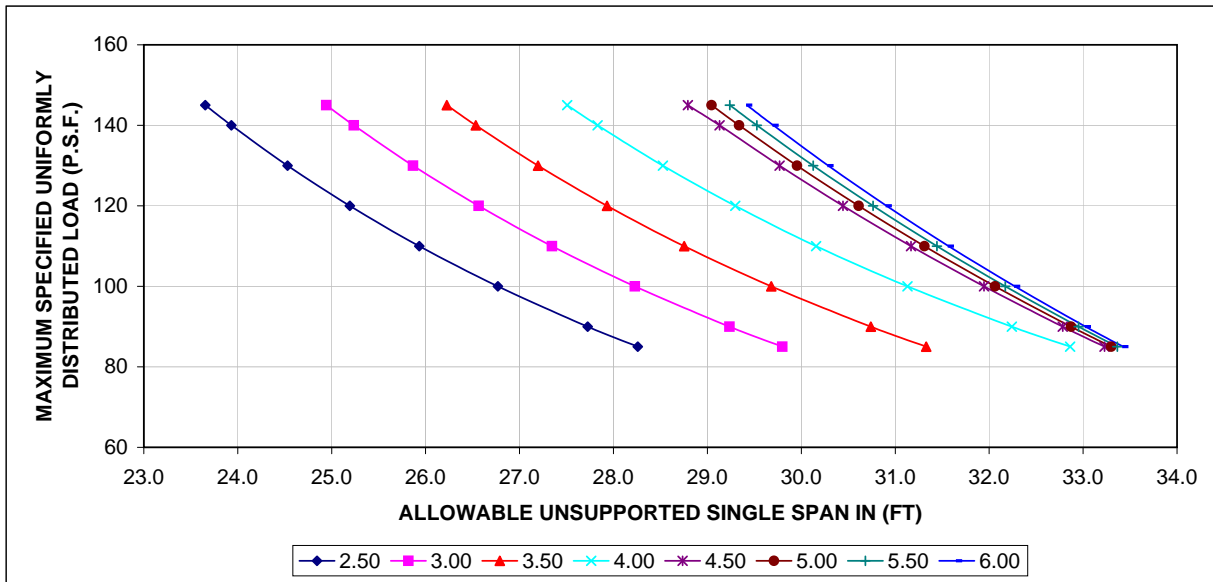



ULTRA-BOND COMPOSITE FLOOR DECK
 MAXIMUM SPECIFIED UNIFORMLY DISTRIBUTED LOAD (KPa)
 INCLUDES DEAD AND CONSTRUCTION LOAD CARRIED
 BY METAL DECK *(NOT SHOWN IN TABLES)*
 LIMIT STATE DESIGN (LSD) -METRIC UNITS

1.21 mm Deck
10 mm Rebar

INPUT SECTION:

ITEM	DESCRIPTION OR SECTION PROPERTIES	CONCRETE COVER ABOVE TOP OF METAL DECK (hf) OR (hc) (mm)							
		63.50	76.20	88.90	101.60	114.30	127.00	139.70	152.40
A	METAL DECK THICK (mm) (Td)	1.21	1.21	1.21	1.21	1.21	1.21	1.21	1.21
B	METAL DECK YIELD STRENGTH (KPa)(Fy)	280	280	280	280	280	280	280	280
C	METAL DECK EFF. (I _x) (mm ⁴)/m	6.95E+06	6.95E+06	6.95E+06	6.95E+06	6.95E+06	6.95E+06	6.95E+06	6.95E+06
D	METAL DECK EFF. (S _x) (mm ³)/m	6.18E+04	6.18E+04	6.18E+04	6.18E+04	6.18E+04	6.18E+04	6.18E+04	6.18E+04
E	METAL DECK (E _s)(KPa)	2.03E+08	2.03E+08	2.03E+08	2.03E+08	2.03E+08	2.03E+08	2.03E+08	2.03E+08
F	# REINFORCING STEEL BAR DIA. (mm)	10	10	10	10	10	10	10	10
G	CONCRETE STRENGTH (f _c) (KPa)	3.00E+04	3.00E+04	3.00E+04	3.00E+04	3.00E+04	3.00E+04	3.00E+04	3.00E+04
H	CONCRETE (E _c) (KPa)	2.62E+07	2.62E+07	2.62E+07	2.62E+07	2.62E+07	2.62E+07	2.62E+07	2.62E+07
I	A _F (mm ²)/m	1830.917	1830.917	1830.917	1830.917	1830.917	1830.917	1830.917	1830.917
J	I _{x(F)} (mm ⁴)/m	9.80E+06	9.80E+06	9.80E+06	9.80E+06	9.80E+06	9.80E+06	9.80E+06	9.80E+06
K	ALLOWABLE FORCE (KN/m)	9.617	9.617	9.617	9.617	9.617	9.617	9.617	9.617
L	FINAL EFF. CROSS SECT. AREA A _{EO} (IN ²)	301	301	301	301	301	301	301	301
M	DEFLECTION CRITERIA K _{1,2,3,4}	1.333	1.333	1.333	1.333	1.333	1.333	1.333	1.333
N	DEFLECTION CRITERIA *	L/480	L/480	L/480	L/480	L/480	L/480	L/480	L/480

* DEFLECTION CRITERIA: L/360 (K₁=1), L/480 (K₂=1.333), L/600 (K₃=1.670) OR L/720 (K₄=2.0)
 # REINFORCING BAR Fy0=400MPa

OUTPUT SECTION #1

ITEM	DESCRIPTION	CONCRETE COVER ABOVE TOP OF METAL DECK (hf) OR (hc) (mm)							
		63.50	76.20	88.90	101.60	114.30	127.00	139.70	152.40
O	MAX. UNSHORED SPAN (C.L.1.006KPa).m.	4.32	3.99	3.70	3.45	3.23	3.04	2.87	2.72
P	MAX. UNSHORED SPAN (C.L.2.011KPa).m.	3.12	2.98	2.90	2.82	2.67	2.54	2.42	2.31
Q	TOTAL DEAD LOAD (NO CONST.)KPa.	2.555	2.855	3.154	3.453	3.752	4.051	4.350	4.649
R	CONCRETE VOLUME. m ³ /10m ²	1.021	1.147	1.274	1.401	1.528	1.655	1.782	1.909

C.L. = CONSTRUCTION LOAD (Pa)

OUTPUT SECTION #2: PLOT DATA - AND INPUT SECTION AS SHOWN #

ITEM	DESCRIPTION	(hf) OR (hc) (mm)	# MAXIMUM SPECIFIED UNIFORMLY DISTRIBUTED LOAD (KPa)							
			4.07	4.31	4.79	5.27	5.75	6.22	6.70	6.94
1	ALLOW. SINGLE UNSUP. SPAN - m.	63.50	6.62	6.51	6.31	6.13	5.96	5.81	5.67	5.60
2	ALLOW. SINGLE UNSUP. SPAN - m.	76.20	6.63	6.53	6.34	6.17	6.01	5.86	5.72	5.66
3	ALLOW. SINGLE UNSUP. SPAN - m.	88.90	6.65	6.55	6.37	6.20	6.05	5.90	5.77	5.70
4	ALLOW. SINGLE UNSUP. SPAN - m.	101.60	6.66	6.57	6.39	6.23	6.08	5.94	5.81	5.75
5	ALLOW. SINGLE UNSUP. SPAN - m.	114.30	6.68	6.59	6.42	6.26	6.12	5.98	5.85	5.79
6	ALLOW. SINGLE UNSUP. SPAN - m.	127.00	6.69	6.60	6.44	6.29	6.15	6.02	5.89	5.83
7	ALLOW. SINGLE UNSUP. SPAN - m.	139.70	6.70	6.61	6.46	6.31	6.18	6.05	5.93	5.87
8	ALLOW. SINGLE UNSUP. SPAN - m.	152.40	6.71	6.63	6.48	6.33	6.20	6.08	5.96	5.90

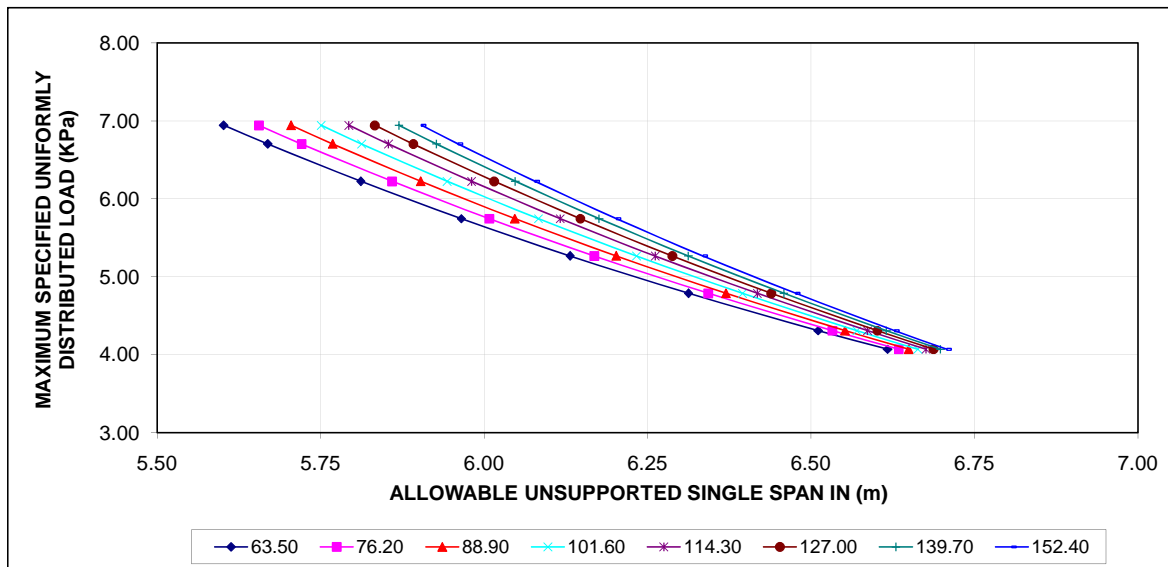



ULTRA-BOND COMPOSITE FLOOR DECK
 MAXIMUM SPECIFIED UNIFORMLY DISTRIBUTED LOAD (KPa)
 INCLUDES DEAD AND CONSTRUCTION LOAD CARRIED
 BY METAL DECK *(NOT SHOWN IN TABLES)*
 LIMIT STATE DESIGN (LSD) -METRIC UNITS

1.21 mm Deck
15 mm Rebar

INPUT SECTION:

ITEM	DESCRIPTION OR SECTION PROPERTIES	CONCRETE COVER ABOVE TOP OF METAL DECK (hf) OR (hc) (mm)							
		63.50	76.20	88.90	101.60	114.30	127.00	139.70	152.40
A	METAL DECK THICK (mm) (Td)	1.21	1.21	1.21	1.21	1.21	1.21	1.21	1.21
B	METAL DECK YIELD STRENGTH (KPa)(Fy)	280	280	280	280	280	280	280	280
C	METAL DECK EFF. (Ix) (mm ⁴)/m	6.95E+06	6.95E+06	6.95E+06	6.95E+06	6.95E+06	6.95E+06	6.95E+06	6.95E+06
D	METAL DECK EFF. (Sx) (mm ³)/m	6.18E+04	6.18E+04	6.18E+04	6.18E+04	6.18E+04	6.18E+04	6.18E+04	6.18E+04
E	METAL DECK (Es)(KPa)	2.03E+08	2.03E+08	2.03E+08	2.03E+08	2.03E+08	2.03E+08	2.03E+08	2.03E+08
F	# REINFORCING STEEL BAR DIA. (mm)	15	15	15	15	15	15	15	15
G	CONCRETE STRENGTH (f'c) (KPa)	3.00E+04	3.00E+04	3.00E+04	3.00E+04	3.00E+04	3.00E+04	3.00E+04	3.00E+04
H	CONCRETE (Ec) (KPa)	2.62E+07	2.62E+07	2.62E+07	2.62E+07	2.62E+07	2.62E+07	2.62E+07	2.62E+07
I	A _F (mm ²)/m	1830.917	1830.917	1830.917	1830.917	1830.917	1830.917	1830.917	1830.917
J	I _{x(f)} (mm ⁴)/m	9.80E+06	9.80E+06	9.80E+06	9.80E+06	9.80E+06	9.80E+06	9.80E+06	9.80E+06
K	ALLOWABLE FORCE (KN/m)	9.617	9.617	9.617	9.617	9.617	9.617	9.617	9.617
L	FINAL EFF. CROSS SECT. AREA A _{SO} (IN ²)	387	387	387	387	387	387	387	387
M	DEFLECTION CRITERIA K _{1,2,3,4}	1.333	1.333	1.333	1.333	1.333	1.333	1.333	1.333
N	DEFLECTION CRITERIA *	L/480	L/480	L/480	L/480	L/480	L/480	L/480	L/480

* DEFLECTION CRITERIA: L/360 (K₁=1), L/480 (K₂=1.333), L/600 (K₃=1.670) OR L/720 (K₄=2.0)
 # REINFORCING BAR Fy0=400MPa

OUTPUT SECTION #1

ITEM	DESCRIPTION	CONCRETE COVER ABOVE TOP OF METAL DECK (hf) OR (hc) (mm)							
		63.50	76.20	88.90	101.60	114.30	127.00	139.70	152.40
O	MAX. UNSHORED SPAN (C.L.1.006KPa).m.	4.32	3.98	3.70	3.45	3.23	3.04	2.87	2.72
P	MAX. UNSHORED SPAN (C.L.2.011KPa).m.	3.13	2.98	2.91	2.81	2.67	2.54	2.42	2.31
Q	TOTAL DEAD LOAD (NO CONST.).KPa.	2.560	2.859	3.158	3.458	3.757	4.056	4.355	4.654
R	CONCRETE VOLUME. m ³ /10m ²	1.017	1.144	1.271	1.398	1.525	1.652	1.779	1.906

C.L. = CONSTRUCTION LOAD (Pa)

OUTPUT SECTION #2: PLOT DATA - AND INPUT SECTION AS SHOWN #

ITEM	DESCRIPTION	(hf) OR (hc) (mm)	# MAXIMUM SPECIFIED UNIFORMLY DISTRIBUTED LOAD (KPa)							
			4.07	4.31	4.79	5.27	5.75	6.22	6.7	6.94
1	ALLOW. SINGLE UNSUP. SPAN - m.	63.50	7.48	7.36	7.13	6.93	6.74	6.57	6.41	6.33
2	ALLOW. SINGLE UNSUP. SPAN - m.	76.20	7.50	7.38	7.17	6.97	6.79	6.62	6.47	6.39
3	ALLOW. SINGLE UNSUP. SPAN - m.	88.90	7.52	7.41	7.20	7.01	6.84	6.67	6.52	6.45
4	ALLOW. SINGLE UNSUP. SPAN - m.	101.60	7.53	7.43	7.23	7.05	6.88	6.72	6.57	6.50
5	ALLOW. SINGLE UNSUP. SPAN - m.	114.30	7.55	7.45	7.26	7.08	6.92	6.76	6.62	6.55
6	ALLOW. SINGLE UNSUP. SPAN - m.	127.00	7.56	7.47	7.28	7.11	6.95	6.80	6.66	6.60
7	ALLOW. SINGLE UNSUP. SPAN - m.	139.70	7.58	7.48	7.30	7.14	6.99	6.84	6.70	6.64
8	ALLOW. SINGLE UNSUP. SPAN - m.	152.40	7.59	7.50	7.33	7.17	7.02	6.87	6.74	6.68

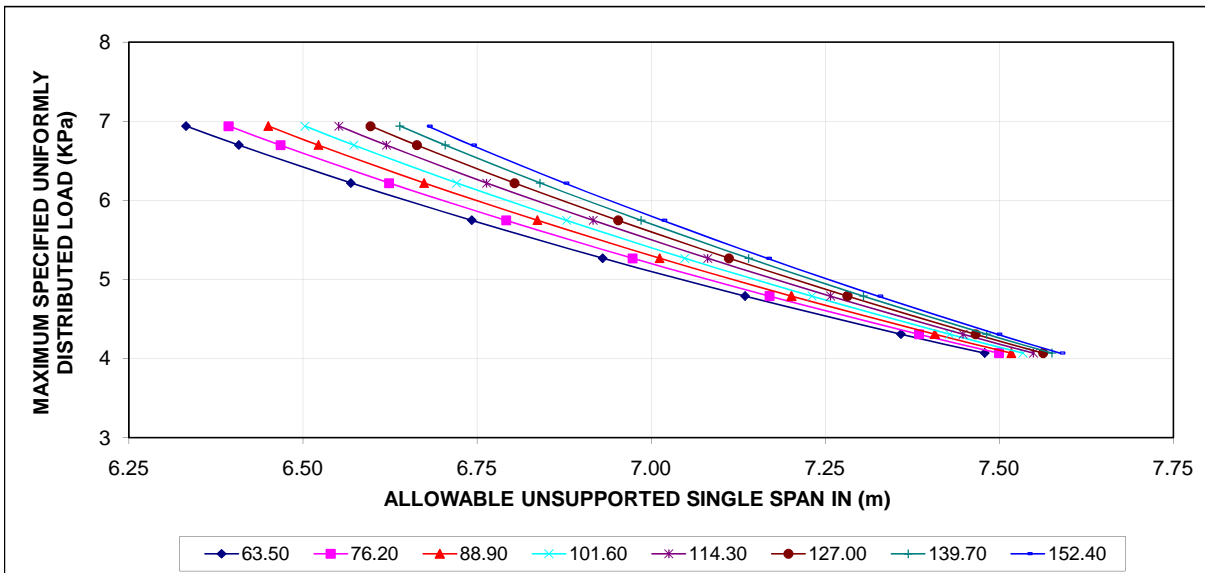



ULTRA-BOND COMPOSITE FLOOR DECK
 MAXIMUM SPECIFIED UNIFORMLY DISTRIBUTED LOAD (KPa)
 INCLUDES DEAD AND CONSTRUCTION LOAD CARRIED
 BY METAL DECK *(NOT SHOWN IN TABLES)*
 LIMIT STATE DESIGN (LSD) -METRIC UNITS

1.21 mm Deck
20 mm Rebar

INPUT SECTION:

ITEM	DESCRIPTION OR SECTION PROPERTIES	CONCRETE COVER ABOVE TOP OF METAL DECK (hf) OR (hc) (mm)							
		63.50	76.20	88.90	101.60	114.30	127.00	139.70	152.40
A	METAL DECK THICK (mm) (Td)	1.21	1.21	1.21	1.21	1.21	1.21	1.21	1.21
B	METAL DECK YIELD STRENGTH (KPa)(Fy)	280	280	280	280	280	280	280	280
C	METAL DECK EFF. (Ix) (mm ⁴)/m	6.95E+06	6.95E+06	6.95E+06	6.95E+06	6.95E+06	6.95E+06	6.95E+06	6.95E+06
D	METAL DECK EFF. (Sx) (mm ³)/m	6.18E+04	6.18E+04	6.18E+04	6.18E+04	6.18E+04	6.18E+04	6.18E+04	6.18E+04
E	METAL DECK (Es)(KPa)	2.03E+08	2.03E+08	2.03E+08	2.03E+08	2.03E+08	2.03E+08	2.03E+08	2.03E+08
F	# REINFORCING STEEL BAR DIA. (mm)	20	20	20	20	20	20	20	20
G	CONCRETE STRENGTH (f'c) (KPa)	3.00E+04	3.00E+04	3.00E+04	3.00E+04	3.00E+04	3.00E+04	3.00E+04	3.00E+04
H	CONCRETE (Ec) (KPa)	2.62E+07	2.62E+07	2.62E+07	2.62E+07	2.62E+07	2.62E+07	2.62E+07	2.62E+07
I	A _F (mm ²)/m	1830.917	1830.917	1830.917	1830.917	1830.917	1830.917	1830.917	1830.917
J	I _{x(f)} (mm ⁴)/m	9.80E+06	9.80E+06	9.80E+06	9.80E+06	9.80E+06	9.80E+06	9.80E+06	9.80E+06
K	ALLOWABLE FORCE (KN/m)	9.617	9.617	9.617	9.617	9.617	9.617	9.617	9.617
L	FINAL EFF. CROSS SECT. AREA A _{SO} (IN ²)	434	434	434	434	434	434	434	434
M	DEFLECTION CRITERIA K _{1,2,3,4}	1.333	1.333	1.333	1.333	1.333	1.333	1.333	1.333
N	DEFLECTION CRITERIA *	L/480	L/480	L/480	L/480	L/480	L/480	L/480	L/480

* DEFLECTION CRITERIA: L/360 (K₁=1), L/480 (K₂=1.333), L/600 (K₃=1.670) OR L/720 (K₄=2.0)
 # REINFORCING BAR Fy0=400MPa

OUTPUT SECTION #1

ITEM	DESCRIPTION	CONCRETE COVER ABOVE TOP OF METAL DECK (hf) OR (hc) (mm)							
		63.50	76.20	88.90	101.60	114.30	127.00	139.70	152.40
O	MAX. UNSHORED SPAN (C.L.1.006KPa).m.	4.31	3.97	3.69	3.44	3.23	3.04	2.87	2.72
P	MAX. UNSHORED SPAN (C.L.2.011KPa).m.	3.13	2.97	2.91	2.81	2.66	2.53	2.41	2.31
Q	TOTAL DEAD LOAD (NO CONST.)KPa.	2.567	2.866	3.165	3.464	3.763	4.063	4.362	4.661
R	CONCRETE VOLUME. m ³ /10m ²	1.013	1.140	1.267	1.394	1.521	1.648	1.775	1.901

C.L. = CONSTRUCTION LOAD (Pa)

OUTPUT SECTION #2: PLOT DATA - AND INPUT SECTION AS SHOWN #

ITEM	DESCRIPTION	(hf) OR (hc) (mm)	# MAXIMUM SPECIFIED UNIFORMLY DISTRIBUTED LOAD (KPa)							
			4.07	4.31	4.79	5.27	5.75	6.22	6.70	6.94
1	ALLOW. SINGLE UNSUP. SPAN - m.	63.50	7.81	7.66	7.39	7.16	6.96	6.78	6.61	6.53
2	ALLOW. SINGLE UNSUP. SPAN - m.	76.20	7.92	7.80	7.57	7.37	7.17	7.00	6.83	6.75
3	ALLOW. SINGLE UNSUP. SPAN - m.	88.90	7.94	7.83	7.61	7.41	7.22	7.05	6.89	6.82
4	ALLOW. SINGLE UNSUP. SPAN - m.	101.60	7.96	7.85	7.64	7.45	7.27	7.10	6.95	6.87
5	ALLOW. SINGLE UNSUP. SPAN - m.	114.30	7.98	7.87	7.67	7.48	7.31	7.15	7.00	6.92
6	ALLOW. SINGLE UNSUP. SPAN - m.	127.00	7.99	7.89	7.70	7.51	7.35	7.19	7.04	6.97
7	ALLOW. SINGLE UNSUP. SPAN - m.	139.70	8.01	7.91	7.72	7.55	7.38	7.23	7.09	7.02
8	ALLOW. SINGLE UNSUP. SPAN - m.	152.40	8.02	7.92	7.74	7.57	7.42	7.27	7.13	7.06

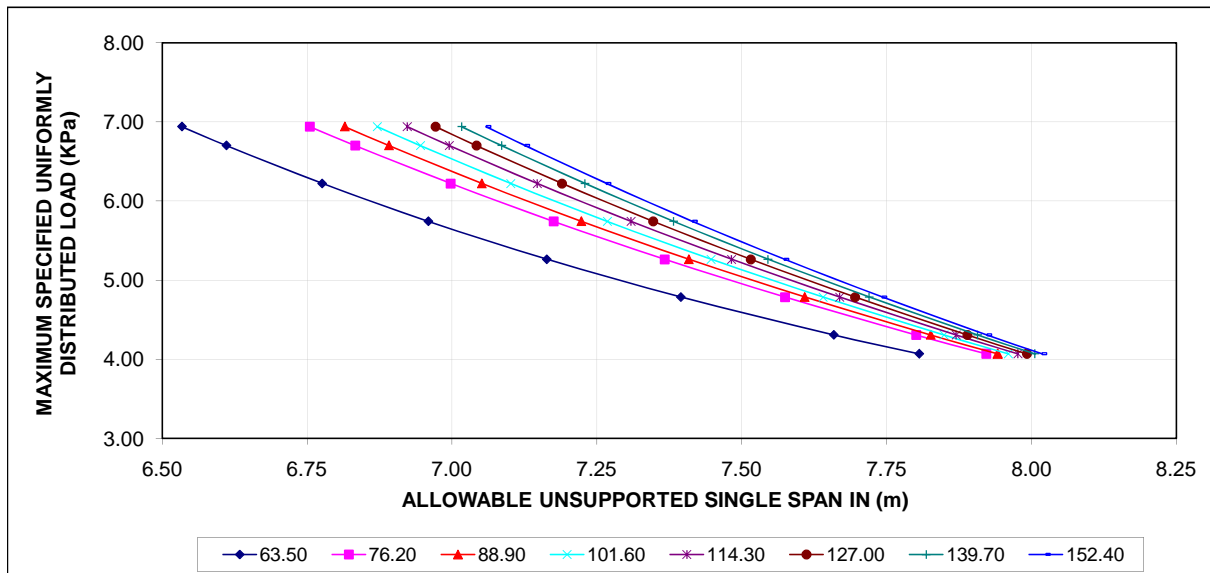



ULTRA-BOND COMPOSITE FLOOR DECK
 MAXIMUM SPECIFIED UNIFORMLY DISTRIBUTED LOAD (KPa)
 INCLUDES DEAD AND CONSTRUCTION LOAD CARRIED
 BY METAL DECK *(NOT SHOWN IN TABLES)*
 LIMIT STATE DESIGN (LSD) -METRIC UNITS

1.21 mm Deck
25 mm Rebar

INPUT SECTION:

ITEM	DESCRIPTION OR SECTION PROPERTIES	CONCRETE COVER ABOVE TOP OF METAL DECK (hf) OR (hc) (mm)							
		63.50	76.20	88.90	101.60	114.30	127.00	139.70	152.40
A	METAL DECK THICK (mm) (Td)	1.21	1.21	1.21	1.21	1.21	1.21	1.21	1.21
B	METAL DECK YIELD STRENGTH (KPa)(Fy)	280	280	280	280	280	280	280	280
C	METAL DECK EFF. (I _x) (mm ⁴)/m	6.95E+06	6.95E+06	6.95E+06	6.95E+06	6.95E+06	6.95E+06	6.95E+06	6.95E+06
D	METAL DECK EFF. (S _x) (mm ³)/m	6.18E+04	6.18E+04	6.18E+04	6.18E+04	6.18E+04	6.18E+04	6.18E+04	6.18E+04
E	METAL DECK (E _s)(KPa)	2.03E+08	2.03E+08	2.03E+08	2.03E+08	2.03E+08	2.03E+08	2.03E+08	2.03E+08
F	# REINFORCING STEEL BAR DIA. (mm)	25	25	25	25	25	25	25	25
G	CONCRETE STRENGTH (f'c) (KPa)	3.00E+04	3.00E+04	3.00E+04	3.00E+04	3.00E+04	3.00E+04	3.00E+04	3.00E+04
H	CONCRETE (E _c) (KPa)	2.62E+07	2.62E+07	2.62E+07	2.62E+07	2.62E+07	2.62E+07	2.62E+07	2.62E+07
I	A _F (mm ²)/m	1830.917	1830.917	1830.917	1830.917	1830.917	1830.917	1830.917	1830.917
J	I _{x(f)} (mm ⁴)/m	9.80E+06	9.80E+06	9.80E+06	9.80E+06	9.80E+06	9.80E+06	9.80E+06	9.80E+06
K	ALLOWABLE FORCE (KN/m)	9.617	9.617	9.617	9.617	9.617	9.617	9.617	9.617
L	FINAL EFF. CROSS SECT. AREA A _{SO} (IN ²)	581	581	581	581	581	581	581	581
M	DEFLECTION CRITERIA K _{1,2,3,4}	1.333	1.333	1.333	1.333	1.333	1.333	1.333	1.333
N	DEFLECTION CRITERIA *	L/480	L/480	L/480	L/480	L/480	L/480	L/480	L/480

* DEFLECTION CRITERIA: L/360 (K₁=1), L/480 (K₂=1.333), L/600 (K₃=1.670) OR L/720 (K₄=2.0)
 # REINFORCING BAR Fy0=400MPa

OUTPUT SECTION #1

ITEM	DESCRIPTION	CONCRETE COVER ABOVE TOP OF METAL DECK (hf) OR (hc) (mm)							
		63.50	76.20	88.90	101.60	114.30	127.00	139.70	152.40
O	MAX. UNSHORED SPAN (C.L.1.006KPa).m.	4.30	3.97	3.68	3.44	3.22	3.03	2.86	2.71
P	MAX. UNSHORED SPAN (C.L.2.011KPa).m.	3.14	2.97	2.92	2.81	2.66	2.53	2.41	2.30
Q	TOTAL DEAD LOAD (NO CONST.) KPa.	2.576	2.875	3.174	3.473	3.772	4.071	4.370	4.670
R	CONCRETE VOLUME. m ³ /10m ²	1.007	1.134	1.261	1.388	1.515	1.642	1.769	1.896

C.L. = CONSTRUCTION LOAD (Pa)

OUTPUT SECTION #2: PLOT DATA - AND INPUT SECTION AS SHOWN #

ITEM	DESCRIPTION	(hf) OR (hc) (mm)	# MAXIMUM SPECIFIED UNIFORMLY DISTRIBUTED LOAD (KPa)							
			4.07	4.31	4.79	5.27	5.75	6.22	6.7	6.94
1	ALLOW. SINGLE UNSUP. SPAN - m.	63.50	7.88	7.73	7.46	7.23	7.02	6.84	6.67	6.59
2	ALLOW. SINGLE UNSUP. SPAN - m.	76.20	8.29	8.13	7.85	7.60	7.39	7.19	7.02	6.94
3	ALLOW. SINGLE UNSUP. SPAN - m.	88.90	8.69	8.53	8.24	7.98	7.75	7.55	7.36	7.28
4	ALLOW. SINGLE UNSUP. SPAN - m.	101.60	9.10	8.93	8.63	8.36	8.12	7.90	7.71	7.62
5	ALLOW. SINGLE UNSUP. SPAN - m.	114.30	9.19	9.07	8.84	8.62	8.42	8.24	8.06	7.97
6	ALLOW. SINGLE UNSUP. SPAN - m.	127.00	9.21	9.09	8.87	8.66	8.47	8.29	8.12	8.04
7	ALLOW. SINGLE UNSUP. SPAN - m.	139.70	9.23	9.12	8.90	8.70	8.51	8.34	8.17	8.09
8	ALLOW. SINGLE UNSUP. SPAN - m.	152.40	9.25	9.14	8.93	8.73	8.55	8.38	8.22	8.14

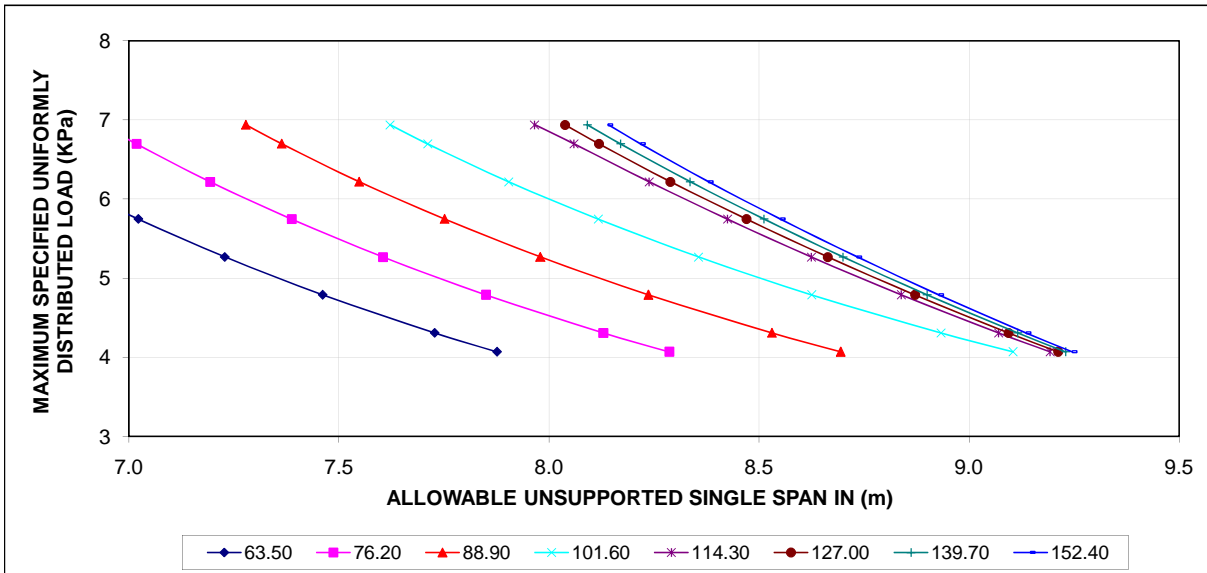



ULTRA-BOND COMPOSITE FLOOR DECK
 MAXIMUM SPECIFIED UNIFORMLY DISTRIBUTED LOAD (KPa)
 INCLUDES DEAD AND CONSTRUCTION LOAD CARRIED
 BY METAL DECK *(NOT SHOWN IN TABLES)*
 LIMIT STATE DESIGN (LSD) -METRIC UNITS

1.21 mm Deck
30 mm Rebar

INPUT SECTION:

ITEM	DESCRIPTION OR SECTION PROPERTIES	CONCRETE COVER ABOVE TOP OF METAL DECK (hf) OR (hc) (mm)							
		63.50	76.20	88.90	101.60	114.30	127.00	139.70	152.40
A	METAL DECK THICK (mm) (Td)	1.21	1.21	1.21	1.21	1.21	1.21	1.21	1.21
B	METAL DECK YIELD STRENGTH (KPa)(Fy)	280	280	280	280	280	280	280	280
C	METAL DECK EFF. (Ix) (mm ⁴)/m	6.95E+06	6.95E+06	6.95E+06	6.95E+06	6.95E+06	6.95E+06	6.95E+06	6.95E+06
D	METAL DECK EFF. (Sx) (mm ³)/m	6.18E+04	6.18E+04	6.18E+04	6.18E+04	6.18E+04	6.18E+04	6.18E+04	6.18E+04
E	METAL DECK (Es)(KPa)	2.03E+08	2.03E+08	2.03E+08	2.03E+08	2.03E+08	2.03E+08	2.03E+08	2.03E+08
F	# REINFORCING STEEL BAR DIA. (mm)	30	30	30	30	30	30	30	30
G	CONCRETE STRENGTH (f'c) (KPa)	3.00E+04	3.00E+04	3.00E+04	3.00E+04	3.00E+04	3.00E+04	3.00E+04	3.00E+04
H	CONCRETE (Ec) (KPa)	2.62E+07	2.62E+07	2.62E+07	2.62E+07	2.62E+07	2.62E+07	2.62E+07	2.62E+07
I	A _F (mm ²)/m	1830.917	1830.917	1830.917	1830.917	1830.917	1830.917	1830.917	1830.917
J	I _{x(f)} (mm ⁴)/m	9.80E+06	9.80E+06	9.80E+06	9.80E+06	9.80E+06	9.80E+06	9.80E+06	9.80E+06
K	ALLOWABLE FORCE (KN/m)	9.617	9.617	9.617	9.617	9.617	9.617	9.617	9.617
L	FINAL EFF. CROSS SECT. AREA A _{SO} (IN ²)	706	706	706	706	706	706	706	706
M	DEFLECTION CRITERIA K _{1,2,3,4}	1.333	1.333	1.333	1.333	1.333	1.333	1.333	1.333
N	DEFLECTION CRITERIA *	L/480	L/480	L/480	L/480	L/480	L/480	L/480	L/480

* DEFLECTION CRITERIA: L/360 (K₁=1), L/480 (K₂=1.333), L/600 (K₃=1.670) OR L/720 (K₄=2.0)
 # REINFORCING BAR Fy0=400MPa

OUTPUT SECTION #1

ITEM	DESCRIPTION	CONCRETE COVER ABOVE TOP OF METAL DECK (hf) OR (hc) (mm)							
		63.50	76.20	88.90	101.60	114.30	127.00	139.70	152.40
O	MAX. UNSHORED SPAN (C.L.1.006KPa).m.	4.28	3.95	3.67	3.43	3.21	3.02	2.86	2.71
P	MAX. UNSHORED SPAN (C.L.2.011KPa).m.	3.14	2.93	2.96	2.80	2.66	2.53	2.41	2.30
Q	TOTAL DEAD LOAD (NO CONST.) KPa.	2.586	2.885	3.184	3.484	3.783	4.082	4.381	4.680
R	CONCRETE VOLUME. m ³ /10m ²	1.000	1.127	1.254	1.381	1.508	1.635	1.762	1.889

C.L. = CONSTRUCTION LOAD (Pa)

OUTPUT SECTION #2: PLOT DATA - AND INPUT SECTION AS SHOWN #

ITEM	DESCRIPTION	(hf) OR (hc) (mm)	# MAXIMUM SPECIFIED UNIFORMLY DISTRIBUTED LOAD (KPa)							
			4.07	4.31	4.79	5.27	5.75	6.22	6.70	6.94
1	ALLOW. SINGLE UNSUP. SPAN - m.	63.50	7.95	7.80	7.53	7.30	7.09	6.90	6.73	6.66
2	ALLOW. SINGLE UNSUP. SPAN - m.	76.20	8.38	8.22	7.94	7.69	7.47	7.27	7.10	7.01
3	ALLOW. SINGLE UNSUP. SPAN - m.	88.90	8.80	8.64	8.34	8.08	7.85	7.64	7.46	7.37
4	ALLOW. SINGLE UNSUP. SPAN - m.	101.60	9.23	9.06	8.74	8.47	8.23	8.01	7.82	7.73
5	ALLOW. SINGLE UNSUP. SPAN - m.	114.30	9.66	9.48	9.15	8.86	8.61	8.38	8.18	8.09
6	ALLOW. SINGLE UNSUP. SPAN - m.	127.00	10.09	9.90	9.56	9.26	8.99	8.76	8.54	8.44
7	ALLOW. SINGLE UNSUP. SPAN - m.	139.70	10.15	10.02	9.78	9.56	9.36	9.13	8.91	8.81
8	ALLOW. SINGLE UNSUP. SPAN - m.	152.40	10.17	10.04	9.82	9.60	9.40	9.21	9.04	8.95

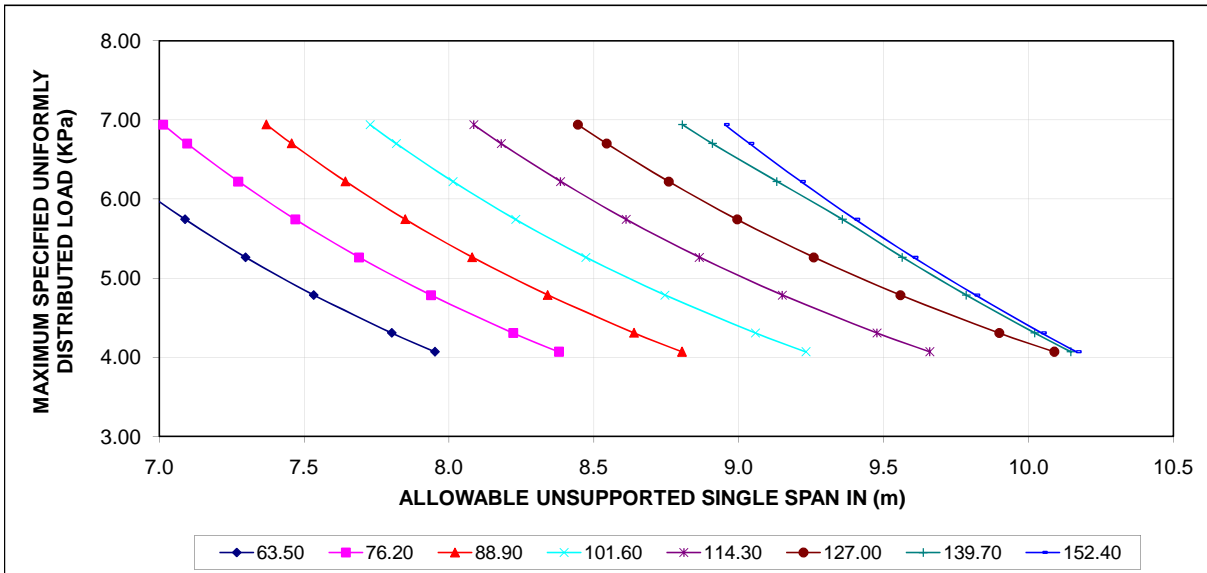



ULTRA-BOND COMPOSITE FLOOR DECK
 MAXIMUM SPECIFIED UNIFORMLY DISTRIBUTED LOAD (KPa)
 INCLUDES DEAD AND CONSTRUCTION LOAD CARRIED
 BY METAL DECK *(NOT SHOWN IN TABLES)*
 LIMIT STATE DESIGN (LSD) -METRIC UNITS

0.96mm Deck
10mm Rebar

INPUT SECTION:

ITEM	DESCRIPTION OR SECTION PROPERTIES	CONCRETE COVER ABOVE TOP OF METAL DECK (hf) OR (hc) (mm)							
		63.50	76.20	88.90	101.60	114.30	127.00	139.70	152.40
A	METAL DECK THICK (mm) (Td)	0.96	0.96	0.96	0.96	0.96	0.96	0.96	0.96
B	METAL DECK YIELD STRENGTH (KPa)(Fy)	280	280	280	280	280	280	280	280
C	METAL DECK EFF. (Ix) (mm ⁴ /m)	4.60E+06	4.60E+06	4.60E+06	4.60E+06	4.60E+06	4.60E+06	4.60E+06	4.60E+06
D	METAL DECK EFF. (Sx) (mm ³ /m)	3.68E+04	3.68E+04	3.68E+04	3.68E+04	3.68E+04	3.68E+04	3.68E+04	3.68E+04
E	METAL DECK (Es)(KPa)	2.03E+08	2.03E+08	2.03E+08	2.03E+08	2.03E+08	2.03E+08	2.03E+08	2.03E+08
F	# REINFORCING STEEL BAR DIA. (mm)	10	10	10	10	10	10	10	10
G	CONCRETE STRENGTH (f'c) (KPa)	3.00E+04	3.00E+04	3.00E+04	3.00E+04	3.00E+04	3.00E+04	3.00E+04	3.00E+04
H	CONCRETE (Ec) (KPa)	2.62E+07	2.62E+07	2.62E+07	2.62E+07	2.62E+07	2.62E+07	2.62E+07	2.62E+07
I	A _F (mm ² /m)	1454.150	1454.150	1454.150	1454.150	1454.150	1454.150	1454.150	1454.150
J	I _{x(F)} (mm ⁴ /m)	7.78E+06	7.78E+06	7.78E+06	7.78E+06	7.78E+06	7.78E+06	7.78E+06	7.78E+06
K	ALLOWABLE FORCE (KN/m)	6.378	6.378	6.378	6.378	6.378	6.378	6.378	6.378
L	FINAL EFF. CROSS SECT. AREA A _{SO} (IN ²)	240	240	240	240	240	240	240	240
M	DEFLECTION CRITERIA K _{1,2,3,4}	1.000	1.000	1.000	1.000	1.000	1.000	1.000	1.000

* DEFLECTION CRITERIA: L/360 (K₁=1), L/480 (K₂=1.333), L/600 (K₃=1.670) OR L/720 (K₄=2.0)
 # REINFORCING BAR Fy0=400MPa

OUTPUT SECTION #1

ITEM	DESCRIPTION	CONCRETE COVER ABOVE TOP OF METAL DECK (hf) OR (hc) (mm)							
		63.50	76.20	88.90	101.60	114.30	127.00	139.70	152.40
O	MAX. UNSHORED SPAN (C.L.1.006KPa).m.	2.89	2.66	2.47	2.30	2.16	2.03	1.92	1.81
P	MAX. UNSHORED SPAN (C.L.2.011KPa).m.	2.25	2.11	1.99	1.88	1.78	1.69	1.61	1.54
Q	TOTAL DEAD LOAD (NO CONST.).KPa.	2.526	2.826	3.125	3.424	3.723	4.022	4.321	4.620
R	CONCRETE VOLUME. m ³ /10m ²	1.021	1.147	1.274	1.401	1.528	1.655	1.782	1.909

C.L. = CONSTRUCTION LOAD (Pa)

OUTPUT SECTION #2: PLOT DATA - AND INPUT SECTION AS SHOWN #

ITEM	DESCRIPTION	(hf) OR (hc) (mm)	# MAXIMUM SPECIFIED UNIFORMLY DISTRIBUTED LOAD (KPa)							
			4.07	4.31	4.79	5.27	5.75	6.22	6.70	6.94
1	ALLOW. SINGLE UNSUP. SPAN - m.	63.50	5.93	5.84	5.66	5.50	5.35	5.21	5.08	5.02
2	ALLOW. SINGLE UNSUP. SPAN - m.	76.20	5.95	5.86	5.69	5.53	5.38	5.25	5.13	5.07
3	ALLOW. SINGLE UNSUP. SPAN - m.	88.90	5.96	5.87	5.71	5.56	5.42	5.29	5.17	5.11
4	ALLOW. SINGLE UNSUP. SPAN - m.	101.60	5.97	5.89	5.73	5.58	5.45	5.32	5.21	5.15
5	ALLOW. SINGLE UNSUP. SPAN - m.	114.30	5.98	5.90	5.75	5.61	5.48	5.36	5.24	5.19
6	ALLOW. SINGLE UNSUP. SPAN - m.	127.00	5.99	5.91	5.77	5.63	5.51	5.39	5.28	5.22
7	ALLOW. SINGLE UNSUP. SPAN - m.	139.70	6.00	5.93	5.78	5.65	5.53	5.42	5.31	5.26
8	ALLOW. SINGLE UNSUP. SPAN - m.	152.40	6.01	5.94	5.80	5.67	5.55	5.44	5.34	5.29

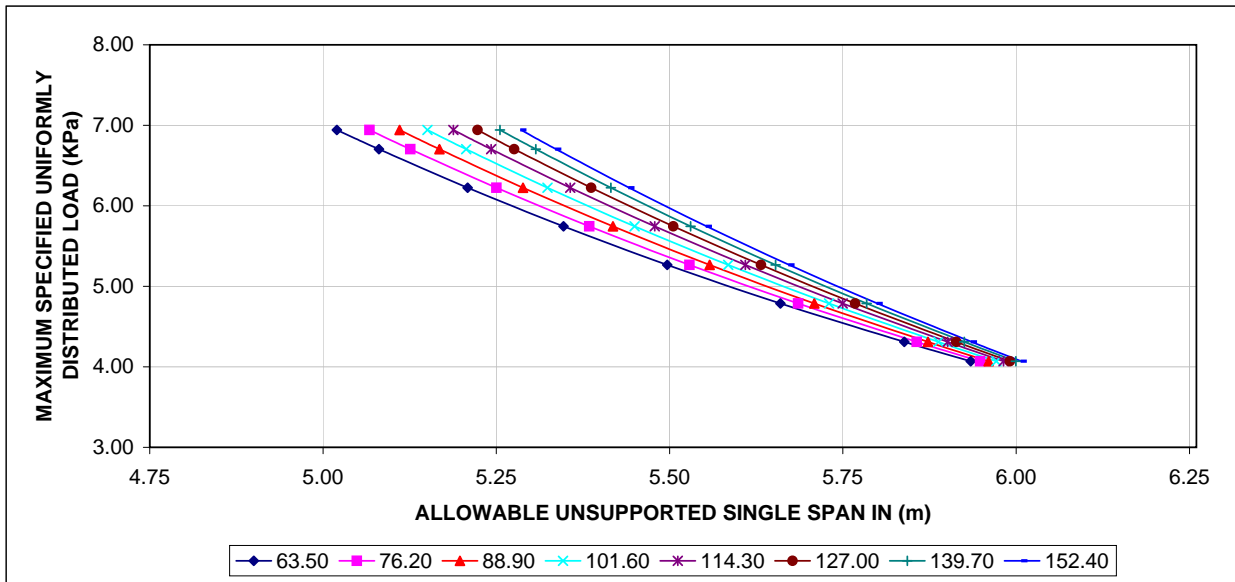



ULTRA-BOND COMPOSITE FLOOR DECK
 MAXIMUM SPECIFIED UNIFORMLY DISTRIBUTED LOAD (KPa)
 INCLUDES DEAD AND CONSTRUCTION LOAD CARRIED
 BY METAL DECK *(NOT SHOWN IN TABLES)*
 LIMIT STATE DESIGN (LSD) -METRIC UNITS

0.96mm Deck
15mm Rebar

INPUT SECTION:

ITEM	DESCRIPTION OR SECTION PROPERTIES	CONCRETE COVER ABOVE TOP OF METAL DECK (hf) OR (hc) (mm)							
		63.50	76.20	88.90	101.60	114.30	127.00	139.70	152.40
A	METAL DECK THICK (mm) (Td)	0.96	0.96	0.96	0.96	0.96	0.96	0.96	0.96
B	METAL DECK YIELD STRENGTH (KPa)(Fy)	280	280	280	280	280	280	280	280
C	METAL DECK EFF. (Ix) (mm ⁴)/m	4.60E+06	4.60E+06	4.60E+06	4.60E+06	4.60E+06	4.60E+06	4.60E+06	4.60E+06
D	METAL DECK EFF. (Sx) (mm ³)/m	3.68E+04	3.68E+04	3.68E+04	3.68E+04	3.68E+04	3.68E+04	3.68E+04	3.68E+04
E	METAL DECK (Es)(KPa)	2.03E+08	2.03E+08	2.03E+08	2.03E+08	2.03E+08	2.03E+08	2.03E+08	2.03E+08
F	# REINFORCING STEEL BAR DIA. (mm)	15	15	15	15	15	15	15	15
G	CONCRETE STRENGTH (f'c) (KPa)	3.00E+04	3.00E+04	3.00E+04	3.00E+04	3.00E+04	3.00E+04	3.00E+04	3.00E+04
H	CONCRETE (Ec) (KPa)	2.62E+07	2.62E+07	2.62E+07	2.62E+07	2.62E+07	2.62E+07	2.62E+07	2.62E+07
I	A _F (mm ²)/m	1454.150	1454.150	1454.150	1454.150	1454.150	1454.150	1454.150	1454.150
J	I _{x(F)} (mm ⁴)/m	7.78E+06	7.78E+06	7.78E+06	7.78E+06	7.78E+06	7.78E+06	7.78E+06	7.78E+06
K	ALLOWABLE FORCE (KN/m)	6.378	6.378	6.378	6.378	6.378	6.378	6.378	6.378
L	FINAL EFF. CROSS SECT. AREA A _{SO} (IN ²)	323	323	323	323	323	323	323	323
M	DEFLECTION CRITERIA K _{1,2,3,4}	1.000	1.000	1.000	1.000	1.000	1.000	1.000	1.000

* DEFLECTION CRITERIA: L/360 (K₁=1), L/480 (K₂=1.333), L/600 (K₃=1.670) OR L/720 (K₄=2.0)
 # REINFORCING BAR Fy0=400MPa

OUTPUT SECTION #1

ITEM	DESCRIPTION	CONCRETE COVER ABOVE TOP OF METAL DECK (hf) OR (hc) (mm)							
		63.50	76.20	88.90	101.60	114.30	127.00	139.70	152.40
O	MAX. UNSHORED SPAN (C.L.1.006KPa).m.	2.89	2.66	2.47	2.30	2.16	2.03	1.91	1.81
P	MAX. UNSHORED SPAN (C.L.2.011KPa).m.	2.25	2.11	1.99	1.88	1.78	1.69	1.61	1.54
Q	TOTAL DEAD LOAD (NO CONST.).KPa.	2.531	2.830	3.129	3.429	3.728	4.027	4.326	4.625
R	CONCRETE VOLUME. m ³ /10m ²	1.017	1.144	1.271	1.398	1.525	1.652	1.779	1.906

C.L. = CONSTRUCTION LOAD (Pa)

OUTPUT SECTION #2: PLOT DATA - AND INPUT SECTION AS SHOWN #

ITEM	DESCRIPTION	(hf) OR (hc) (mm)	# MAXIMUM SPECIFIED UNIFORMLY DISTRIBUTED LOAD (KPa)							
			4.07	4.31	4.79	5.27	5.75	6.22	6.70	6.94
1	ALLOW. SINGLE UNSUP. SPAN - m.	63.50	6.86	6.75	6.54	6.36	6.18	6.02	5.87	5.80
2	ALLOW. SINGLE UNSUP. SPAN - m.	76.20	6.88	6.77	6.57	6.39	6.23	6.07	5.93	5.86
3	ALLOW. SINGLE UNSUP. SPAN - m.	88.90	6.89	6.79	6.60	6.43	6.27	6.12	5.98	5.91
4	ALLOW. SINGLE UNSUP. SPAN - m.	101.60	6.91	6.81	6.63	6.46	6.30	6.16	6.02	5.96
5	ALLOW. SINGLE UNSUP. SPAN - m.	114.30	6.92	6.83	6.65	6.49	6.34	6.20	6.06	6.00
6	ALLOW. SINGLE UNSUP. SPAN - m.	127.00	6.93	6.84	6.67	6.52	6.37	6.23	6.10	6.04
7	ALLOW. SINGLE UNSUP. SPAN - m.	139.70	6.94	6.86	6.69	6.54	6.40	6.27	6.14	6.08
8	ALLOW. SINGLE UNSUP. SPAN - m.	152.40	6.95	6.87	6.71	6.56	6.43	6.30	6.17	6.12

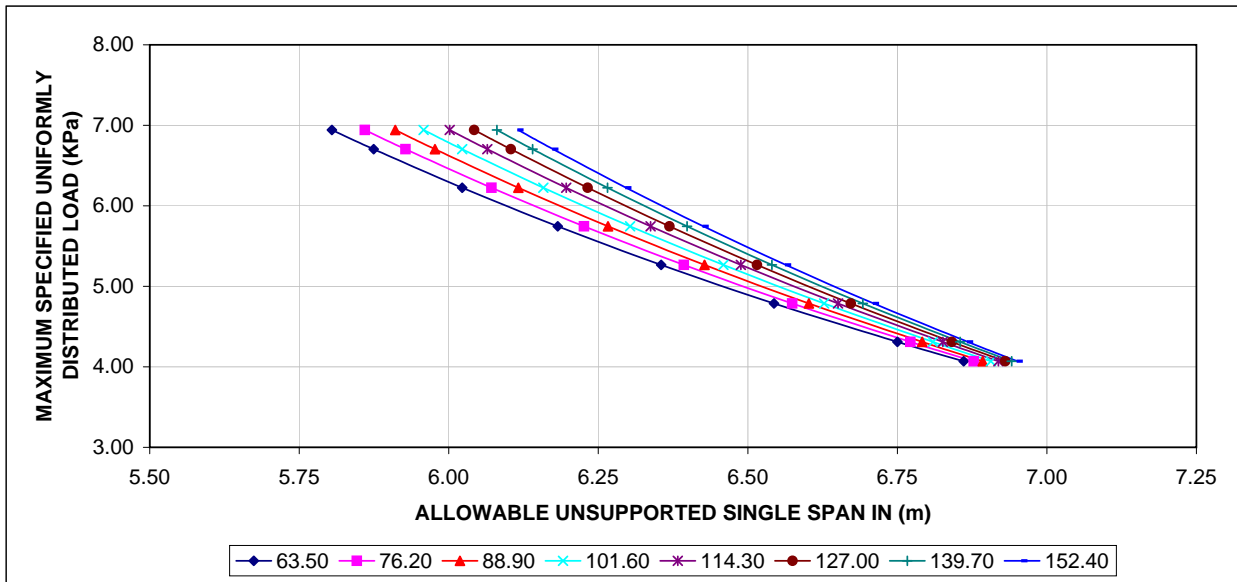



ULTRA-BOND COMPOSITE FLOOR DECK
 MAXIMUM SPECIFIED UNIFORMLY DISTRIBUTED LOAD (KPa)
 INCLUDES DEAD AND CONSTRUCTION LOAD CARRIED
 BY METAL DECK *(NOT SHOWN IN TABLES)*
 LIMIT STATE DESIGN (LSD) -METRIC UNITS

0.96mm Deck
20mm Rebar

INPUT SECTION:

ITEM	DESCRIPTION OR SECTION PROPERTIES	CONCRETE COVER ABOVE TOP OF METAL DECK (hf) OR (hc) (mm)							
		63.50	76.20	88.90	101.60	114.30	127.00	139.70	152.40
A	METAL DECK THICK (mm) (Td)	0.96	0.96	0.96	0.96	0.96	0.96	0.96	0.96
B	METAL DECK YIELD STRENGTH (KPa)(Fy)	280	280	280	280	280	280	280	280
C	METAL DECK EFF. (Ix) (mm ⁴)/m	4.60E+06	4.60E+06	4.60E+06	4.60E+06	4.60E+06	4.60E+06	4.60E+06	4.60E+06
D	METAL DECK EFF. (Sx) (mm ³)/m	3.68E+04	3.68E+04	3.68E+04	3.68E+04	3.68E+04	3.68E+04	3.68E+04	3.68E+04
E	METAL DECK (Es)(KPa)	2.03E+08	2.03E+08	2.03E+08	2.03E+08	2.03E+08	2.03E+08	2.03E+08	2.03E+08
F	# REINFORCING STEEL BAR DIA. (mm)	20	20	20	20	20	20	20	20
G	CONCRETE STRENGTH (f'c) (KPa)	3.00E+04	3.00E+04	3.00E+04	3.00E+04	3.00E+04	3.00E+04	3.00E+04	3.00E+04
H	CONCRETE (Ec) (KPa)	2.62E+07	2.62E+07	2.62E+07	2.62E+07	2.62E+07	2.62E+07	2.62E+07	2.62E+07
I	A _F (mm ²)/m	1454.150	1454.150	1454.150	1454.150	1454.150	1454.150	1454.150	1454.150
J	I _{x(F)} (mm ⁴)/m	7.78E+06	7.78E+06	7.78E+06	7.78E+06	7.78E+06	7.78E+06	7.78E+06	7.78E+06
K	ALLOWABLE FORCE (KN/m)	6.378	6.378	6.378	6.378	6.378	6.378	6.378	6.378
L	FINAL EFF. CROSS SECT. AREA A _{SO} (IN ²)	361	361	361	361	361	361	361	361
M	DEFLECTION CRITERIA K _{1,2,3,4}	1.000	1.000	1.000	1.000	1.000	1.000	1.000	1.000

* DEFLECTION CRITERIA: L/360 (K₁=1), L/480 (K₂=1.333), L/600 (K₃=1.670) OR L/720 (K₄=2.0)
 # REINFORCING BAR Fy0=400MPa

OUTPUT SECTION #1

ITEM	DESCRIPTION	CONCRETE COVER ABOVE TOP OF METAL DECK (hf) OR (hc) (mm)							
		63.50	76.20	88.90	101.60	114.30	127.00	139.70	152.40
O	MAX. UNSHORED SPAN (C.L.1.006KPa).m.	2.88	2.66	2.46	2.30	2.15	2.02	1.91	1.81
P	MAX. UNSHORED SPAN (C.L.2.011KPa).m.	2.24	2.10	1.98	1.87	1.78	1.69	1.61	1.54
Q	TOTAL DEAD LOAD (NO CONST.).KPa.	2.538	2.837	3.136	3.435	3.734	4.034	4.333	4.632
R	CONCRETE VOLUME. m ³ /10m ²	1.013	1.140	1.267	1.394	1.521	1.648	1.775	1.901

C.L. = CONSTRUCTION LOAD (Pa)

OUTPUT SECTION #2: PLOT DATA - AND INPUT SECTION AS SHOWN #

ITEM	DESCRIPTION	(hf) OR (hc) (mm)	# MAXIMUM SPECIFIED UNIFORMLY DISTRIBUTED LOAD (KPa)							
			4.07	4.31	4.79	5.27	5.75	6.22	6.70	6.94
1	ALLOW. SINGLE UNSUP. SPAN - m.	63.50	7.25	7.13	6.91	6.71	6.53	6.36	6.21	6.13
2	ALLOW. SINGLE UNSUP. SPAN - m.	76.20	7.27	7.16	6.95	6.76	6.58	6.42	6.26	6.19
3	ALLOW. SINGLE UNSUP. SPAN - m.	88.90	7.28	7.18	6.98	6.79	6.62	6.46	6.32	6.25
4	ALLOW. SINGLE UNSUP. SPAN - m.	101.60	7.30	7.20	7.00	6.83	6.66	6.51	6.36	6.30
5	ALLOW. SINGLE UNSUP. SPAN - m.	114.30	7.31	7.21	7.03	6.86	6.70	6.55	6.41	6.34
6	ALLOW. SINGLE UNSUP. SPAN - m.	127.00	7.32	7.23	7.05	6.89	6.73	6.59	6.45	6.39
7	ALLOW. SINGLE UNSUP. SPAN - m.	139.70	7.34	7.25	7.07	6.91	6.76	6.62	6.49	6.43
8	ALLOW. SINGLE UNSUP. SPAN - m.	152.40	7.35	7.26	7.09	6.94	6.79	6.66	6.53	6.47

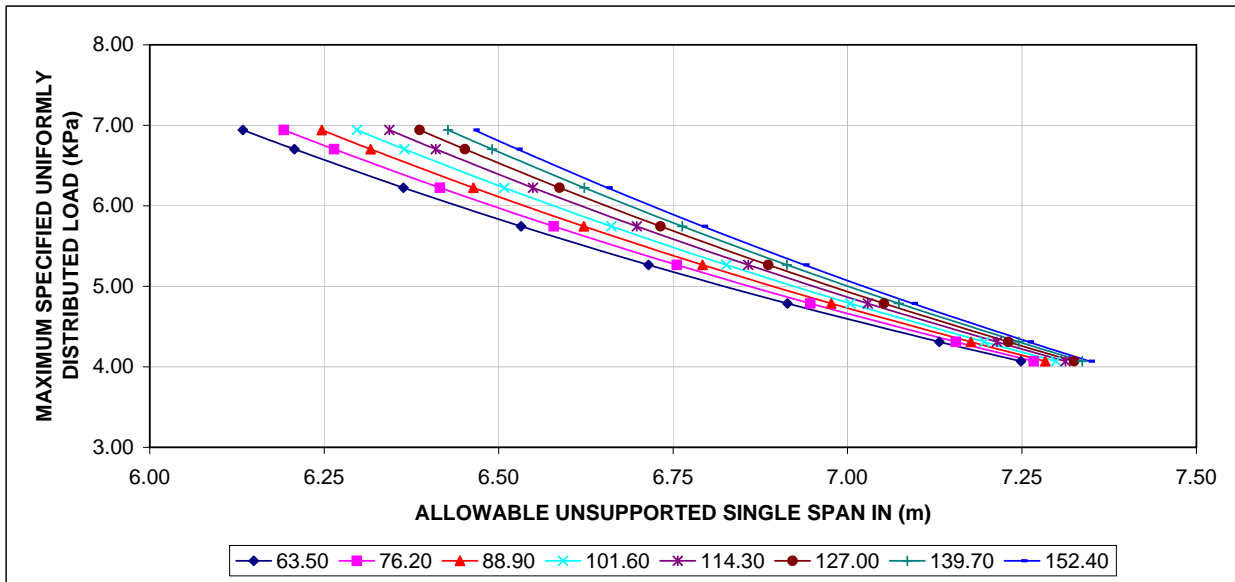



ULTRA-BOND COMPOSITE FLOOR DECK
 MAXIMUM SPECIFIED UNIFORMLY DISTRIBUTED LOAD (KPa)
 INCLUDES DEAD AND CONSTRUCTION LOAD CARRIED
 BY METAL DECK *(NOT SHOWN IN TABLES)*
 LIMIT STATE DESIGN (LSD) -METRIC UNITS

0.96mm Deck
25mm Rebar

INPUT SECTION:

ITEM	DESCRIPTION OR SECTION PROPERTIES	CONCRETE COVER ABOVE TOP OF METAL DECK (hf) OR (hc) (mm)							
		63.50	76.20	88.90	101.60	114.30	127.00	139.70	152.40
A	METAL DECK THICK (mm) (Td)	0.96	0.96	0.96	0.96	0.96	0.96	0.96	0.96
B	METAL DECK YIELD STRENGTH (KPa)(Fy)	280	280	280	280	280	280	280	280
C	METAL DECK EFF. (Ix) (mm ⁴)/m	4.60E+06	4.60E+06	4.60E+06	4.60E+06	4.60E+06	4.60E+06	4.60E+06	4.60E+06
D	METAL DECK EFF. (Sx) (mm ³)/m	3.68E+04	3.68E+04	3.68E+04	3.68E+04	3.68E+04	3.68E+04	3.68E+04	3.68E+04
E	METAL DECK (Es)(KPa)	2.03E+08	2.03E+08	2.03E+08	2.03E+08	2.03E+08	2.03E+08	2.03E+08	2.03E+08
F	# REINFORCING STEEL BAR DIA. (mm)	25	25	25	25	25	25	25	25
G	CONCRETE STRENGTH (f'c) (KPa)	3.00E+04	3.00E+04	3.00E+04	3.00E+04	3.00E+04	3.00E+04	3.00E+04	3.00E+04
H	CONCRETE (Ec) (KPa)	2.62E+07	2.62E+07	2.62E+07	2.62E+07	2.62E+07	2.62E+07	2.62E+07	2.62E+07
I	A _F (mm ²)/m	1454.150	1454.150	1454.150	1454.150	1454.150	1454.150	1454.150	1454.150
J	I _{x(F)} (mm ⁴)/m	7.78E+06	7.78E+06	7.78E+06	7.78E+06	7.78E+06	7.78E+06	7.78E+06	7.78E+06
K	ALLOWABLE FORCE (KN/m)	6.378	6.378	6.378	6.378	6.378	6.378	6.378	6.378
L	FINAL EFF. CROSS SECT. AREA A _{SO} (IN ²)	490	490	490	490	490	490	490	490
M	DEFLECTION CRITERIA K _{1,2,3,4}	1.000	1.000	1.000	1.000	1.000	1.000	1.000	1.000

* DEFLECTION CRITERIA: L/360 (K₁=1), L/480 (K₂=1.333), L/600 (K₃=1.670) OR L/720 (K₄=2.0)
 # REINFORCING BAR Fy0=400MPa

OUTPUT SECTION #1

ITEM	DESCRIPTION	CONCRETE COVER ABOVE TOP OF METAL DECK (hf) OR (hc) (mm)							
		63.50	76.20	88.90	101.60	114.30	127.00	139.70	152.40
O	MAX. UNSHORED SPAN (C.L.1.006KPa).m.	2.87	2.65	2.46	2.29	2.15	2.02	1.91	1.81
P	MAX. UNSHORED SPAN (C.L.2.011KPa).m.	2.24	2.10	1.98	1.87	1.77	1.69	1.61	1.53
Q	TOTAL DEAD LOAD (NO CONST.).KPa.	2.547	2.846	3.145	3.444	3.743	4.042	4.341	4.641
R	CONCRETE VOLUME. m ³ /10m ²	1.007	1.134	1.261	1.388	1.515	1.642	1.769	1.896

C.L. = CONSTRUCTION LOAD (Pa)

OUTPUT SECTION #2: PLOT DATA - AND INPUT SECTION AS SHOWN #

ITEM	DESCRIPTION	(hf) OR (hc) (mm)	# MAXIMUM SPECIFIED UNIFORMLY DISTRIBUTED LOAD (KPa)							
			4.07	4.31	4.79	5.27	5.75	6.22	6.70	6.94
1	ALLOW. SINGLE UNSUP. SPAN - m.	63.50	8.41	8.27	8.02	7.79	7.58	7.38	7.20	7.11
2	ALLOW. SINGLE UNSUP. SPAN - m.	76.20	8.43	8.30	8.06	7.84	7.63	7.44	7.27	7.18
3	ALLOW. SINGLE UNSUP. SPAN - m.	88.90	8.45	8.33	8.10	7.88	7.68	7.50	7.33	7.25
4	ALLOW. SINGLE UNSUP. SPAN - m.	101.60	8.47	8.35	8.13	7.92	7.73	7.55	7.39	7.31
5	ALLOW. SINGLE UNSUP. SPAN - m.	114.30	8.49	8.37	8.16	7.96	7.78	7.60	7.44	7.36
6	ALLOW. SINGLE UNSUP. SPAN - m.	127.00	8.50	8.39	8.19	8.00	7.82	7.65	7.49	7.42
7	ALLOW. SINGLE UNSUP. SPAN - m.	139.70	8.52	8.41	8.21	8.03	7.85	7.69	7.54	7.46
8	ALLOW. SINGLE UNSUP. SPAN - m.	152.40	8.53	8.43	8.24	8.06	7.89	7.73	7.58	7.51

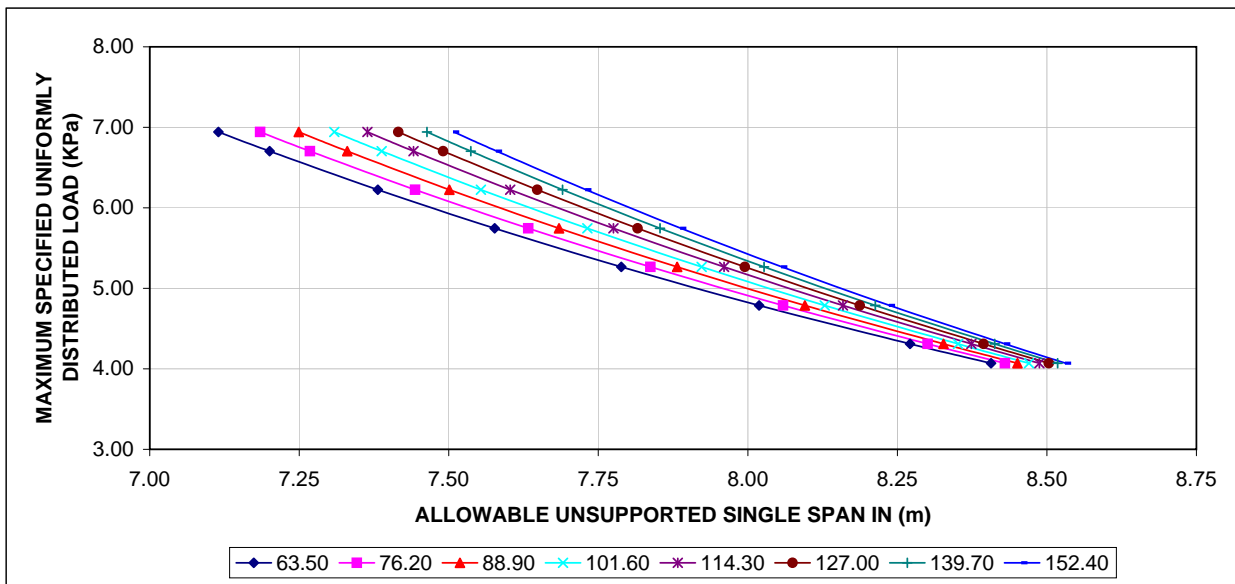



ULTRA-BOND COMPOSITE FLOOR DECK
 MAXIMUM SPECIFIED UNIFORMLY DISTRIBUTED LOAD (KPa)
 INCLUDES DEAD AND CONSTRUCTION LOAD CARRIED
 BY METAL DECK *(NOT SHOWN IN TABLES)*
 LIMIT STATE DESIGN (LSD) -METRIC UNITS

0.96mm Deck
30mm Rebar

INPUT SECTION:

ITEM	DESCRIPTION OR SECTION PROPERTIES	CONCRETE COVER ABOVE TOP OF METAL DECK (hf) OR (hc) (mm)							
		63.50	76.20	88.90	101.60	114.30	127.00	139.70	152.40
A	METAL DECK THICK (mm) (Td)	0.96	0.96	0.96	0.96	0.96	0.96	0.96	0.96
B	METAL DECK YIELD STRENGTH (KPa)(Fy)	280	280	280	280	280	280	280	280
C	METAL DECK EFF. (Ix) (mm ⁴)/m	4.60E+06	4.60E+06	4.60E+06	4.60E+06	4.60E+06	4.60E+06	4.60E+06	4.60E+06
D	METAL DECK EFF. (Sx) (mm ³)/m	3.68E+04	3.68E+04	3.68E+04	3.68E+04	3.68E+04	3.68E+04	3.68E+04	3.68E+04
E	METAL DECK (Es)(KPa)	2.03E+08	2.03E+08	2.03E+08	2.03E+08	2.03E+08	2.03E+08	2.03E+08	2.03E+08
F	# REINFORCING STEEL BAR DIA. (mm)	30	30	30	30	30	30	30	30
G	CONCRETE STRENGTH (f'c) (KPa)	3.00E+04	3.00E+04	3.00E+04	3.00E+04	3.00E+04	3.00E+04	3.00E+04	3.00E+04
H	CONCRETE (Ec) (KPa)	2.62E+07	2.62E+07	2.62E+07	2.62E+07	2.62E+07	2.62E+07	2.62E+07	2.62E+07
I	A _F (mm ²)/m	1454.150	1454.150	1454.150	1454.150	1454.150	1454.150	1454.150	1454.150
J	I _{x(F)} (mm ⁴)/m	7.78E+06	7.78E+06	7.78E+06	7.78E+06	7.78E+06	7.78E+06	7.78E+06	7.78E+06
K	ALLOWABLE FORCE (KN/m)	6.378	6.378	6.378	6.378	6.378	6.378	6.378	6.378
L	FINAL EFF. CROSS SECT. AREA A _{SO} (IN ²)	706	706	706	706	706	706	706	706
M	DEFLECTION CRITERIA K _{1,2,3,4}	1.000	1.000	1.000	1.000	1.000	1.000	1.000	1.000

* DEFLECTION CRITERIA: L/360 (K₁=1), L/480 (K₂=1.333), L/600 (K₃=1.670) OR L/720 (K₄=2.0)
 # REINFORCING BAR Fy0=400MPa

OUTPUT SECTION #1

ITEM	DESCRIPTION	CONCRETE COVER ABOVE TOP OF METAL DECK (hf) OR (hc) (mm)							
		63.50	76.20	88.90	101.60	114.30	127.00	139.70	152.40
O	MAX. UNSHORED SPAN (C.L.1.006KPa).m.	2.86	2.64	2.45	2.29	2.14	2.02	1.90	1.80
P	MAX. UNSHORED SPAN (C.L.2.011KPa).m.	2.23	2.10	1.98	1.87	1.77	1.68	1.60	1.53
Q	TOTAL DEAD LOAD (NO CONST.).KPa.	2.557	2.856	3.155	3.455	3.754	4.053	4.352	4.651
R	CONCRETE VOLUME. m ³ /10m ²	1.000	1.127	1.254	1.381	1.508	1.635	1.762	1.889

C.L. = CONSTRUCTION LOAD (Pa)

OUTPUT SECTION #2: PLOT DATA - AND INPUT SECTION AS SHOWN #

ITEM	DESCRIPTION	(hf) OR (hc) (mm)	# MAXIMUM SPECIFIED UNIFORMLY DISTRIBUTED LOAD (KPa)							
			4.07	4.31	4.79	5.27	5.75	6.22	6.70	6.94
1	ALLOW. SINGLE UNSUP. SPAN - m.	63.50	8.61	8.45	8.16	7.90	7.68	7.48	7.29	7.21
2	ALLOW. SINGLE UNSUP. SPAN - m.	76.20	9.08	8.91	8.60	8.33	8.10	7.88	7.69	7.60
3	ALLOW. SINGLE UNSUP. SPAN - m.	88.90	9.55	9.37	9.05	8.76	8.51	8.29	8.09	7.99
4	ALLOW. SINGLE UNSUP. SPAN - m.	101.60	10.02	9.83	9.49	9.19	8.93	8.69	8.48	8.38
5	ALLOW. SINGLE UNSUP. SPAN - m.	114.30	10.13	9.99	9.74	9.50	9.28	9.07	8.88	8.78
6	ALLOW. SINGLE UNSUP. SPAN - m.	127.00	10.15	10.02	9.77	9.54	9.33	9.13	8.94	8.85
7	ALLOW. SINGLE UNSUP. SPAN - m.	139.70	10.17	10.04	9.81	9.58	9.38	9.18	9.00	8.91
8	ALLOW. SINGLE UNSUP. SPAN - m.	152.40	10.19	10.07	9.84	9.62	9.42	9.23	9.05	8.97

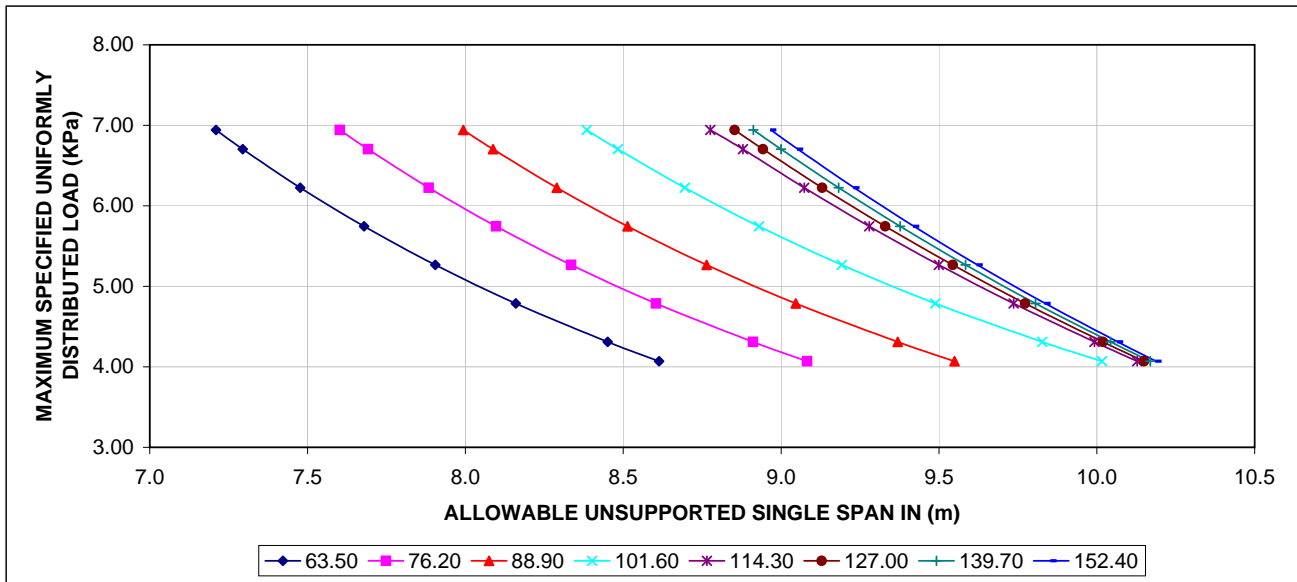



ULTRA-BOND COMPOSITE FLOOR DECK

MAXIMUM SPECIFIED UNIFORMLY DISTRIBUTED LOAD (P.S.F)

INCLUDES DEAD AND CONSTRUCTION LOAD CARRIED

BY METAL DECK *(NOT SHOWN IN TABLES)*

LIMIT STATE DESIGN (LSD) - **IMPERIAL UNITS**

0.0476" Deck
0.394" Rebar

INPUT SECTION:

ITEM	DESCRIPTION OR SECTION PROPERTIES	CONCRETE COVER ABOVE TOP OF METAL DECK (hf) OR (hc) (IN)							
		2.50	3.00	3.50	4.00	4.50	5.00	5.50	6.00
A	METAL DECK THICK (INCH) (Td)	0.0476	0.0476	0.0476	0.0476	0.0476	0.0476	0.0476	0.0476
B	METAL DECK YIELD STRENGTH (KSI)(Fy)	40.6	40.6	40.6	40.6	40.6	40.6	40.6	40.6
C	METAL DECK EFF. (Ix) (IN ⁴)/FT	5.09	5.09	5.09	5.09	5.09	5.09	5.09	5.09
D	METAL DECK EFF. (Sx) (IN ³)/FT	1.15	1.15	1.15	1.15	1.15	1.15	1.15	1.15
E	METAL DECK (Es)(PSI)	2.95E+07	2.95E+07	2.95E+07	2.95E+07	2.95E+07	2.95E+07	2.95E+07	2.95E+07
F	# REINFORCING STEEL BAR DIA. (INCH)	0.394	0.394	0.394	0.394	0.394	0.394	0.394	0.394
G	CONCRETE STRENGTH (f'c) (PSI)	4350	4350	4350	4350	4350	4350	4350	4350
H	CONCRETE (Ec) (PSI)	3.80E+06	3.80E+06	3.80E+06	3.80E+06	3.80E+06	3.80E+06	3.80E+06	3.80E+06
I	A _F (IN ²)/FT	0.865	0.865	0.865	0.865	0.865	0.865	0.865	0.865
J	I _{x(F)} (IN ⁴)/FT	7.18	7.18	7.18	7.18	7.18	7.18	7.18	7.18
K	ALLOWABLE FORCE (LBS/FT)	659	659	659	659	659	659	659	659
L	FINAL EFF. CROSS SECT. AREA A _{SO} (IN ²)	0.467	0.467	0.467	0.467	0.467	0.467	0.467	0.467
M	DEFLECTION CRITERIA K _{1,2,3,4}	1.333	1.333	1.333	1.333	1.333	1.333	1.333	1.333
N	DEFLECTION CRITERIA *	L/480	L/480	L/480	L/480	L/480	L/480	L/480	L/480

* DEFLECTION CRITERIA: L/360 (K₁=1), L/480 (K₂=1.333), L/600 (K₃=1.670) OR L/720 (K₄=2.0)

REINFORCING BAR Fy0=58.0KSI

OUTPUT SECTION #1

ITEM	DESCRIPTION	CONCRETE COVER ABOVE TOP OF METAL DECK (hf) OR (hc) (IN)							
		2.50	3.00	3.50	4.00	4.50	5.00	5.50	6.00
O	MAX. UNSHORED SPAN (C.L.21PSF).FT.	14.18	13.08	12.14	11.32	10.61	9.98	9.43	8.93
P	MAX. UNSHORED SPAN (C.L.42PSF).FT.	9.47	9.38	9.24	9.06	8.76	8.33	7.94	7.58
Q	TOTAL DEAD LOAD (NO CONST.).PSF.	53.37	59.62	65.87	72.11	78.36	84.61	90.86	97.10
R	CONCRETE VOLUME. YD ³ /100FT ²	1.240	1.394	1.549	1.703	1.857	2.011	2.166	2.320

C.L. = CONSTRUCTION LOAD (PSF)

OUTPUT SECTION #2: PLOT DATA - AND INPUT SECTION AS SHOWN #

ITEM	DESCRIPTION	(hf) OR (hc) (IN)	# MAXIMUM SPECIFIED UNIFORMLY DISTRIBUTED LOAD (P.S.F)							
			150	200	250	300	350	400	450	500
1	ALLOW. SINGLE UNSUP. SPAN - FT.	2.50	17.83	15.44	13.81	12.61	11.67	10.92	10.29	9.76
2	ALLOW. SINGLE UNSUP. SPAN - FT.	3.00	18.33	15.87	14.20	12.96	12.00	11.22	10.58	10.04
3	ALLOW. SINGLE UNSUP. SPAN - FT.	3.50	18.81	16.29	14.57	13.30	12.32	11.52	10.86	10.30
4	ALLOW. SINGLE UNSUP. SPAN - FT.	4.00	19.29	16.70	14.94	13.64	12.63	11.81	11.14	10.56
5	ALLOW. SINGLE UNSUP. SPAN - FT.	4.50	19.75	17.10	15.30	13.96	12.93	12.09	11.40	10.82
6	ALLOW. SINGLE UNSUP. SPAN - FT.	5.00	20.20	17.49	15.65	14.28	13.22	12.37	11.66	11.06
7	ALLOW. SINGLE UNSUP. SPAN - FT.	5.50	20.64	17.88	15.99	14.60	13.51	12.64	11.92	11.31
8	ALLOW. SINGLE UNSUP. SPAN - FT.	6.00	21.08	18.25	16.33	14.90	13.80	12.91	12.17	11.54

Figures shown in yellow to be multiplied by a factor of **0.9** - See Manual (Creep Stress)

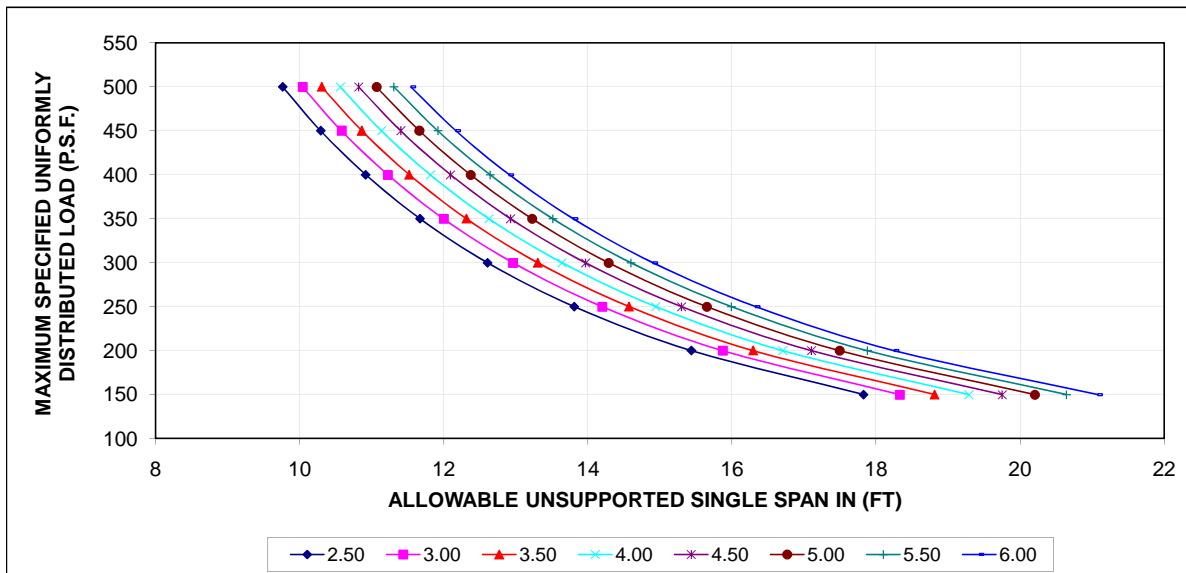



ULTRA-BOND COMPOSITE FLOOR DECK
 MAXIMUM SPECIFIED UNIFORMLY DISTRIBUTED LOAD (P.S.F)
 INCLUDES DEAD AND CONSTRUCTION LOAD CARRIED
 BY METAL DECK *(NOT SHOWN IN TABLES)*
 LIMIT STATE DESIGN (LSD) - IMPERIAL UNITS

0.0476" Deck
0.591" Rebar

INPUT SECTION:

ITEM	DESCRIPTION OR SECTION PROPERTIES	CONCRETE COVER ABOVE TOP OF METAL DECK (hf) OR (hc) (IN)							
		2.50	3.00	3.50	4.00	4.50	5.00	5.50	6.00
A	METAL DECK THICK (INCH) (Td)	0.0476	0.0476	0.0476	0.0476	0.0476	0.0476	0.0476	0.0476
B	METAL DECK YIELD STRENGTH (KSI)(Fy)	40.6	40.6	40.6	40.6	40.6	40.6	40.6	40.6
C	METAL DECK EFF. (Ix) (IN ⁴)/FT	5.09	5.09	5.09	5.09	5.09	5.09	5.09	5.09
D	METAL DECK EFF. (Sx) (IN ³)/FT	1.15	1.15	1.15	1.15	1.15	1.15	1.15	1.15
E	METAL DECK (Es)(PSI)	2.95E+07	2.95E+07	2.95E+07	2.95E+07	2.95E+07	2.95E+07	2.95E+07	2.95E+07
F	# REINFORCING STEEL BAR DIA. (INCH)	0.591	0.591	0.591	0.591	0.591	0.591	0.591	0.591
G	CONCRETE STRENGTH (f'c) (PSI)	4350	4350	4350	4350	4350	4350	4350	4350
H	CONCRETE (Ec) (PSI)	3.80E+06	3.80E+06	3.80E+06	3.80E+06	3.80E+06	3.80E+06	3.80E+06	3.80E+06
I	A _F (IN ²)/FT	0.865	0.865	0.865	0.865	0.865	0.865	0.865	0.865
J	I _{x(F)} (IN ⁴)/FT	7.18	7.18	7.18	7.18	7.18	7.18	7.18	7.18
K	ALLOWABLE FORCE (LBS/FT)	659	659	659	659	659	659	659	659
L	FINAL EFF. CROSS SECT. AREA A _{SO} (IN ²)	0.600	0.600	0.600	0.600	0.600	0.600	0.600	0.600
M	DEFLECTION CRITERIA K _{1,2,3,4}	1.333	1.333	1.333	1.333	1.333	1.333	1.333	1.333
N	DEFLECTION CRITERIA *	L/480	L/480	L/480	L/480	L/480	L/480	L/480	L/480

* DEFLECTION CRITERIA: L/360 (K₁=1), L/480 (K₂=1.333), L/600 (K₃=1.670) OR L/720 (K₄=2.0)
 # REINFORCING BAR Fy0=58.0KSI

OUTPUT SECTION #1

ITEM	DESCRIPTION	CONCRETE COVER ABOVE TOP OF METAL DECK (hf) OR (hc) (IN)							
		2.50	3.00	3.50	4.00	4.50	5.00	5.50	6.00
O	MAX. UNSHORED SPAN (C.L.21PSF).FT.	14.16	13.06	12.12	11.31	10.60	9.97	9.42	8.92
P	MAX. UNSHORED SPAN (C.L.42PSF).FT.	9.47	9.39	9.23	9.07	8.75	8.32	7.93	7.57
Q	TOTAL DEAD LOAD (NO CONST.).PSF.	53.47	59.72	65.97	72.21	78.46	84.71	90.96	97.20
R	CONCRETE VOLUME. YD ³ /100FT ²	1.236	1.390	1.545	1.699	1.853	2.007	2.162	2.316

C.L. = CONSTRUCTION LOAD (PSF)

OUTPUT SECTION #2: PLOT DATA - AND INPUT SECTION AS SHOWN #

ITEM	DESCRIPTION	(hf) OR (hc) (IN)	# MAXIMUM SPECIFIED UNIFORMLY DISTRIBUTED LOAD (P.S.F)							
			150	200	250	300	350	400	450	500
1	ALLOW. SINGLE UNSUP. SPAN - FT.	2.50	20.16	17.46	15.61	14.25	13.20	12.34	11.64	11.04
2	ALLOW. SINGLE UNSUP. SPAN - FT.	3.00	20.72	17.95	16.05	14.65	13.57	12.69	11.97	11.35
3	ALLOW. SINGLE UNSUP. SPAN - FT.	3.50	21.28	18.43	16.48	15.04	13.93	13.03	12.28	11.65
4	ALLOW. SINGLE UNSUP. SPAN - FT.	4.00	21.81	18.89	16.90	15.43	14.28	13.36	12.59	11.95
5	ALLOW. SINGLE UNSUP. SPAN - FT.	4.50	22.34	19.35	17.30	15.80	14.63	13.68	12.90	12.24
6	ALLOW. SINGLE UNSUP. SPAN - FT.	5.00	22.85	19.79	17.70	16.16	14.96	13.99	13.19	12.52
7	ALLOW. SINGLE UNSUP. SPAN - FT.	5.50	23.36	20.23	18.09	16.52	15.29	14.30	13.48	12.79
8	ALLOW. SINGLE UNSUP. SPAN - FT.	6.00	23.85	20.65	18.47	16.86	15.61	14.60	13.77	13.06

Figures shown in yellow to be multiplied by a factor of 0.9 - See Manual (Creep Stress)

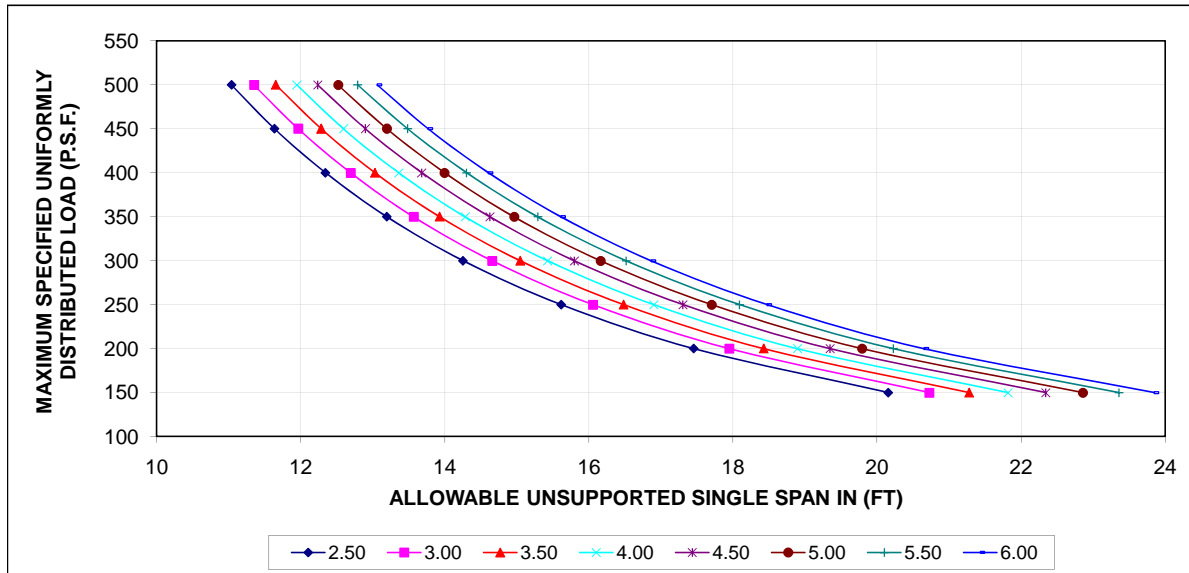



ULTRA-BOND COMPOSITE FLOOR DECK
 MAXIMUM SPECIFIED UNIFORMLY DISTRIBUTED LOAD (P.S.F)
 INCLUDES DEAD AND CONSTRUCTION LOAD CARRIED
 BY METAL DECK *(NOT SHOWN IN TABLES)*
 LIMIT STATE DESIGN (LSD) - **IMPERIAL UNITS**

0.0476" Deck
0.787" Rebar

INPUT SECTION:

ITEM	DESCRIPTION OR SECTION PROPERTIES	CONCRETE COVER ABOVE TOP OF METAL DECK (hf) OR (hc) (IN)							
		2.50	3.00	3.50	4.00	4.50	5.00	5.50	6.00
A	METAL DECK THICK (INCH) (Td)	0.0476	0.0476	0.0476	0.0476	0.0476	0.0476	0.0476	0.0476
B	METAL DECK YIELD STRENGTH (KSI)(Fy)	40.6	40.6	40.6	40.6	40.6	40.6	40.6	40.6
C	METAL DECK EFF. (Ix) (IN ⁴)/FT	5.09	5.09	5.09	5.09	5.09	5.09	5.09	5.09
D	METAL DECK EFF. (Sx) (IN ³)/FT	1.15	1.15	1.15	1.15	1.15	1.15	1.15	1.15
E	METAL DECK (Es)(PSI)	2.95E+07	2.95E+07	2.95E+07	2.95E+07	2.95E+07	2.95E+07	2.95E+07	2.95E+07
F	# REINFORCING STEEL BAR DIA. (INCH)	0.787	0.787	0.787	0.787	0.787	0.787	0.787	0.787
G	CONCRETE STRENGTH (f'c) (PSI)	4350	4350	4350	4350	4350	4350	4350	4350
H	CONCRETE (Ec) (PSI)	3.80E+06	3.80E+06	3.80E+06	3.80E+06	3.80E+06	3.80E+06	3.80E+06	3.80E+06
I	A _F (IN ²)/FT	0.865	0.865	0.865	0.865	0.865	0.865	0.865	0.865
J	I _{x(F)} (IN ⁴)/FT	7.18	7.18	7.18	7.18	7.18	7.18	7.18	7.18
K	ALLOWABLE FORCE (LBS/FT)	659	659	659	659	659	659	659	659
L	FINAL EFF. CROSS SECT. AREA A _{SO} (IN ²)	0.672	0.672	0.672	0.672	0.672	0.672	0.672	0.672
M	DEFLECTION CRITERIA K _{1,2,3,4}	1.333	1.333	1.333	1.333	1.333	1.333	1.333	1.333
N	DEFLECTION CRITERIA *	L/480	L/480	L/480	L/480	L/480	L/480	L/480	L/480

* DEFLECTION CRITERIA: L/360 (K₁=1), L/480 (K₂=1.333), L/600 (K₃=1.670) OR L/720 (K₄=2.0)
 # REINFORCING BAR Fy0=58.0KSI

OUTPUT SECTION #1

ITEM	DESCRIPTION	CONCRETE COVER ABOVE TOP OF METAL DECK (hf) OR (hc) (IN)							
		2.50	3.00	3.50	4.00	4.50	5.00	5.50	6.00
O	MAX. UNSHORED SPAN (C.L.21PSF).FT.	14.13	13.04	12.10	11.29	10.59	9.96	9.41	8.91
P	MAX. UNSHORED SPAN (C.L.42PSF).FT.	9.48	9.40	9.22	9.09	8.74	8.31	7.92	7.57
Q	TOTAL DEAD LOAD (NO CONST.).PSF.	53.61	59.86	66.11	72.35	78.60	84.85	91.10	97.34
R	CONCRETE VOLUME. YD ³ /100FT ²	1.231	1.385	1.539	1.693	1.848	2.002	2.156	2.310

C.L. = CONSTRUCTION LOAD (PSF)

OUTPUT SECTION #2: PLOT DATA - AND INPUT SECTION AS SHOWN #

ITEM	DESCRIPTION	(hf) OR (hc) (IN)	# MAXIMUM SPECIFIED UNIFORMLY DISTRIBUTED LOAD (P.S.F)							
			150	200	250	300	350	400	450	500
1	ALLOW. SINGLE UNSUP. SPAN - FT.	2.50	21.20	18.45	16.50	15.06	13.95	13.05	12.30	11.67
2	ALLOW. SINGLE UNSUP. SPAN - FT.	3.00	21.90	18.97	16.97	15.49	14.34	13.41	12.65	12.00
3	ALLOW. SINGLE UNSUP. SPAN - FT.	3.50	22.49	19.48	17.42	15.90	14.72	13.77	12.98	12.32
4	ALLOW. SINGLE UNSUP. SPAN - FT.	4.00	23.06	19.97	17.86	16.31	15.10	14.12	13.31	12.63
5	ALLOW. SINGLE UNSUP. SPAN - FT.	4.50	23.62	20.45	18.29	16.70	15.46	14.46	13.64	12.94
6	ALLOW. SINGLE UNSUP. SPAN - FT.	5.00	24.16	20.92	18.71	17.08	15.82	14.80	13.95	13.23
7	ALLOW. SINGLE UNSUP. SPAN - FT.	5.50	24.69	21.38	19.13	17.46	16.17	15.12	14.26	13.52
8	ALLOW. SINGLE UNSUP. SPAN - FT.	6.00	25.21	21.84	19.53	17.83	16.51	15.44	14.56	13.81

Figures shown in yellow to be multiplied by a factor of 0.9 - See Manual (Creep Stress)

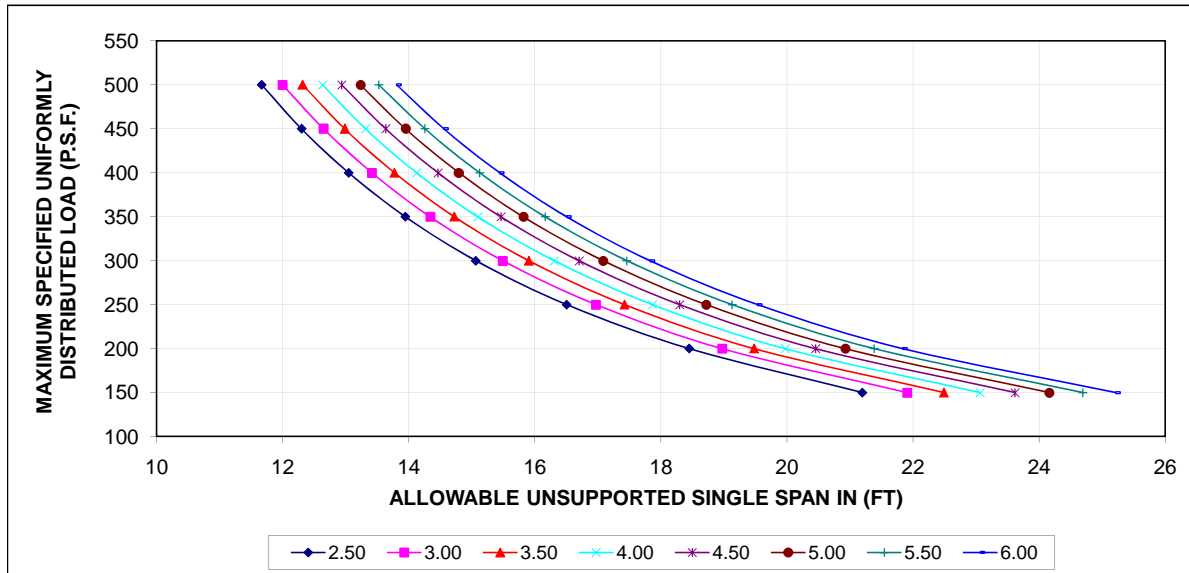



ULTRA-BOND COMPOSITE FLOOR DECK
 MAXIMUM SPECIFIED UNIFORMLY DISTRIBUTED LOAD (P.S.F)
 INCLUDES DEAD AND CONSTRUCTION LOAD CARRIED
 BY METAL DECK *(NOT SHOWN IN TABLES)*
 LIMIT STATE DESIGN (LSD) - **IMPERIAL UNITS**

0.0476" Deck
0.984" Rebar

INPUT SECTION:

ITEM	DESCRIPTION OR SECTION PROPERTIES	CONCRETE COVER ABOVE TOP OF METAL DECK (hf) OR (hc) (IN)							
		2.50	3.00	3.50	4.00	4.50	5.00	5.50	6.00
A	METAL DECK THICK (INCH) (Td)	0.0476	0.0476	0.0476	0.0476	0.0476	0.0476	0.0476	0.0476
B	METAL DECK YIELD STRENGTH (KSI)(Fy)	40.6	40.6	40.6	40.6	40.6	40.6	40.6	40.6
C	METAL DECK EFF. (Ix) (IN ⁴)/FT	5.09	5.09	5.09	5.09	5.09	5.09	5.09	5.09
D	METAL DECK EFF. (Sx) (IN ³)/FT	1.15	1.15	1.15	1.15	1.15	1.15	1.15	1.15
E	METAL DECK (Es)(PSI)	2.95E+07	2.95E+07	2.95E+07	2.95E+07	2.95E+07	2.95E+07	2.95E+07	2.95E+07
F	# REINFORCING STEEL BAR DIA. (INCH)	0.984	0.984	0.984	0.984	0.984	0.984	0.984	0.984
G	CONCRETE STRENGTH (f'c) (PSI)	4350	4350	4350	4350	4350	4350	4350	4350
H	CONCRETE (Ec) (PSI)	3.80E+06	3.80E+06	3.80E+06	3.80E+06	3.80E+06	3.80E+06	3.80E+06	3.80E+06
I	A _F (IN ²)/FT	0.865	0.865	0.865	0.865	0.865	0.865	0.865	0.865
J	I _{x(F)} (IN ⁴)/FT	7.18	7.18	7.18	7.18	7.18	7.18	7.18	7.18
K	ALLOWABLE FORCE (LBS/FT)	659	659	659	659	659	659	659	659
L	FINAL EFF. CROSS SECT. AREA A _{SO} (IN ²)	0.900	0.900	0.900	0.900	0.900	0.900	0.900	0.900
M	DEFLECTION CRITERIA K _{1,2,3,4}	1.333	1.333	1.333	1.333	1.333	1.333	1.333	1.333
N	DEFLECTION CRITERIA *	L/480	L/480	L/480	L/480	L/480	L/480	L/480	L/480

* DEFLECTION CRITERIA: L/360 (K₁=1), L/480 (K₂=1.333), L/600 (K₃=1.670) OR L/720 (K₄=2.0)
 # REINFORCING BAR Fy0=58.0KSI

OUTPUT SECTION #1

ITEM	DESCRIPTION	CONCRETE COVER ABOVE TOP OF METAL DECK (hf) OR (hc) (IN)							
		2.50	3.00	3.50	4.00	4.50	5.00	5.50	6.00
O	MAX. UNSHORED SPAN (C.L.21PSF).FT.	14.10	13.01	12.08	11.27	10.57	9.94	9.39	8.90
P	MAX. UNSHORED SPAN (C.L.42PSF).FT.	9.49	9.42	9.21	9.11	8.73	8.30	7.91	7.56
Q	TOTAL DEAD LOAD (NO CONST.).PSF.	53.79	60.04	66.29	72.54	78.78	85.03	91.28	97.53
R	CONCRETE VOLUME. YD ³ /100FT ²	1.224	1.378	1.532	1.686	1.841	1.995	2.149	2.303

C.L. = CONSTRUCTION LOAD (PSF)

OUTPUT SECTION #2: PLOT DATA - AND INPUT SECTION AS SHOWN #

ITEM	DESCRIPTION	(hf) OR (hc) (IN)	# MAXIMUM SPECIFIED UNIFORMLY DISTRIBUTED LOAD (P.S.F)							
			150	200	250	300	350	400	450	500
1	ALLOW. SINGLE UNSUP. SPAN - FT.	2.50	21.39	19.43	18.04	16.98	16.07	15.03	14.17	13.45
2	ALLOW. SINGLE UNSUP. SPAN - FT.	3.00	22.50	20.44	18.98	17.85	16.53	15.46	14.58	13.83
3	ALLOW. SINGLE UNSUP. SPAN - FT.	3.50	23.61	21.45	19.92	18.33	16.97	15.88	14.97	14.20
4	ALLOW. SINGLE UNSUP. SPAN - FT.	4.00	24.72	22.47	20.60	18.80	17.41	16.28	15.35	14.56
5	ALLOW. SINGLE UNSUP. SPAN - FT.	4.50	25.84	23.48	21.10	19.26	17.83	16.68	15.72	14.92
6	ALLOW. SINGLE UNSUP. SPAN - FT.	5.00	26.96	24.13	21.59	19.71	18.24	17.07	16.09	15.26
7	ALLOW. SINGLE UNSUP. SPAN - FT.	5.50	28.09	24.67	22.06	20.14	18.65	17.44	16.45	15.60
8	ALLOW. SINGLE UNSUP. SPAN - FT.	6.00	29.09	25.19	22.53	20.57	19.04	17.81	16.80	15.93

Figures shown in yellow to be multiplied by a factor of 0.9 - See Manual (Creep Stress)

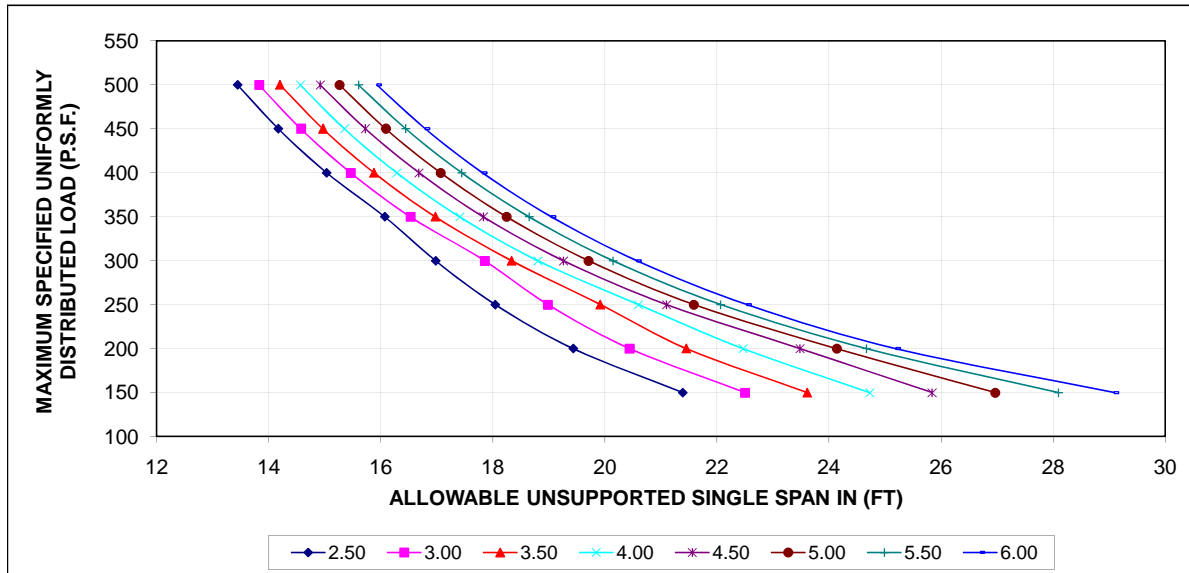



ULTRA-BOND COMPOSITE FLOOR DECK
 MAXIMUM SPECIFIED UNIFORMLY DISTRIBUTED LOAD (P.S.F)
 INCLUDES DEAD AND CONSTRUCTION LOAD CARRIED
 BY METAL DECK *(NOT SHOWN IN TABLES)*
 LIMIT STATE DESIGN (LSD) - IMPERIAL UNITS

0.0476" Deck
1.181" Rebar

INPUT SECTION:

ITEM	DESCRIPTION OR SECTION PROPERTIES	CONCRETE COVER ABOVE TOP OF METAL DECK (hf) OR (hc) (IN)							
		2.50	3.00	3.50	4.00	4.50	5.00	5.50	6.00
A	METAL DECK THICK (INCH) (Td)	0.0476	0.0476	0.0476	0.0476	0.0476	0.0476	0.0476	0.0476
B	METAL DECK YIELD STRENGTH (KSI)(Fy)	40.6	40.6	40.6	40.6	40.6	40.6	40.6	40.6
C	METAL DECK EFF. (Ix) (IN ⁴)/FT	5.09	5.09	5.09	5.09	5.09	5.09	5.09	5.09
D	METAL DECK EFF. (Sx) (IN ³)/FT	1.15	1.15	1.15	1.15	1.15	1.15	1.15	1.15
E	METAL DECK (Es)(PSI)	2.95E+07	2.95E+07	2.95E+07	2.95E+07	2.95E+07	2.95E+07	2.95E+07	2.95E+07
F	# REINFORCING STEEL BAR DIA. (INCH)	1.181	1.181	1.181	1.181	1.181	1.181	1.181	1.181
G	CONCRETE STRENGTH (f'c) (PSI)	4350	4350	4350	4350	4350	4350	4350	4350
H	CONCRETE (Ec) (PSI)	3.80E+06	3.80E+06	3.80E+06	3.80E+06	3.80E+06	3.80E+06	3.80E+06	3.80E+06
I	A _F (IN ²)/FT	0.865	0.865	0.865	0.865	0.865	0.865	0.865	0.865
J	I _{x(F)} (IN ⁴)/FT	7.18	7.18	7.18	7.18	7.18	7.18	7.18	7.18
K	ALLOWABLE FORCE (LBS/FT)	659	659	659	659	659	659	659	659
L	FINAL EFF. CROSS SECT. AREA A _{SO} (IN ²)	1.095	1.095	1.095	1.095	1.095	1.095	1.095	1.095
M	DEFLECTION CRITERIA K _{1,2,3,4}	1.333	1.333	1.333	1.333	1.333	1.333	1.333	1.333
N	DEFLECTION CRITERIA *	L/480	L/480	L/480	L/480	L/480	L/480	L/480	L/480

* DEFLECTION CRITERIA: L/360 (K₁=1), L/480 (K₂=1.333), L/600 (K₃=1.670) OR L/720 (K₄=2.0)
 # REINFORCING BAR Fy0=58.0KSI

OUTPUT SECTION #1

ITEM	DESCRIPTION	CONCRETE COVER ABOVE TOP OF METAL DECK (hf) OR (hc) (IN)							
		2.50	3.00	3.50	4.00	4.50	5.00	5.50	6.00
O	MAX. UNSHORED SPAN (C.L.21PSF).FT.	14.06	12.98	12.05	11.25	10.54	9.92	9.37	8.88
P	MAX. UNSHORED SPAN (C.L.42PSF).FT.	9.50	9.44	9.19	9.14	8.71	8.29	7.90	7.55
Q	TOTAL DEAD LOAD (NO CONST.).PSF.	54.01	60.26	66.51	72.76	79.00	85.25	91.50	97.75
R	CONCRETE VOLUME. YD ³ /100FT ²	1.215	1.369	1.524	1.678	1.832	1.986	2.141	2.295

C.L. = CONSTRUCTION LOAD (PSF)

OUTPUT SECTION #2: PLOT DATA - AND INPUT SECTION AS SHOWN #

ITEM	DESCRIPTION	(hf) OR (hc) (IN)	# MAXIMUM SPECIFIED UNIFORMLY DISTRIBUTED LOAD (P.S.F)							
			150	200	250	300	350	400	450	500
1	ALLOW. SINGLE UNSUP. SPAN - FT.	2.50	21.59	19.62	18.22	17.14	16.29	15.58	14.98	14.46
2	ALLOW. SINGLE UNSUP. SPAN - FT.	3.00	22.75	20.67	19.19	18.06	17.16	16.41	15.78	15.20
3	ALLOW. SINGLE UNSUP. SPAN - FT.	3.50	23.91	21.72	20.17	18.98	18.03	17.25	16.46	15.61
4	ALLOW. SINGLE UNSUP. SPAN - FT.	4.00	25.07	22.78	21.15	19.90	18.90	17.90	16.88	16.01
5	ALLOW. SINGLE UNSUP. SPAN - FT.	4.50	26.23	23.83	22.13	20.82	19.61	18.34	17.29	16.41
6	ALLOW. SINGLE UNSUP. SPAN - FT.	5.00	27.39	24.89	23.11	21.67	20.07	18.77	17.70	16.79
7	ALLOW. SINGLE UNSUP. SPAN - FT.	5.50	28.56	25.95	24.10	22.16	20.51	19.19	18.09	17.16
8	ALLOW. SINGLE UNSUP. SPAN - FT.	6.00	29.74	27.02	24.79	22.63	20.95	19.60	18.48	17.53

Figures shown in yellow to be multiplied by a factor of 0.9 - See Manual (Creep Stress)

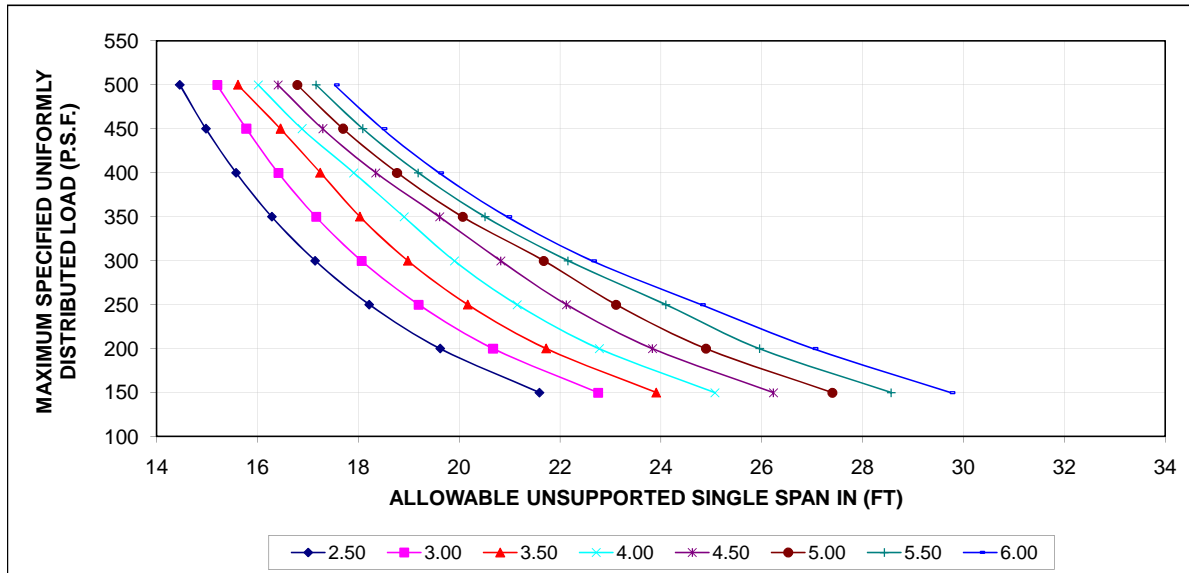



ULTRA-BOND COMPOSITE FLOOR DECK
 MAXIMUM SPECIFIED UNIFORMLY DISTRIBUTED LOAD (P.S.F)
 INCLUDES DEAD AND CONSTRUCTION LOAD CARRIED
 BY METAL DECK *(NOT SHOWN IN TABLES)*
 LIMIT STATE DESIGN (LSD) - **IMPERIAL UNITS**

0.0378' Deck
0.394" Rebar

INPUT SECTION:

ITEM	DESCRIPTION OR SECTION PROPERTIES	CONCRETE COVER ABOVE TOP OF METAL DECK (hf) OR (hc) (IN)							
		2.50	3.00	3.50	4.00	4.50	5.00	5.50	6.00
A	METAL DECK THICK (INCH) (Td)	0.0378	0.0378	0.0378	0.0378	0.0378	0.0378	0.0378	0.0378
B	METAL DECK YIELD STRENGTH (KSI)(Fy)	40.6	40.6	40.6	40.6	40.6	40.6	40.6	40.6
C	METAL DECK EFF. (Ix) (IN ⁴)/FT	3.37	3.37	3.37	3.37	3.37	3.37	3.37	3.37
D	METAL DECK EFF. (Sx) (IN ³)/FT	0.684	0.684	0.684	0.684	0.684	0.684	0.684	0.684
E	METAL DECK (Es)(PSI)	2.95E+07	2.95E+07	2.95E+07	2.95E+07	2.95E+07	2.95E+07	2.95E+07	2.95E+07
F	# REINFORCING STEEL BAR DIA. (INCH)	0.394	0.394	0.394	0.394	0.394	0.394	0.394	0.394
G	CONCRETE STRENGTH (f'c) (PSI)	4350	4350	4350	4350	4350	4350	4350	4350
H	CONCRETE (Ec) (PSI)	3.80E+06	3.80E+06	3.80E+06	3.80E+06	3.80E+06	3.80E+06	3.80E+06	3.80E+06
I	A _F (IN ²)/FT	0.687	0.687	0.687	0.687	0.687	0.687	0.687	0.687
J	I _{X(F)} (IN ⁴)/FT	5.70	5.70	5.70	5.70	5.70	5.70	5.70	5.70
K	ALLOWABLE FORCE (LBS/FT)	437	437	437	437	437	437	437	437
L	FINAL EFF. CROSS SECT. AREA A _{SO} (IN ²)	0.372	0.372	0.372	0.372	0.372	0.372	0.372	0.372
M	DEFLECTION CRITERIA K _{1,2,3,4}	1.000	1.000	1.000	1.000	1.000	1.000	1.000	1.000

* DEFLECTION CRITERIA: L/360 (K₁=1), L/480 (K₂=1.333), L/600 (K₃=1.670) OR L/720 (K₄=2.0)
 # REINFORCING BAR Fy0=58.0KSI

OUTPUT SECTION #1

ITEM	DESCRIPTION	CONCRETE COVER ABOVE TOP OF METAL DECK (hf) OR (hc) (IN)							
		2.50	3.00	3.50	4.00	4.50	5.00	5.50	6.00
O	MAX. UNSHORED SPAN (C.L.21PSF).FT.	9.48	8.74	8.11	7.56	7.08	6.66	6.28	5.95
P	MAX. UNSHORED SPAN (C.L.42PSF).FT.	7.38	6.92	6.52	6.16	5.84	5.55	5.29	5.05
Q	TOTAL DEAD LOAD (NO CONST.).PSF.	52.77	59.01	65.26	71.51	77.76	84.00	90.25	96.50
R	CONCRETE VOLUME. YD ³ /100FT ²	1.240	1.394	1.549	1.703	1.857	2.011	2.166	2.320

C.L. = CONSTRUCTION LOAD (PSF)

OUTPUT SECTION #2: PLOT DATA - AND INPUT SECTION AS SHOWN #

ITEM	DESCRIPTION	(hf) OR (hc) (IN)	# MAXIMUM SPECIFIED UNIFORMLY DISTRIBUTED LOAD (P.S.F)							
			150	200	250	300	350	400	450	500
1	ALLOW. SINGLE UNSUP. SPAN - FT.	2.50	15.95	13.81	12.35	11.28	10.44	9.77	9.21	8.73
2	ALLOW. SINGLE UNSUP. SPAN - FT.	3.00	16.39	14.20	12.70	11.59	10.73	10.04	9.46	8.98
3	ALLOW. SINGLE UNSUP. SPAN - FT.	3.50	16.83	14.57	13.03	11.90	11.01	10.30	9.71	9.22
4	ALLOW. SINGLE UNSUP. SPAN - FT.	4.00	17.25	14.94	13.36	12.20	11.29	10.56	9.96	9.45
5	ALLOW. SINGLE UNSUP. SPAN - FT.	4.50	17.66	15.29	13.68	12.49	11.56	10.81	10.20	9.67
6	ALLOW. SINGLE UNSUP. SPAN - FT.	5.00	18.06	15.64	13.99	12.77	11.82	11.06	10.43	9.89
7	ALLOW. SINGLE UNSUP. SPAN - FT.	5.50	18.46	15.98	14.30	13.05	12.08	11.30	10.66	10.11
8	ALLOW. SINGLE UNSUP. SPAN - FT.	6.00	18.84	16.32	14.59	13.32	12.33	11.54	10.88	10.32

FIGURES TO BE MULTIPLIED BY (0.9) - SHOWN IN YELLOW - SEE MANUAL (CREEP STRESS)

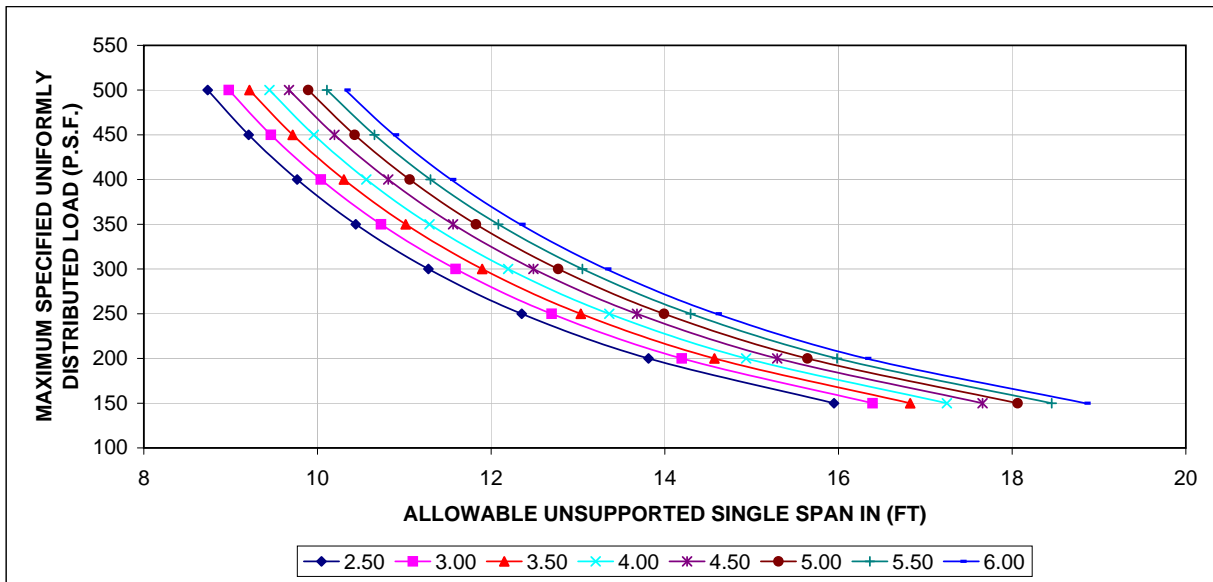



ULTRA-BOND COMPOSITE FLOOR DECK
 MAXIMUM SPECIFIED UNIFORMLY DISTRIBUTED LOAD (P.S.F)
 INCLUDES DEAD AND CONSTRUCTION LOAD CARRIED
 BY METAL DECK *(NOT SHOWN IN TABLES)*
 LIMIT STATE DESIGN (LSD) - **IMPERIAL UNITS**

0.0378" Deck
0.591" Rebar

INPUT SECTION:

ITEM	DESCRIPTION OR SECTION PROPERTIES	CONCRETE COVER ABOVE TOP OF METAL DECK (hf) OR (hc) (IN)							
		2.50	3.00	3.50	4.00	4.50	5.00	5.50	6.00
A	METAL DECK THICK (INCH) (Td)	0.0378	0.0378	0.0378	0.0378	0.0378	0.0378	0.0378	0.0378
B	METAL DECK YIELD STRENGTH (KSI)(Fy)	40.6	40.6	40.6	40.6	40.6	40.6	40.6	40.6
C	METAL DECK EFF. (Ix) (IN ⁴)/FT	3.37	3.37	3.37	3.37	3.37	3.37	3.37	3.37
D	METAL DECK EFF. (Sx) (IN ³)/FT	0.684	0.684	0.684	0.684	0.684	0.684	0.684	0.684
E	METAL DECK (Es)(PSI)	2.95E+07	2.95E+07	2.95E+07	2.95E+07	2.95E+07	2.95E+07	2.95E+07	2.95E+07
F	# REINFORCING STEEL BAR DIA. (INCH)	0.591	0.591	0.591	0.591	0.591	0.591	0.591	0.591
G	CONCRETE STRENGTH (f'c) (PSI)	4350	4350	4350	4350	4350	4350	4350	4350
H	CONCRETE (Ec) (PSI)	3.80E+06	3.80E+06	3.80E+06	3.80E+06	3.80E+06	3.80E+06	3.80E+06	3.80E+06
I	A _F (IN ²)/FT	0.687	0.687	0.687	0.687	0.687	0.687	0.687	0.687
J	I _{X(F)} (IN ⁴)/FT	5.70	5.70	5.70	5.70	5.70	5.70	5.70	5.70
K	ALLOWABLE FORCE (LBS/FT)	437	437	437	437	437	437	437	437
L	FINAL EFF. CROSS SECT. AREA A _{SO} (IN ²)	0.500	0.500	0.500	0.500	0.500	0.500	0.500	0.500
M	DEFLECTION CRITERIA K _{1,2,3,4}	1.000	1.000	1.000	1.000	1.000	1.000	1.000	1.000

* DEFLECTION CRITERIA: L/360 (K₁=1), L/480 (K₂=1.333), L/600 (K₃=1.670) OR L/720 (K₄=2.0)
 # REINFORCING BAR Fy0=58.0KSI

OUTPUT SECTION #1

ITEM	DESCRIPTION	CONCRETE COVER ABOVE TOP OF METAL DECK (hf) OR (hc) (IN)							
		2.50	3.00	3.50	4.00	4.50	5.00	5.50	6.00
O	MAX. UNSHORED SPAN (C.L.21PSF).FT.	9.47	8.73	8.10	7.55	7.07	6.65	6.28	5.95
P	MAX. UNSHORED SPAN (C.L.42PSF).FT.	7.37	6.92	6.51	6.15	5.83	5.54	5.28	5.04
Q	TOTAL DEAD LOAD (NO CONST.).PSF.	52.87	59.11	65.36	71.61	77.86	84.10	90.35	96.60
R	CONCRETE VOLUME. YD ³ /100FT ²	1.236	1.390	1.545	1.699	1.853	2.007	2.162	2.316

C.L. = CONSTRUCTION LOAD (PSF)

OUTPUT SECTION #2: PLOT DATA - AND INPUT SECTION AS SHOWN #

ITEM	DESCRIPTION	(hf) OR (hc) (IN)	# MAXIMUM SPECIFIED UNIFORMLY DISTRIBUTED LOAD (P.S.F)							
			150	200	250	300	350	400	450	500
1	ALLOW. SINGLE UNSUP. SPAN - FT.	2.50	18.45	15.97	14.29	13.04	12.08	11.30	10.65	10.10
2	ALLOW. SINGLE UNSUP. SPAN - FT.	3.00	18.96	16.42	14.69	13.41	12.41	11.61	10.95	10.39
3	ALLOW. SINGLE UNSUP. SPAN - FT.	3.50	19.47	16.86	15.08	13.76	12.74	11.92	11.24	10.66
4	ALLOW. SINGLE UNSUP. SPAN - FT.	4.00	19.96	17.28	15.46	14.11	13.06	12.22	11.52	10.93
5	ALLOW. SINGLE UNSUP. SPAN - FT.	4.50	20.43	17.70	15.83	14.45	13.38	12.51	11.80	11.19
6	ALLOW. SINGLE UNSUP. SPAN - FT.	5.00	20.90	18.10	16.19	14.78	13.68	12.80	12.07	11.45
7	ALLOW. SINGLE UNSUP. SPAN - FT.	5.50	21.36	18.50	16.54	15.10	13.98	13.08	12.33	11.70
8	ALLOW. SINGLE UNSUP. SPAN - FT.	6.00	21.81	18.89	16.89	15.42	14.28	13.35	12.59	11.94

FIGURES TO BE MULTIPLIED BY (0.9) - SHOWN IN YELLOW - SEE MANUAL (CREEP STRESS)

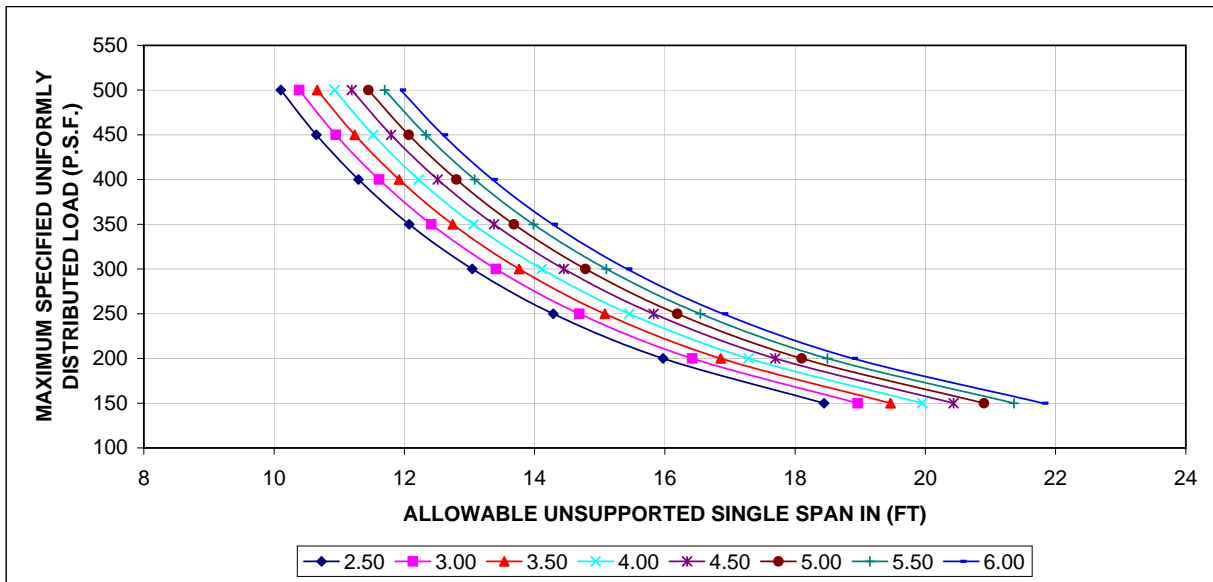



ULTRA-BOND COMPOSITE FLOOR DECK
 MAXIMUM SPECIFIED UNIFORMLY DISTRIBUTED LOAD (P.S.F)
 INCLUDES DEAD AND CONSTRUCTION LOAD CARRIED
 BY METAL DECK *(NOT SHOWN IN TABLES)*
 LIMIT STATE DESIGN (LSD) - **IMPERIAL UNITS**

0.0378" Deck
0.787" Rebar

INPUT SECTION:

ITEM	DESCRIPTION OR SECTION PROPERTIES	CONCRETE COVER ABOVE TOP OF METAL DECK (hf) OR (hc) (IN)							
		2.50	3.00	3.50	4.00	4.50	5.00	5.50	6.00
A	METAL DECK THICK (INCH) (Td)	0.0378	0.0378	0.0378	0.0378	0.0378	0.0378	0.0378	0.0378
B	METAL DECK YIELD STRENGTH (KSI)(Fy)	40.6	40.6	40.6	40.6	40.6	40.6	40.6	40.6
C	METAL DECK EFF. (Ix) (IN ⁴)/FT	3.37	3.37	3.37	3.37	3.37	3.37	3.37	3.37
D	METAL DECK EFF. (Sx) (IN ³)/FT	0.684	0.684	0.684	0.684	0.684	0.684	0.684	0.684
E	METAL DECK (Es)(PSI)	2.95E+07	2.95E+07	2.95E+07	2.95E+07	2.95E+07	2.95E+07	2.95E+07	2.95E+07
F	# REINFORCING STEEL BAR DIA. (INCH)	0.787	0.787	0.787	0.787	0.787	0.787	0.787	0.787
G	CONCRETE STRENGTH (f'c) (PSI)	4350	4350	4350	4350	4350	4350	4350	4350
H	CONCRETE (Ec) (PSI)	3.80E+06	3.80E+06	3.80E+06	3.80E+06	3.80E+06	3.80E+06	3.80E+06	3.80E+06
I	A _F (IN ²)/FT	0.687	0.687	0.687	0.687	0.687	0.687	0.687	0.687
J	I _{X(F)} (IN ⁴)/FT	5.70	5.70	5.70	5.70	5.70	5.70	5.70	5.70
K	ALLOWABLE FORCE (LBS/FT)	437	437	437	437	437	437	437	437
L	FINAL EFF. CROSS SECT. AREA A _{SO} (IN ²)	0.560	0.560	0.560	0.560	0.560	0.560	0.560	0.560
M	DEFLECTION CRITERIA K _{1,2,3,4}	1.000	1.000	1.000	1.000	1.000	1.000	1.000	1.000

* DEFLECTION CRITERIA: L/360 (K₁=1), L/480 (K₂=1.333), L/600 (K₃=1.670) OR L/720 (K₄=2.0)
 # REINFORCING BAR Fy0=58.0KSI

OUTPUT SECTION #1

ITEM	DESCRIPTION	CONCRETE COVER ABOVE TOP OF METAL DECK (hf) OR (hc) (IN)							
		2.50	3.00	3.50	4.00	4.50	5.00	5.50	6.00
O	MAX. UNSHORED SPAN (C.L.21PSF).FT.	9.45	8.71	8.08	7.54	7.06	6.64	6.27	5.94
P	MAX. UNSHORED SPAN (C.L.42PSF).FT.	7.36	6.91	6.50	6.15	5.83	5.54	5.28	5.04
Q	TOTAL DEAD LOAD (NO CONST.).PSF.	53.01	59.25	65.50	71.75	78.00	84.24	90.49	96.74
R	CONCRETE VOLUME. YD ³ /100FT ²	1.231	1.385	1.539	1.693	1.848	2.002	2.156	2.310

C.L. = CONSTRUCTION LOAD (PSF)

OUTPUT SECTION #2: PLOT DATA - AND INPUT SECTION AS SHOWN #

ITEM	DESCRIPTION	(hf) OR (hc) (IN)	# MAXIMUM SPECIFIED UNIFORMLY DISTRIBUTED LOAD (P.S.F)							
			150	200	250	300	350	400	450	500
1	ALLOW. SINGLE UNSUP. SPAN - FT.	2.50	19.50	16.89	15.10	13.79	12.76	11.94	11.26	10.68
2	ALLOW. SINGLE UNSUP. SPAN - FT.	3.00	20.05	17.36	15.53	14.17	13.12	12.28	11.57	10.98
3	ALLOW. SINGLE UNSUP. SPAN - FT.	3.50	20.58	17.82	15.94	14.55	13.47	12.60	11.88	11.27
4	ALLOW. SINGLE UNSUP. SPAN - FT.	4.00	21.10	18.27	16.34	14.92	13.81	12.92	12.18	11.56
5	ALLOW. SINGLE UNSUP. SPAN - FT.	4.50	21.61	18.71	16.74	15.28	14.14	13.23	12.47	11.83
6	ALLOW. SINGLE UNSUP. SPAN - FT.	5.00	22.10	19.14	17.12	15.63	14.47	13.53	12.76	12.11
7	ALLOW. SINGLE UNSUP. SPAN - FT.	5.50	22.59	19.56	17.49	15.97	14.79	13.83	13.04	12.37
8	ALLOW. SINGLE UNSUP. SPAN - FT.	6.00	23.06	19.97	17.86	16.31	15.10	14.12	13.31	12.63

FIGURES TO BE MULTIPLIED BY (0.9) - SHOWN IN YELLOW - SEE MANUAL (CREEP STRESS)

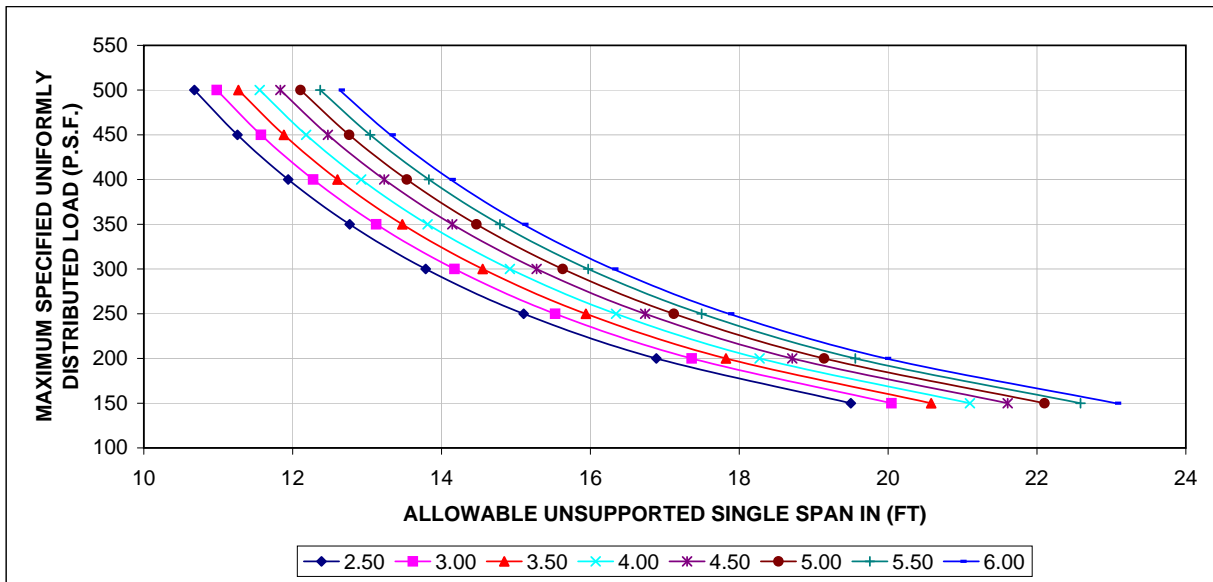



ULTRA-BOND COMPOSITE FLOOR DECK
 MAXIMUM SPECIFIED UNIFORMLY DISTRIBUTED LOAD (P.S.F)
 INCLUDES DEAD AND CONSTRUCTION LOAD CARRIED
 BY METAL DECK *(NOT SHOWN IN TABLES)*
 LIMIT STATE DESIGN (LSD) - IMPERIAL UNITS

0.0378" Deck
0.984" Rebar

INPUT SECTION:

ITEM	DESCRIPTION OR SECTION PROPERTIES	CONCRETE COVER ABOVE TOP OF METAL DECK (hf) OR (hc) (IN)							
		2.50	3.00	3.50	4.00	4.50	5.00	5.50	6.00
A	METAL DECK THICK (INCH) (Td)	0.0378	0.0378	0.0378	0.0378	0.0378	0.0378	0.0378	0.0378
B	METAL DECK YIELD STRENGTH (KSI)(Fy)	40.6	40.6	40.6	40.6	40.6	40.6	40.6	40.6
C	METAL DECK EFF. (Ix) (IN ⁴)/FT	3.37	3.37	3.37	3.37	3.37	3.37	3.37	3.37
D	METAL DECK EFF. (Sx) (IN ³)/FT	0.684	0.684	0.684	0.684	0.684	0.684	0.684	0.684
E	METAL DECK (Es)(PSI)	2.95E+07	2.95E+07	2.95E+07	2.95E+07	2.95E+07	2.95E+07	2.95E+07	2.95E+07
F	# REINFORCING STEEL BAR DIA. (INCH)	0.984	0.984	0.984	0.984	0.984	0.984	0.984	0.984
G	CONCRETE STRENGTH (f'c) (PSI)	4350	4350	4350	4350	4350	4350	4350	4350
H	CONCRETE (Ec) (PSI)	3.80E+06	3.80E+06	3.80E+06	3.80E+06	3.80E+06	3.80E+06	3.80E+06	3.80E+06
I	A _F (IN ²)/FT	0.687	0.687	0.687	0.687	0.687	0.687	0.687	0.687
J	I _{X(F)} (IN ⁴)/FT	5.70	5.70	5.70	5.70	5.70	5.70	5.70	5.70
K	ALLOWABLE FORCE (LBS/FT)	437	437	437	437	437	437	437	437
L	FINAL EFF. CROSS SECT. AREA A _{SO} (IN ²)	0.760	0.760	0.760	0.760	0.760	0.760	0.760	0.760
M	DEFLECTION CRITERIA K _{1,2,3,4}	1.000	1.000	1.000	1.000	1.000	1.000	1.000	1.000

* DEFLECTION CRITERIA: L/360 (K₁=1), L/480 (K₂=1.333), L/600 (K₃=1.670) OR L/720 (K₄=2.0)
 # REINFORCING BAR Fy0=58.0KSI

OUTPUT SECTION #1

ITEM	DESCRIPTION	CONCRETE COVER ABOVE TOP OF METAL DECK (hf) OR (hc) (IN)							
		2.50	3.00	3.50	4.00	4.50	5.00	5.50	6.00
O	MAX. UNSHORED SPAN (C.L.21PSF).FT.	9.42	8.69	8.07	7.52	7.05	6.63	6.26	5.93
P	MAX. UNSHORED SPAN (C.L.42PSF).FT.	7.35	6.89	6.49	6.14	5.82	5.53	5.27	5.03
Q	TOTAL DEAD LOAD (NO CONST.).PSF.	53.19	59.43	65.68	71.93	78.18	84.42	90.67	96.92
R	CONCRETE VOLUME. YD ³ /100FT ²	1.224	1.378	1.532	1.686	1.841	1.995	2.149	2.303

C.L. = CONSTRUCTION LOAD (PSF)

OUTPUT SECTION #2: PLOT DATA - AND INPUT SECTION AS SHOWN #

ITEM	DESCRIPTION	(hf) OR (hc) (IN)	# MAXIMUM SPECIFIED UNIFORMLY DISTRIBUTED LOAD (P.S.F)							
			150	200	250	300	350	400	450	500
1	ALLOW. SINGLE UNSUP. SPAN - FT.	2.50	22.63	19.60	17.53	16.00	14.82	13.86	13.07	12.40
2	ALLOW. SINGLE UNSUP. SPAN - FT.	3.00	23.27	20.15	18.03	16.45	15.23	14.25	13.44	12.75
3	ALLOW. SINGLE UNSUP. SPAN - FT.	3.50	23.89	20.69	18.51	16.90	15.64	14.63	13.80	13.09
4	ALLOW. SINGLE UNSUP. SPAN - FT.	4.00	24.50	21.22	18.98	17.32	16.04	15.00	14.15	13.42
5	ALLOW. SINGLE UNSUP. SPAN - FT.	4.50	25.09	21.73	19.44	17.74	16.43	15.37	14.49	13.74
6	ALLOW. SINGLE UNSUP. SPAN - FT.	5.00	25.67	22.23	19.89	18.15	16.81	15.72	14.82	14.06
7	ALLOW. SINGLE UNSUP. SPAN - FT.	5.50	26.24	22.72	20.32	18.55	17.18	16.07	15.15	14.37
8	ALLOW. SINGLE UNSUP. SPAN - FT.	6.00	26.79	23.20	20.75	18.95	17.54	16.41	15.47	14.67

FIGURES TO BE MULTIPLIED BY (0.9) - SHOWN IN YELLOW - SEE MANUAL (CREEP STRESS)

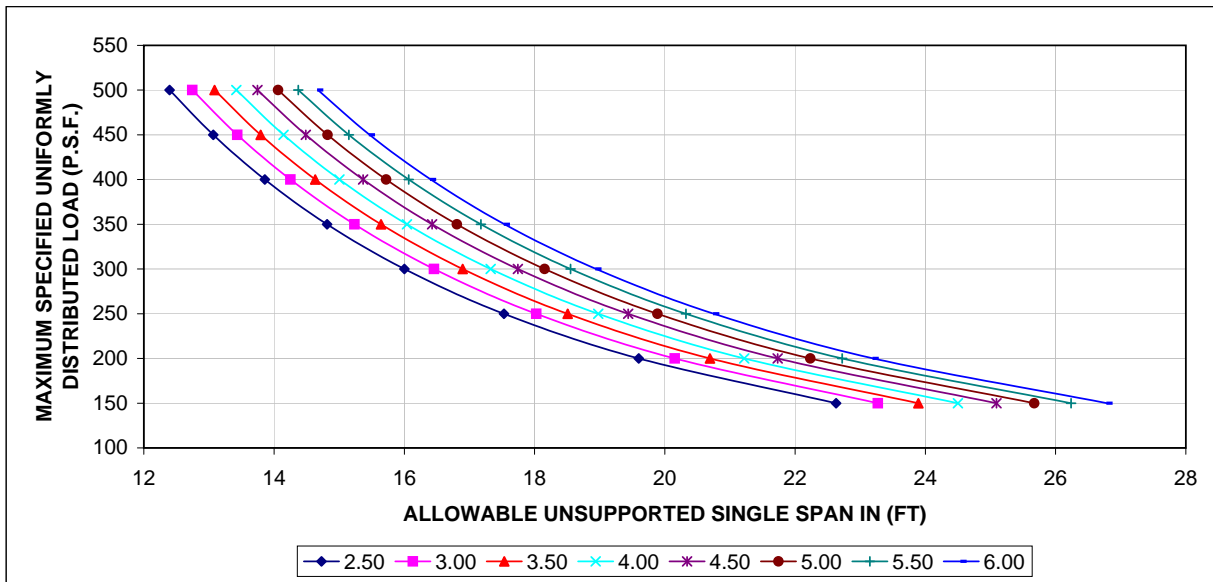



ULTRA-BOND COMPOSITE FLOOR DECK
 MAXIMUM SPECIFIED UNIFORMLY DISTRIBUTED LOAD (KPa)
 INCLUDES DEAD AND CONSTRUCTION LOAD CARRIED
 BY METAL DECK *(NOT SHOWN IN TABLES)*
 LIMIT STATE DESIGN (LSD) -METRIC UNITS

1.21 mm Deck
10 mm Rebar

INPUT SECTION:

ITEM	DESCRIPTION OR SECTION PROPERTIES	CONCRETE COVER ABOVE TOP OF METAL DECK (hf) OR (hc) (mm)							
		63.50	76.20	88.90	101.60	114.30	127.00	139.70	152.40
A	METAL DECK THICK (mm) (Td)	1.21	1.21	1.21	1.21	1.21	1.21	1.21	1.21
B	METAL DECK YIELD STRENGTH (KPa)(Fy)	280	280	280	280	280	280	280	280
C	METAL DECK EFF. (I _x) (mm ⁴)/m	6.95E+06	6.95E+06	6.95E+06	6.95E+06	6.95E+06	6.95E+06	6.95E+06	6.95E+06
D	METAL DECK EFF. (S _x) (mm ³)/m	6.18E+04	6.18E+04	6.18E+04	6.18E+04	6.18E+04	6.18E+04	6.18E+04	6.18E+04
E	METAL DECK (E _s)(KPa)	2.03E+08	2.03E+08	2.03E+08	2.03E+08	2.03E+08	2.03E+08	2.03E+08	2.03E+08
F	# REINFORCING STEEL BAR DIA. (mm)	10	10	10	10	10	10	10	10
G	CONCRETE STRENGTH (f'c) (KPa)	3.00E+04	3.00E+04	3.00E+04	3.00E+04	3.00E+04	3.00E+04	3.00E+04	3.00E+04
H	CONCRETE (E _c) (KPa)	2.62E+07	2.62E+07	2.62E+07	2.62E+07	2.62E+07	2.62E+07	2.62E+07	2.62E+07
I	A _F (mm ²)/m	1830.917	1830.917	1830.917	1830.917	1830.917	1830.917	1830.917	1830.917
J	I _{x(p)} (mm ⁴)/m	9.80E+06	9.80E+06	9.80E+06	9.80E+06	9.80E+06	9.80E+06	9.80E+06	9.80E+06
K	ALLOWABLE FORCE (KN/m)	9.617	9.617	9.617	9.617	9.617	9.617	9.617	9.617
L	FINAL EFF. CROSS SECT. AREA A _{SO} (IN ²)	301	301	301	301	301	301	301	301
M	DEFLECTION CRITERIA K _{1,2,3,4}	1.333	1.333	1.333	1.333	1.333	1.333	1.333	1.333
N	DEFLECTION CRITERIA *	L/480	L/480	L/480	L/480	L/480	L/480	L/480	L/480

* DEFLECTION CRITERIA: L/360 (K₁=1), L/480 (K₂=1.333), L/600 (K₃=1.670) OR L/720 (K₄=2.0)
 # REINFORCING BAR Fy0=400MPa

OUTPUT SECTION #1

ITEM	DESCRIPTION	CONCRETE COVER ABOVE TOP OF METAL DECK (hf) OR (hc) (mm)							
		63.50	76.20	88.90	101.60	114.30	127.00	139.70	152.40
O	MAX. UNSHORED SPAN (C.L.1.006KPa).m.	4.32	3.99	3.70	3.45	3.23	3.04	2.87	2.72
P	MAX. UNSHORED SPAN (C.L.2.011KPa).m.	2.89	2.86	2.82	2.76	2.67	2.54	2.42	2.31
Q	TOTAL DEAD LOAD (NO CONST.)KPa.	2.555	2.855	3.154	3.453	3.752	4.051	4.350	4.649
R	CONCRETE VOLUME. m ³ /10m ²	1.021	1.147	1.274	1.401	1.528	1.655	1.782	1.909

C.L. = CONSTRUCTION LOAD (Pa)

OUTPUT SECTION #2: PLOT DATA - AND INPUT SECTION AS SHOWN #

ITEM	DESCRIPTION	(hf) OR (hc) (mm)	# MAXIMUM SPECIFIED UNIFORMLY DISTRIBUTED LOAD (KPa)							
			7.182	9.576	11.97	14.364	16.758	19.152	21.546	23.94
1	ALLOW. SINGLE UNSUP. SPAN - m.	63.50	5.43	4.71	4.21	3.84	3.56	3.33	3.14	2.98
2	ALLOW. SINGLE UNSUP. SPAN - m.	76.20	5.59	4.84	4.33	3.95	3.66	3.42	3.23	3.06
3	ALLOW. SINGLE UNSUP. SPAN - m.	88.90	5.73	4.97	4.44	4.05	3.75	3.51	3.31	3.14
4	ALLOW. SINGLE UNSUP. SPAN - m.	101.60	5.88	5.09	4.55	4.16	3.85	3.60	3.39	3.22
5	ALLOW. SINGLE UNSUP. SPAN - m.	114.30	6.02	5.21	4.66	4.26	3.94	3.69	3.48	3.30
6	ALLOW. SINGLE UNSUP. SPAN - m.	127.00	6.16	5.33	4.77	4.35	4.03	3.77	3.55	3.37
7	ALLOW. SINGLE UNSUP. SPAN - m.	139.70	6.29	5.45	4.87	4.45	4.12	3.85	3.63	3.45
8	ALLOW. SINGLE UNSUP. SPAN - m.	152.40	6.42	5.56	4.98	4.54	4.21	3.93	3.71	3.52

Figures shown in blue to be multiplied by a factor of 0.9 - See Manual (Creep Stress)

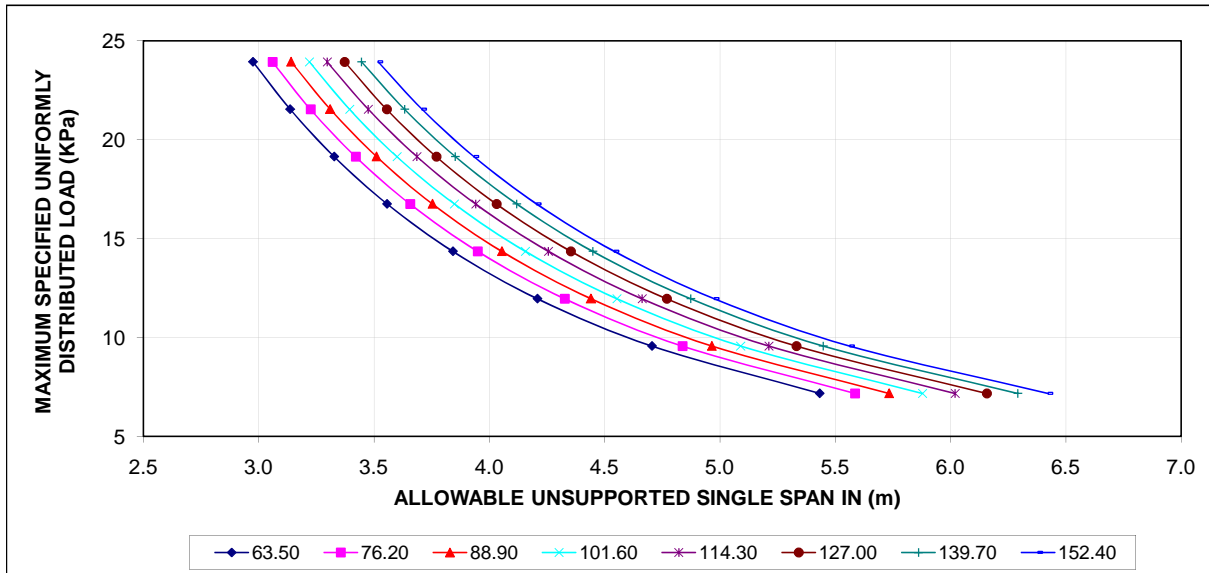



ULTRA-BOND COMPOSITE FLOOR DECK
 MAXIMUM SPECIFIED UNIFORMLY DISTRIBUTED LOAD (KPa)
 INCLUDES DEAD AND CONSTRUCTION LOAD CARRIED
 BY METAL DECK *(NOT SHOWN IN TABLES)*
 LIMIT STATE DESIGN (LSD) -METRIC UNITS

1.21 mm Deck
15 mm Rebar

INPUT SECTION:

ITEM	DESCRIPTION OR SECTION PROPERTIES	CONCRETE COVER ABOVE TOP OF METAL DECK (hf) OR (hc) (mm)							
		63.50	76.20	88.90	101.60	114.30	127.00	139.70	152.40
A	METAL DECK THICK (mm) (Td)	1.21	1.21	1.21	1.21	1.21	1.21	1.21	1.21
B	METAL DECK YIELD STRENGTH (KPa)(Fy)	280	280	280	280	280	280	280	280
C	METAL DECK EFF. (Ix) (mm ⁴ /m)	6.95E+06	6.95E+06	6.95E+06	6.95E+06	6.95E+06	6.95E+06	6.95E+06	6.95E+06
D	METAL DECK EFF. (Sx) (mm ³ /m)	6.18E+04	6.18E+04	6.18E+04	6.18E+04	6.18E+04	6.18E+04	6.18E+04	6.18E+04
E	METAL DECK (Es)(KPa)	2.03E+08	2.03E+08	2.03E+08	2.03E+08	2.03E+08	2.03E+08	2.03E+08	2.03E+08
F	# REINFORCING STEEL BAR DIA. (mm)	15	15	15	15	15	15	15	15
G	CONCRETE STRENGTH (f'c) (KPa)	3.00E+04	3.00E+04	3.00E+04	3.00E+04	3.00E+04	3.00E+04	3.00E+04	3.00E+04
H	CONCRETE (Ec) (KPa)	2.62E+07	2.62E+07	2.62E+07	2.62E+07	2.62E+07	2.62E+07	2.62E+07	2.62E+07
I	A _F (mm ² /m)	1830.917	1830.917	1830.917	1830.917	1830.917	1830.917	1830.917	1830.917
J	I _{x(f)} (mm ⁴ /m)	9.80E+06	9.80E+06	9.80E+06	9.80E+06	9.80E+06	9.80E+06	9.80E+06	9.80E+06
K	ALLOWABLE FORCE (KN/m)	9.617	9.617	9.617	9.617	9.617	9.617	9.617	9.617
L	FINAL EFF. CROSS SECT. AREA A _{SO} (IN ²)	387	387	387	387	387	387	387	387
M	DEFLECTION CRITERIA K _{1,2,3,4}	1.333	1.333	1.333	1.333	1.333	1.333	1.333	1.333
N	DEFLECTION CRITERIA *	L/480	L/480	L/480	L/480	L/480	L/480	L/480	L/480

* DEFLECTION CRITERIA: L/360 (K₁=1), L/480 (K₂=1.333), L/600 (K₃=1.670) OR L/720 (K₄=2.0)
 # REINFORCING BAR Fy0=400MPa

OUTPUT SECTION #1

ITEM	DESCRIPTION	CONCRETE COVER ABOVE TOP OF METAL DECK (hf) OR (hc) (mm)							
		63.50	76.20	88.90	101.60	114.30	127.00	139.70	152.40
O	MAX. UNSHORED SPAN (C.L.1.006KPa).m.	4.32	3.98	3.70	3.45	3.23	3.04	2.87	2.72
P	MAX. UNSHORED SPAN (C.L.2.011KPa).m.	2.89	2.86	2.81	2.77	2.67	2.54	2.42	2.31
Q	TOTAL DEAD LOAD (NO CONST.)KPa.	2.560	2.859	3.158	3.458	3.757	4.056	4.355	4.654
R	CONCRETE VOLUME. m ³ /10m ²	1.017	1.144	1.271	1.398	1.525	1.652	1.779	1.906

C.L. = CONSTRUCTION LOAD (Pa)

OUTPUT SECTION #2: PLOT DATA - AND INPUT SECTION AS SHOWN #

ITEM	DESCRIPTION	(hf) OR (hc) (mm)	# MAXIMUM SPECIFIED UNIFORMLY DISTRIBUTED LOAD (KPa)							
			7.182	9.576	11.97	14.364	16.758	19.152	21.546	23.94
1	ALLOW. SINGLE UNSUP. SPAN - m.	63.50	6.14	5.32	4.76	4.34	4.02	3.76	3.55	3.37
2	ALLOW. SINGLE UNSUP. SPAN - m.	76.20	6.32	5.47	4.89	4.47	4.14	3.87	3.65	3.46
3	ALLOW. SINGLE UNSUP. SPAN - m.	88.90	6.49	5.62	5.02	4.59	4.25	3.97	3.74	3.55
4	ALLOW. SINGLE UNSUP. SPAN - m.	101.60	6.65	5.76	5.15	4.70	4.35	4.07	3.84	3.64
5	ALLOW. SINGLE UNSUP. SPAN - m.	114.30	6.81	5.90	5.27	4.81	4.46	4.17	3.93	3.73
6	ALLOW. SINGLE UNSUP. SPAN - m.	127.00	6.97	6.03	5.40	4.93	4.56	4.27	4.02	3.82
7	ALLOW. SINGLE UNSUP. SPAN - m.	139.70	7.12	6.17	5.51	5.03	4.66	4.36	4.11	3.90
8	ALLOW. SINGLE UNSUP. SPAN - m.	152.40	7.27	6.29	5.63	5.14	4.76	4.45	4.20	3.98

Figures shown in blue to be multiplied by a factor of 0.9 - See Manual (Creep Stress)

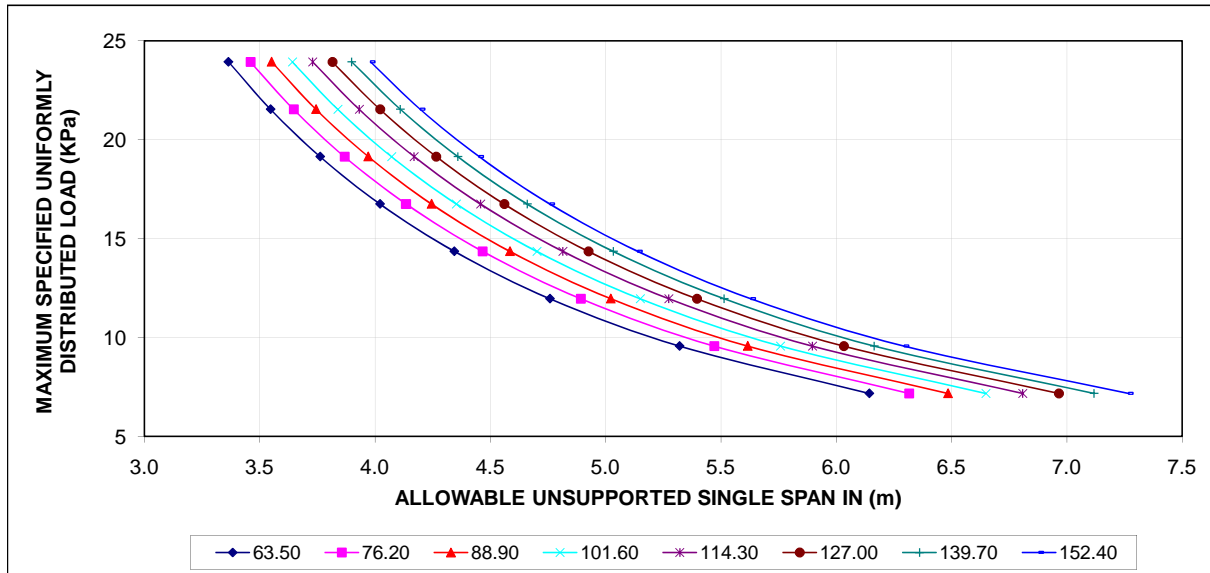



ULTRA-BOND COMPOSITE FLOOR DECK
 MAXIMUM SPECIFIED UNIFORMLY DISTRIBUTED LOAD (KPa)
 INCLUDES DEAD AND CONSTRUCTION LOAD CARRIED
 BY METAL DECK *(NOT SHOWN IN TABLES)*
 LIMIT STATE DESIGN (LSD) -METRIC UNITS

1.21 mm Deck
20 mm Rebar

INPUT SECTION:

ITEM	DESCRIPTION OR SECTION PROPERTIES	CONCRETE COVER ABOVE TOP OF METAL DECK (hf) OR (hc) (mm)							
		63.50	76.20	88.90	101.60	114.30	127.00	139.70	152.40
A	METAL DECK THICK (mm) (Td)	1.21	1.21	1.21	1.21	1.21	1.21	1.21	1.21
B	METAL DECK YIELD STRENGTH (KPa)(Fy)	280	280	280	280	280	280	280	280
C	METAL DECK EFF. (Ix) (mm ⁴)/m	6.95E+06	6.95E+06	6.95E+06	6.95E+06	6.95E+06	6.95E+06	6.95E+06	6.95E+06
D	METAL DECK EFF. (Sx) (mm ³)/m	6.18E+04	6.18E+04	6.18E+04	6.18E+04	6.18E+04	6.18E+04	6.18E+04	6.18E+04
E	METAL DECK (Es)(KPa)	2.03E+08	2.03E+08	2.03E+08	2.03E+08	2.03E+08	2.03E+08	2.03E+08	2.03E+08
F	# REINFORCING STEEL BAR DIA. (mm)	20	20	20	20	20	20	20	20
G	CONCRETE STRENGTH (f'c) (KPa)	3.00E+04	3.00E+04	3.00E+04	3.00E+04	3.00E+04	3.00E+04	3.00E+04	3.00E+04
H	CONCRETE (Ec) (KPa)	2.62E+07	2.62E+07	2.62E+07	2.62E+07	2.62E+07	2.62E+07	2.62E+07	2.62E+07
I	A _F (mm ²)/m	1830.917	1830.917	1830.917	1830.917	1830.917	1830.917	1830.917	1830.917
J	I _{x(f)} (mm ⁴)/m	9.80E+06	9.80E+06	9.80E+06	9.80E+06	9.80E+06	9.80E+06	9.80E+06	9.80E+06
K	ALLOWABLE FORCE (KN/m)	9.617	9.617	9.617	9.617	9.617	9.617	9.617	9.617
L	FINAL EFF. CROSS SECT. AREA A _{SO} (IN ²)	434	434	434	434	434	434	434	434
M	DEFLECTION CRITERIA K _{1,2,3,4}	1.333	1.333	1.333	1.333	1.333	1.333	1.333	1.333
N	DEFLECTION CRITERIA *	L/480	L/480	L/480	L/480	L/480	L/480	L/480	L/480

* DEFLECTION CRITERIA: L/360 (K₁=1), L/480 (K₂=1.333), L/600 (K₃=1.670) OR L/720 (K₄=2.0)
 # REINFORCING BAR Fy0=400MPa

OUTPUT SECTION #1

ITEM	DESCRIPTION	CONCRETE COVER ABOVE TOP OF METAL DECK (hf) OR (hc) (mm)							
		63.50	76.20	88.90	101.60	114.30	127.00	139.70	152.40
O	MAX. UNSHORED SPAN (C.L.1.006KPa).m.	4.31	3.97	3.69	3.44	3.23	3.04	2.87	2.72
P	MAX. UNSHORED SPAN (C.L.2.011KPa).m.	2.89	2.87	2.81	2.77	2.66	2.53	2.41	2.31
Q	TOTAL DEAD LOAD (NO CONST.) KPa.	2.567	2.866	3.165	3.464	3.763	4.063	4.362	4.661
R	CONCRETE VOLUME. m ³ /10m ²	1.013	1.140	1.267	1.394	1.521	1.648	1.775	1.901

C.L. = CONSTRUCTION LOAD (Pa)

OUTPUT SECTION #2: PLOT DATA - AND INPUT SECTION AS SHOWN #

ITEM	DESCRIPTION	(hf) OR (hc) (mm)	# MAXIMUM SPECIFIED UNIFORMLY DISTRIBUTED LOAD (KPa)								
			7.182	9.576	11.97	14.364	16.758	19.152	21.546	23.94	
1	ALLOW. SINGLE UNSUP. SPAN - m.	63.50	6.46	5.62	5.03	4.59	4.25	3.98	3.75	3.56	
2	ALLOW. SINGLE UNSUP. SPAN - m.	76.20	6.68	5.78	5.17	4.72	4.37	4.09	3.85	3.66	
3	ALLOW. SINGLE UNSUP. SPAN - m.	88.90	6.85	5.94	5.31	4.85	4.49	4.20	3.96	3.75	
4	ALLOW. SINGLE UNSUP. SPAN - m.	101.60	7.03	6.09	5.44	4.97	4.60	4.30	4.06	3.85	
5	ALLOW. SINGLE UNSUP. SPAN - m.	114.30	7.20	6.23	5.58	5.09	4.71	4.41	4.16	3.94	
6	ALLOW. SINGLE UNSUP. SPAN - m.	127.00	7.36	6.38	5.70	5.21	4.82	4.51	4.25	4.03	
7	ALLOW. SINGLE UNSUP. SPAN - m.	139.70	7.53	6.52	5.83	5.32	4.93	4.61	4.35	4.12	
8	ALLOW. SINGLE UNSUP. SPAN - m.	152.40	7.69	6.66	5.95	5.43	5.03	4.71	4.44	4.21	

Figures shown in blue to be multiplied by a factor of 0.9 - See Manual (Creep Stress)

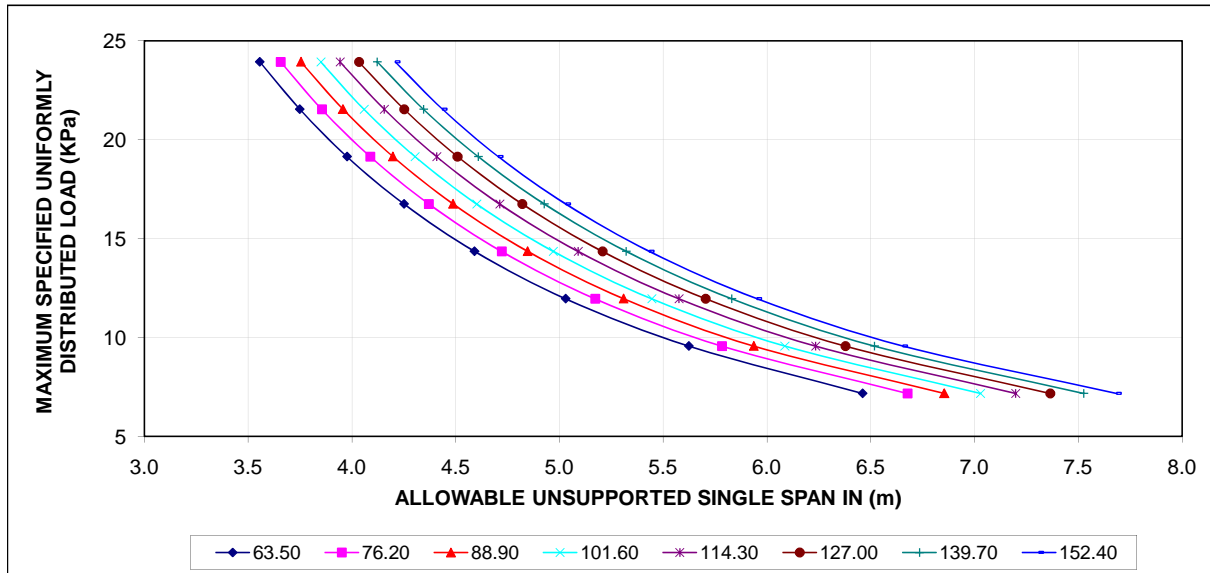



ULTRA-BOND COMPOSITE FLOOR DECK
 MAXIMUM SPECIFIED UNIFORMLY DISTRIBUTED LOAD (KPa)
 INCLUDES DEAD AND CONSTRUCTION LOAD CARRIED
 BY METAL DECK *(NOT SHOWN IN TABLES)*
 LIMIT STATE DESIGN (LSD) -METRIC UNITS

1.21 mm Deck
25 mm Rebar

INPUT SECTION:

ITEM	DESCRIPTION OR SECTION PROPERTIES	CONCRETE COVER ABOVE TOP OF METAL DECK (hf) OR (hc) (mm)							
		63.50	76.20	88.90	101.60	114.30	127.00	139.70	152.40
A	METAL DECK THICK (mm) (Td)	1.21	1.21	1.21	1.21	1.21	1.21	1.21	1.21
B	METAL DECK YIELD STRENGTH (KPa)(Fy)	280	280	280	280	280	280	280	280
C	METAL DECK EFF. (Ix) (mm ⁴ /m)	6.95E+06	6.95E+06	6.95E+06	6.95E+06	6.95E+06	6.95E+06	6.95E+06	6.95E+06
D	METAL DECK EFF. (Sx) (mm ³ /m)	6.18E+04	6.18E+04	6.18E+04	6.18E+04	6.18E+04	6.18E+04	6.18E+04	6.18E+04
E	METAL DECK (Es)(KPa)	2.03E+08	2.03E+08	2.03E+08	2.03E+08	2.03E+08	2.03E+08	2.03E+08	2.03E+08
F	# REINFORCING STEEL BAR DIA. (mm)	25	25	25	25	25	25	25	25
G	CONCRETE STRENGTH (f'c) (KPa)	3.00E+04	3.00E+04	3.00E+04	3.00E+04	3.00E+04	3.00E+04	3.00E+04	3.00E+04
H	CONCRETE (Ec) (KPa)	2.62E+07	2.62E+07	2.62E+07	2.62E+07	2.62E+07	2.62E+07	2.62E+07	2.62E+07
I	A _F (mm ² /m)	1830.917	1830.917	1830.917	1830.917	1830.917	1830.917	1830.917	1830.917
J	I _{x(f)} (mm ⁴ /m)	9.80E+06	9.80E+06	9.80E+06	9.80E+06	9.80E+06	9.80E+06	9.80E+06	9.80E+06
K	ALLOWABLE FORCE (KN/m)	9.617	9.617	9.617	9.617	9.617	9.617	9.617	9.617
L	FINAL EFF. CROSS SECT. AREA A _{SO} (IN ²)	581	581	581	581	581	581	581	581
M	DEFLECTION CRITERIA K _{1,2,3,4}	1.333	1.333	1.333	1.333	1.333	1.333	1.333	1.333
N	DEFLECTION CRITERIA *	L/480	L/480	L/480	L/480	L/480	L/480	L/480	L/480

* DEFLECTION CRITERIA: L/360 (K₁=1), L/480 (K₂=1.333), L/600 (K₃=1.670) OR L/720 (K₄=2.0)
 # REINFORCING BAR Fy0=400MPa

OUTPUT SECTION #1

ITEM	DESCRIPTION	CONCRETE COVER ABOVE TOP OF METAL DECK (hf) OR (hc) (mm)							
		63.50	76.20	88.90	101.60	114.30	127.00	139.70	152.40
O	MAX. UNSHORED SPAN (C.L.1.006KPa).m.	4.30	3.97	3.68	3.44	3.22	3.03	2.86	2.71
P	MAX. UNSHORED SPAN (C.L.2.011KPa).m.	2.89	2.87	2.81	2.78	2.66	2.53	2.41	2.30
Q	TOTAL DEAD LOAD (NO CONST.) KPa.	2.576	2.875	3.174	3.473	3.772	4.071	4.370	4.670
R	CONCRETE VOLUME. m ³ /10m ²	1.007	1.134	1.261	1.388	1.515	1.642	1.769	1.896

C.L. = CONSTRUCTION LOAD (Pa)

OUTPUT SECTION #2: PLOT DATA - AND INPUT SECTION AS SHOWN #

ITEM	DESCRIPTION	(hf) OR (hc) (mm)	# MAXIMUM SPECIFIED UNIFORMLY DISTRIBUTED LOAD (KPa)							
			7.182	9.576	11.97	14.364	16.758	19.152	21.546	23.94
1	ALLOW. SINGLE UNSUP. SPAN - m.	63.50	6.52	5.92	5.50	5.18	4.90	4.58	4.32	4.10
2	ALLOW. SINGLE UNSUP. SPAN - m.	76.20	6.86	6.23	5.79	5.44	5.04	4.71	4.44	4.21
3	ALLOW. SINGLE UNSUP. SPAN - m.	88.90	7.20	6.54	6.07	5.59	5.17	4.84	4.56	4.33
4	ALLOW. SINGLE UNSUP. SPAN - m.	101.60	7.54	6.85	6.28	5.73	5.31	4.96	4.68	4.44
5	ALLOW. SINGLE UNSUP. SPAN - m.	114.30	7.88	7.16	6.43	5.87	5.43	5.08	4.79	4.55
6	ALLOW. SINGLE UNSUP. SPAN - m.	127.00	8.22	7.36	6.58	6.01	5.56	5.20	4.90	4.65
7	ALLOW. SINGLE UNSUP. SPAN - m.	139.70	8.56	7.52	6.73	6.14	5.68	5.32	5.01	4.76
8	ALLOW. SINGLE UNSUP. SPAN - m.	152.40	8.87	7.68	6.87	6.27	5.80	5.43	5.12	4.86

Figures shown in blue to be multiplied by a factor of 0.9 - See Manual (Creep Stress)

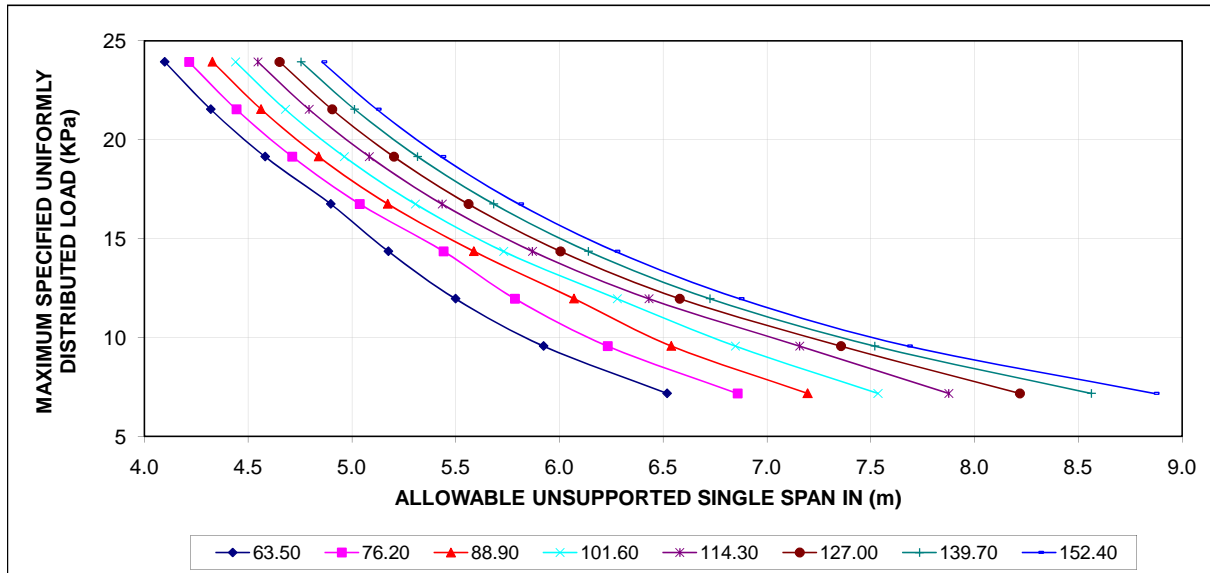



ULTRA-BOND COMPOSITE FLOOR DECK
 MAXIMUM SPECIFIED UNIFORMLY DISTRIBUTED LOAD (KPa)
 INCLUDES DEAD AND CONSTRUCTION LOAD CARRIED
 BY METAL DECK *(NOT SHOWN IN TABLES)*
 LIMIT STATE DESIGN (LSD) -METRIC UNITS

1.21 mm Deck
30 mm Rebar

INPUT SECTION:

ITEM	DESCRIPTION OR SECTION PROPERTIES	CONCRETE COVER ABOVE TOP OF METAL DECK (hf) OR (hc) (mm)							
		63.50	76.20	88.90	101.60	114.30	127.00	139.70	152.40
A	METAL DECK THICK (mm) (Td)	1.21	1.21	1.21	1.21	1.21	1.21	1.21	1.21
B	METAL DECK YIELD STRENGTH (KPa)(Fy)	280	280	280	280	280	280	280	280
C	METAL DECK EFF. (Ix) (mm ⁴)/m	6.95E+06	6.95E+06	6.95E+06	6.95E+06	6.95E+06	6.95E+06	6.95E+06	6.95E+06
D	METAL DECK EFF. (Sx) (mm ³)/m	6.18E+04	6.18E+04	6.18E+04	6.18E+04	6.18E+04	6.18E+04	6.18E+04	6.18E+04
E	METAL DECK (Es)(KPa)	2.03E+08	2.03E+08	2.03E+08	2.03E+08	2.03E+08	2.03E+08	2.03E+08	2.03E+08
F	# REINFORCING STEEL BAR DIA. (mm)	30	30	30	30	30	30	30	30
G	CONCRETE STRENGTH (f'c) (KPa)	3.00E+04	3.00E+04	3.00E+04	3.00E+04	3.00E+04	3.00E+04	3.00E+04	3.00E+04
H	CONCRETE (Ec) (KPa)	2.62E+07	2.62E+07	2.62E+07	2.62E+07	2.62E+07	2.62E+07	2.62E+07	2.62E+07
I	A _F (mm ²)/m	1830.917	1830.917	1830.917	1830.917	1830.917	1830.917	1830.917	1830.917
J	I _{x(f)} (mm ⁴)/m	9.80E+06	9.80E+06	9.80E+06	9.80E+06	9.80E+06	9.80E+06	9.80E+06	9.80E+06
K	ALLOWABLE FORCE (KN/m)	9.617	9.617	9.617	9.617	9.617	9.617	9.617	9.617
L	FINAL EFF. CROSS SECT. AREA A _{SO} (IN ²)	706	706	706	706	706	706	706	706
M	DEFLECTION CRITERIA K _{1,2,3,4}	1.333	1.333	1.333	1.333	1.333	1.333	1.333	1.333
N	DEFLECTION CRITERIA *	L/480	L/480	L/480	L/480	L/480	L/480	L/480	L/480

* DEFLECTION CRITERIA: L/360 (K₁=1), L/480 (K₂=1.333), L/600 (K₃=1.670) OR L/720 (K₄=2.0)
 # REINFORCING BAR Fy0=400MPa

OUTPUT SECTION #1

ITEM	DESCRIPTION	CONCRETE COVER ABOVE TOP OF METAL DECK (hf) OR (hc) (mm)							
		63.50	76.20	88.90	101.60	114.30	127.00	139.70	152.40
O	MAX. UNSHORED SPAN (C.L.1.006KPa).m.	4.28	3.95	3.67	3.43	3.21	3.02	2.86	2.71
P	MAX. UNSHORED SPAN (C.L.2.011KPa).m.	2.90	2.88	2.80	2.79	2.66	2.53	2.41	2.30
Q	TOTAL DEAD LOAD (NO CONST.)KPa.	2.586	2.885	3.184	3.484	3.783	4.082	4.381	4.680
R	CONCRETE VOLUME. m ³ /10m ²	1.000	1.127	1.254	1.381	1.508	1.635	1.762	1.889

C.L. = CONSTRUCTION LOAD (Pa)

OUTPUT SECTION #2: PLOT DATA - AND INPUT SECTION AS SHOWN #

ITEM	DESCRIPTION	(hf) OR (hc) (mm)	# MAXIMUM SPECIFIED UNIFORMLY DISTRIBUTED LOAD (KPa)							
			7.182	9.576	11.97	14.364	16.758	19.152	21.546	23.94
1	ALLOW. SINGLE UNSUP. SPAN - m.	63.50	6.58	5.98	5.55	5.23	4.96	4.75	4.57	4.41
2	ALLOW. SINGLE UNSUP. SPAN - m.	76.20	6.93	6.30	5.85	5.51	5.23	5.00	4.81	4.63
3	ALLOW. SINGLE UNSUP. SPAN - m.	88.90	7.29	6.62	6.15	5.79	5.50	5.26	5.02	4.76
4	ALLOW. SINGLE UNSUP. SPAN - m.	101.60	7.64	6.94	6.45	6.07	5.76	5.46	5.15	4.88
5	ALLOW. SINGLE UNSUP. SPAN - m.	114.30	7.99	7.26	6.74	6.35	5.98	5.59	5.27	5.00
6	ALLOW. SINGLE UNSUP. SPAN - m.	127.00	8.35	7.59	7.04	6.61	6.12	5.72	5.39	5.12
7	ALLOW. SINGLE UNSUP. SPAN - m.	139.70	8.71	7.91	7.34	6.75	6.25	5.85	5.51	5.23
8	ALLOW. SINGLE UNSUP. SPAN - m.	152.40	9.06	8.24	7.56	6.90	6.39	5.97	5.63	5.34

Figures shown in blue to be multiplied by a factor of 0.9 - See Manual (Creep Stress)

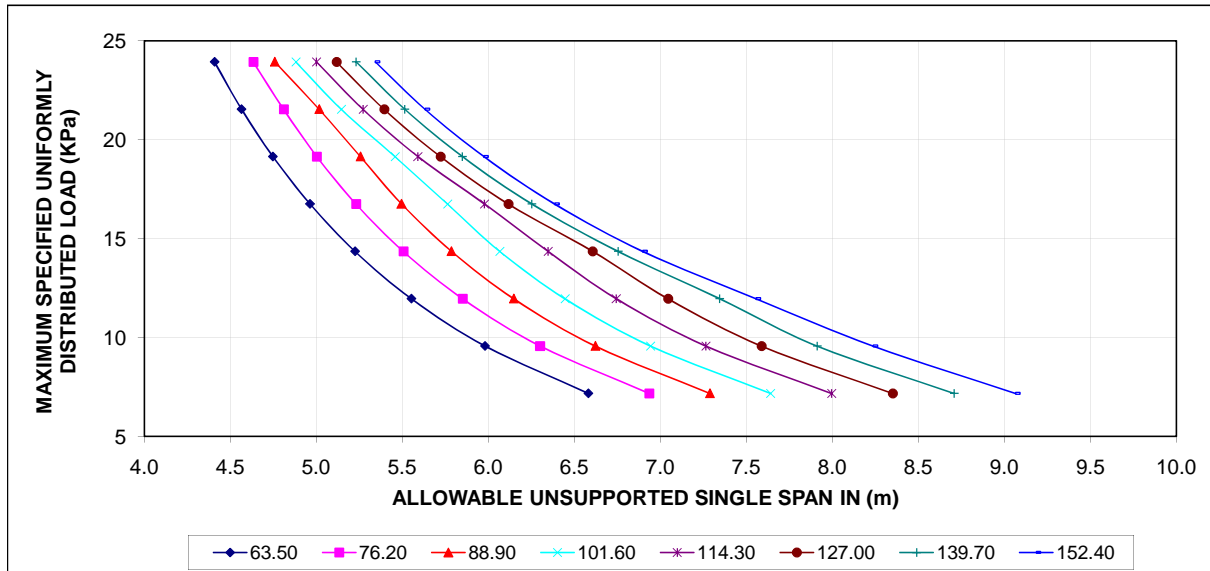



ULTRA-BOND COMPOSITE FLOOR DECK
 MAXIMUM SPECIFIED UNIFORMLY DISTRIBUTED LOAD (KPa)
 INCLUDES DEAD AND CONSTRUCTION LOAD CARRIED
 BY METAL DECK *(NOT SHOWN IN TABLES)*
 LIMIT STATE DESIGN (LSD) -METRIC UNITS

0.96mm Deck
10mm Rebar

INPUT SECTION:

ITEM	DESCRIPTION OR SECTION PROPERTIES	CONCRETE COVER ABOVE TOP OF METAL DECK (hf) OR (hc) (mm)							
		63.50	76.20	88.90	101.60	114.30	127.00	139.70	152.40
A	METAL DECK THICK (mm) (Td)	0.96	0.96	0.96	0.96	0.96	0.96	0.96	0.96
B	METAL DECK YIELD STRENGTH (KPa)(Fy)	280	280	280	280	280	280	280	280
C	METAL DECK EFF. (Ix) (mm ⁴)/m	4.60E+06	4.60E+06	4.60E+06	4.60E+06	4.60E+06	4.60E+06	4.60E+06	4.60E+06
D	METAL DECK EFF. (Sx) (mm ³)/m	3.68E+04	3.68E+04	3.68E+04	3.68E+04	3.68E+04	3.68E+04	3.68E+04	3.68E+04
E	METAL DECK (Es)(KPa)	2.03E+08	2.03E+08	2.03E+08	2.03E+08	2.03E+08	2.03E+08	2.03E+08	2.03E+08
F	# REINFORCING STEEL BAR DIA. (mm)	10	10	10	10	10	10	10	10
G	CONCRETE STRENGTH (f'c) (KPa)	3.00E+04	3.00E+04	3.00E+04	3.00E+04	3.00E+04	3.00E+04	3.00E+04	3.00E+04
H	CONCRETE (Ec) (KPa)	2.62E+07	2.62E+07	2.62E+07	2.62E+07	2.62E+07	2.62E+07	2.62E+07	2.62E+07
I	A _F (mm ²)/m	1454.150	1454.150	1454.150	1454.150	1454.150	1454.150	1454.150	1454.150
J	I _{x(F)} (mm ⁴)/m	7.78E+06	7.78E+06	7.78E+06	7.78E+06	7.78E+06	7.78E+06	7.78E+06	7.78E+06
K	ALLOWABLE FORCE (KN/m)	6.378	6.378	6.378	6.378	6.378	6.378	6.378	6.378
L	FINAL EFF. CROSS SECT. AREA A _{SO} (IN ²)	240	240	240	240	240	240	240	240
M	DEFLECTION CRITERIA K _{1,2,3,4}	1.000	1.000	1.000	1.000	1.000	1.000	1.000	1.000

* DEFLECTION CRITERIA: L/360 (K₁=1), L/480 (K₂=1.333), L/600 (K₃=1.670) OR L/720 (K₄=2.0)
 # REINFORCING BAR Fy0=400MPa

OUTPUT SECTION #1

ITEM	DESCRIPTION	CONCRETE COVER ABOVE TOP OF METAL DECK (hf) OR (hc) (mm)							
		63.50	76.20	88.90	101.60	114.30	127.00	139.70	152.40
O	MAX. UNSHORED SPAN (C.L.1.006KPa).m.	2.89	2.66	2.47	2.30	2.16	2.03	1.92	1.81
P	MAX. UNSHORED SPAN (C.L.2.011KPa).m.	2.25	2.11	1.99	1.88	1.78	1.69	1.61	1.54
Q	TOTAL DEAD LOAD (NO CONST.).KPa.	2.526	2.826	3.125	3.424	3.723	4.022	4.321	4.620
R	CONCRETE VOLUME. m ³ /10m ²	1.021	1.147	1.274	1.401	1.528	1.655	1.782	1.909

C.L. = CONSTRUCTION LOAD (Pa)

OUTPUT SECTION #2: PLOT DATA - AND INPUT SECTION AS SHOWN #

ITEM	DESCRIPTION	(hf) OR (hc) (mm)	# MAXIMUM SPECIFIED UNIFORMLY DISTRIBUTED LOAD (KPa)							
			7.182	9.576	11.97	14.364	16.758	19.152	21.546	23.94
1	ALLOW. SINGLE UNSUP. SPAN - m.	63.50	4.86	4.21	3.77	3.44	3.18	2.98	2.81	2.66
2	ALLOW. SINGLE UNSUP. SPAN - m.	76.20	5.00	4.33	3.87	3.53	3.27	3.06	2.88	2.74
3	ALLOW. SINGLE UNSUP. SPAN - m.	88.90	5.13	4.44	3.97	3.63	3.36	3.14	2.96	2.81
4	ALLOW. SINGLE UNSUP. SPAN - m.	101.60	5.26	4.55	4.07	3.72	3.44	3.22	3.04	2.88
5	ALLOW. SINGLE UNSUP. SPAN - m.	114.30	5.38	4.66	4.17	3.81	3.52	3.30	3.11	2.95
6	ALLOW. SINGLE UNSUP. SPAN - m.	127.00	5.51	4.77	4.26	3.89	3.60	3.37	3.18	3.02
7	ALLOW. SINGLE UNSUP. SPAN - m.	139.70	5.63	4.87	4.36	3.98	3.68	3.44	3.25	3.08
8	ALLOW. SINGLE UNSUP. SPAN - m.	152.40	5.74	4.97	4.45	4.06	3.76	3.52	3.32	3.15

FIGURES TO BE MULTIPLIED BY (0.9) - SHOWN IN YELLOW - SEE MANUAL (CREEP STRESS)

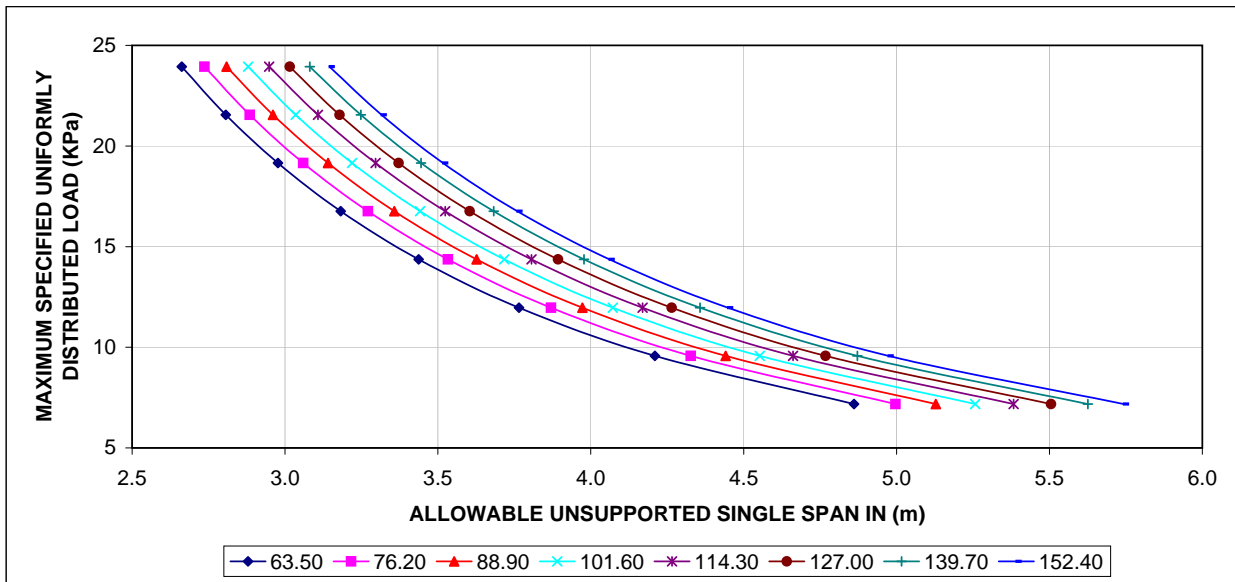



ULTRA-BOND COMPOSITE FLOOR DECK
 MAXIMUM SPECIFIED UNIFORMLY DISTRIBUTED LOAD (KPa)
 INCLUDES DEAD AND CONSTRUCTION LOAD CARRIED
 BY METAL DECK *(NOT SHOWN IN TABLES)*
 LIMIT STATE DESIGN (LSD) -METRIC UNITS

0.96mm Deck
15mm Rebar

INPUT SECTION:

ITEM	DESCRIPTION OR SECTION PROPERTIES	CONCRETE COVER ABOVE TOP OF METAL DECK (hf) OR (hc) (mm)							
		63.50	76.20	88.90	101.60	114.30	127.00	139.70	152.40
A	METAL DECK THICK (mm) (Td)	0.96	0.96	0.96	0.96	0.96	0.96	0.96	0.96
B	METAL DECK YIELD STRENGTH (KPa)(Fy)	280	280	280	280	280	280	280	280
C	METAL DECK EFF. (Ix) (mm ⁴ /m)	4.60E+06	4.60E+06	4.60E+06	4.60E+06	4.60E+06	4.60E+06	4.60E+06	4.60E+06
D	METAL DECK EFF. (Sx) (mm ³ /m)	3.68E+04	3.68E+04	3.68E+04	3.68E+04	3.68E+04	3.68E+04	3.68E+04	3.68E+04
E	METAL DECK (Es)(KPa)	2.03E+08	2.03E+08	2.03E+08	2.03E+08	2.03E+08	2.03E+08	2.03E+08	2.03E+08
F	# REINFORCING STEEL BAR DIA. (mm)	15	15	15	15	15	15	15	15
G	CONCRETE STRENGTH (f'c) (KPa)	3.00E+04	3.00E+04	3.00E+04	3.00E+04	3.00E+04	3.00E+04	3.00E+04	3.00E+04
H	CONCRETE (Ec) (KPa)	2.62E+07	2.62E+07	2.62E+07	2.62E+07	2.62E+07	2.62E+07	2.62E+07	2.62E+07
I	A _F (mm ² /m)	1454.150	1454.150	1454.150	1454.150	1454.150	1454.150	1454.150	1454.150
J	I _{x(F)} (mm ⁴ /m)	7.78E+06	7.78E+06	7.78E+06	7.78E+06	7.78E+06	7.78E+06	7.78E+06	7.78E+06
K	ALLOWABLE FORCE (KN/m)	6.378	6.378	6.378	6.378	6.378	6.378	6.378	6.378
L	FINAL EFF. CROSS SECT. AREA A _{SO} (IN ²)	323	323	323	323	323	323	323	323
M	DEFLECTION CRITERIA K _{1,2,3,4}	1.000	1.000	1.000	1.000	1.000	1.000	1.000	1.000

* DEFLECTION CRITERIA: L/360 (K₁=1), L/480 (K₂=1.333), L/600 (K₃=1.670) OR L/720 (K₄=2.0)
 # REINFORCING BAR Fy0=400MPa

OUTPUT SECTION #1

ITEM	DESCRIPTION	CONCRETE COVER ABOVE TOP OF METAL DECK (hf) OR (hc) (mm)							
		63.50	76.20	88.90	101.60	114.30	127.00	139.70	152.40
O	MAX. UNSHORED SPAN (C.L.1.006KPa).m.	2.89	2.66	2.47	2.30	2.16	2.03	1.91	1.81
P	MAX. UNSHORED SPAN (C.L.2.011KPa).m.	2.25	2.11	1.99	1.88	1.78	1.69	1.61	1.54
Q	TOTAL DEAD LOAD (NO CONST.).KPa.	2.531	2.830	3.129	3.429	3.728	4.027	4.326	4.625
R	CONCRETE VOLUME. m ³ /10m ²	1.017	1.144	1.271	1.398	1.525	1.652	1.779	1.906

C.L. = CONSTRUCTION LOAD (Pa)

OUTPUT SECTION #2: PLOT DATA - AND INPUT SECTION AS SHOWN #

ITEM	DESCRIPTION	(hf) OR (hc) (mm)	# MAXIMUM SPECIFIED UNIFORMLY DISTRIBUTED LOAD (KPa)							
			7.182	9.576	11.97	14.364	16.758	19.152	21.546	23.94
1	ALLOW. SINGLE UNSUP. SPAN - m.	63.50	5.62	4.87	4.35	3.98	3.68	3.44	3.25	3.08
2	ALLOW. SINGLE UNSUP. SPAN - m.	76.20	5.78	5.01	4.48	4.09	3.78	3.54	3.34	3.17
3	ALLOW. SINGLE UNSUP. SPAN - m.	88.90	5.93	5.14	4.60	4.20	3.88	3.63	3.43	3.25
4	ALLOW. SINGLE UNSUP. SPAN - m.	101.60	6.08	5.27	4.71	4.30	3.98	3.72	3.51	3.33
5	ALLOW. SINGLE UNSUP. SPAN - m.	114.30	6.23	5.39	4.82	4.40	4.08	3.81	3.60	3.41
6	ALLOW. SINGLE UNSUP. SPAN - m.	127.00	6.37	5.52	4.93	4.50	4.17	3.90	3.68	3.49
7	ALLOW. SINGLE UNSUP. SPAN - m.	139.70	6.51	5.64	5.04	4.60	4.26	3.99	3.76	3.57
8	ALLOW. SINGLE UNSUP. SPAN - m.	152.40	6.65	5.76	5.15	4.70	4.35	4.07	3.84	3.64

FIGURES TO BE MULTIPLIED BY (0.9) - SHOWN IN YELLOW - SEE MANUAL (CREEP STRESS)

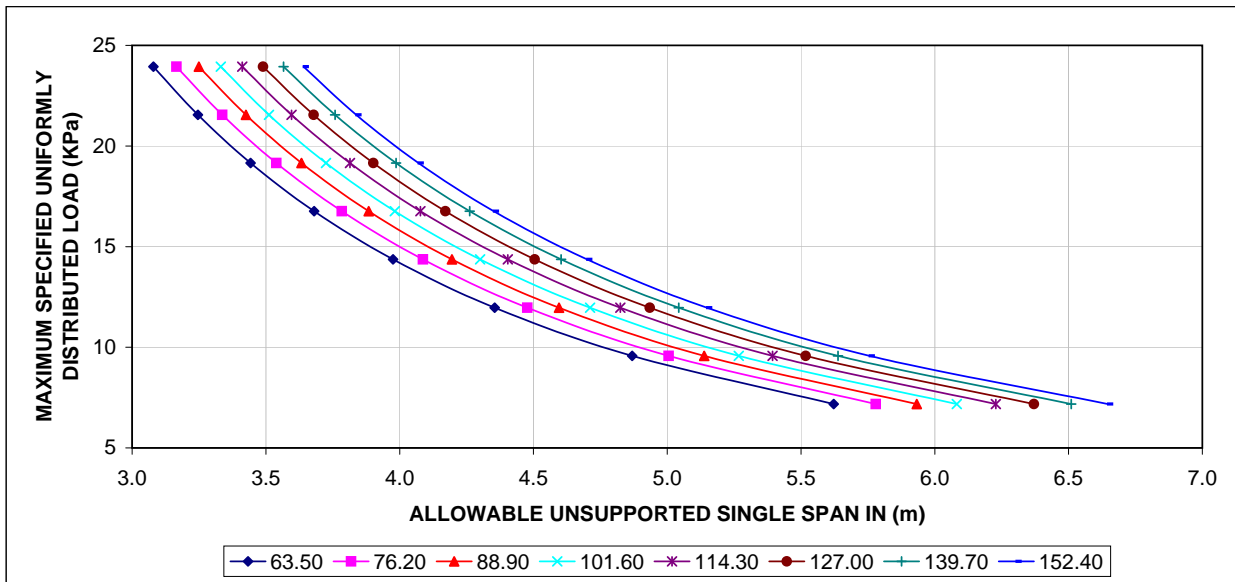



ULTRA-BOND COMPOSITE FLOOR DECK
 MAXIMUM SPECIFIED UNIFORMLY DISTRIBUTED LOAD (KPa)
 INCLUDES DEAD AND CONSTRUCTION LOAD CARRIED
 BY METAL DECK *(NOT SHOWN IN TABLES)*
 LIMIT STATE DESIGN (LSD) -METRIC UNITS

0.96mm Deck
20mm Rebar

INPUT SECTION:

ITEM	DESCRIPTION OR SECTION PROPERTIES	CONCRETE COVER ABOVE TOP OF METAL DECK (hf) OR (hc) (mm)							
		63.50	76.20	88.90	101.60	114.30	127.00	139.70	152.40
A	METAL DECK THICK (mm) (Td)	0.96	0.96	0.96	0.96	0.96	0.96	0.96	0.96
B	METAL DECK YIELD STRENGTH (KPa)(Fy)	280	280	280	280	280	280	280	280
C	METAL DECK EFF. (Ix) (mm ⁴ /m)	4.60E+06	4.60E+06	4.60E+06	4.60E+06	4.60E+06	4.60E+06	4.60E+06	4.60E+06
D	METAL DECK EFF. (Sx) (mm ³ /m)	3.68E+04	3.68E+04	3.68E+04	3.68E+04	3.68E+04	3.68E+04	3.68E+04	3.68E+04
E	METAL DECK (Es)(KPa)	2.03E+08	2.03E+08	2.03E+08	2.03E+08	2.03E+08	2.03E+08	2.03E+08	2.03E+08
F	# REINFORCING STEEL BAR DIA. (mm)	20	20	20	20	20	20	20	20
G	CONCRETE STRENGTH (f'c) (KPa)	3.00E+04	3.00E+04	3.00E+04	3.00E+04	3.00E+04	3.00E+04	3.00E+04	3.00E+04
H	CONCRETE (Ec) (KPa)	2.62E+07	2.62E+07	2.62E+07	2.62E+07	2.62E+07	2.62E+07	2.62E+07	2.62E+07
I	A _F (mm ² /m)	1454.150	1454.150	1454.150	1454.150	1454.150	1454.150	1454.150	1454.150
J	I _{x(F)} (mm ⁴ /m)	7.78E+06	7.78E+06	7.78E+06	7.78E+06	7.78E+06	7.78E+06	7.78E+06	7.78E+06
K	ALLOWABLE FORCE (KN/m)	6.378	6.378	6.378	6.378	6.378	6.378	6.378	6.378
L	FINAL EFF. CROSS SECT. AREA A _{SO} (IN ²)	361	361	361	361	361	361	361	361
M	DEFLECTION CRITERIA K _{1,2,3,4}	1.000	1.000	1.000	1.000	1.000	1.000	1.000	1.000

* DEFLECTION CRITERIA: L/360 (K₁=1), L/480 (K₂=1.333), L/600 (K₃=1.670) OR L/720 (K₄=2.0)
 # REINFORCING BAR Fy0=400MPa

OUTPUT SECTION #1

ITEM	DESCRIPTION	CONCRETE COVER ABOVE TOP OF METAL DECK (hf) OR (hc) (mm)							
		63.50	76.20	88.90	101.60	114.30	127.00	139.70	152.40
O	MAX. UNSHORED SPAN (C.L.1.006KPa).m.	2.88	2.66	2.46	2.30	2.15	2.02	1.91	1.81
P	MAX. UNSHORED SPAN (C.L.2.011KPa).m.	2.24	2.10	1.98	1.87	1.78	1.69	1.61	1.54
Q	TOTAL DEAD LOAD (NO CONST.).KPa.	2.538	2.837	3.136	3.435	3.734	4.034	4.333	4.632
R	CONCRETE VOLUME. m ³ /10m ²	1.013	1.140	1.267	1.394	1.521	1.648	1.775	1.901

C.L. = CONSTRUCTION LOAD (Pa)

OUTPUT SECTION #2: PLOT DATA - AND INPUT SECTION AS SHOWN #

ITEM	DESCRIPTION	(hf) OR (hc) (mm)	# MAXIMUM SPECIFIED UNIFORMLY DISTRIBUTED LOAD (KPa)								
			7.182	9.576	11.97	14.364	16.758	19.152	21.546	23.94	
1	ALLOW. SINGLE UNSUP. SPAN - m.	63.50	5.94	5.15	4.60	4.20	3.89	3.64	3.43	3.26	
2	ALLOW. SINGLE UNSUP. SPAN - m.	76.20	6.11	5.29	4.73	4.32	4.00	3.74	3.53	3.35	
3	ALLOW. SINGLE UNSUP. SPAN - m.	88.90	6.27	5.43	4.86	4.44	4.11	3.84	3.62	3.44	
4	ALLOW. SINGLE UNSUP. SPAN - m.	101.60	6.43	5.57	4.98	4.55	4.21	3.94	3.71	3.52	
5	ALLOW. SINGLE UNSUP. SPAN - m.	114.30	6.59	5.70	5.10	4.66	4.31	4.03	3.80	3.61	
6	ALLOW. SINGLE UNSUP. SPAN - m.	127.00	6.74	5.83	5.22	4.76	4.41	4.13	3.89	3.69	
7	ALLOW. SINGLE UNSUP. SPAN - m.	139.70	6.88	5.96	5.33	4.87	4.51	4.22	3.97	3.77	
8	ALLOW. SINGLE UNSUP. SPAN - m.	152.40	7.03	6.09	5.44	4.97	4.60	4.30	4.06	3.85	

FIGURES TO BE MULTIPLIED BY (0.9) - SHOWN IN YELLOW - SEE MANUAL (CREEP STRESS)

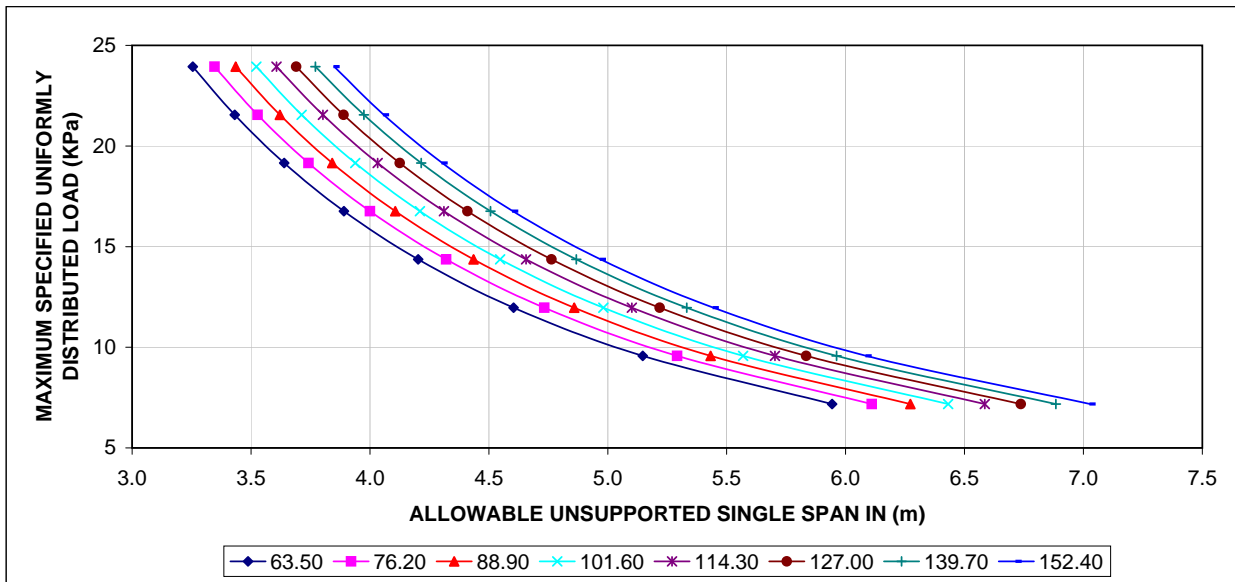



ULTRA-BOND COMPOSITE FLOOR DECK
 MAXIMUM SPECIFIED UNIFORMLY DISTRIBUTED LOAD (KPa)
 INCLUDES DEAD AND CONSTRUCTION LOAD CARRIED
 BY METAL DECK *(NOT SHOWN IN TABLES)*
 LIMIT STATE DESIGN (LSD) -METRIC UNITS

0.96mm Deck
25mm Rebar

INPUT SECTION:

ITEM	DESCRIPTION OR SECTION PROPERTIES	CONCRETE COVER ABOVE TOP OF METAL DECK (hf) OR (hc) (mm)							
		63.50	76.20	88.90	101.60	114.30	127.00	139.70	152.40
A	METAL DECK THICK (mm) (Td)	0.96	0.96	0.96	0.96	0.96	0.96	0.96	0.96
B	METAL DECK YIELD STRENGTH (KPa)(Fy)	280	280	280	280	280	280	280	280
C	METAL DECK EFF. (Ix) (mm ⁴ /m)	4.60E+06	4.60E+06	4.60E+06	4.60E+06	4.60E+06	4.60E+06	4.60E+06	4.60E+06
D	METAL DECK EFF. (Sx) (mm ³ /m)	3.68E+04	3.68E+04	3.68E+04	3.68E+04	3.68E+04	3.68E+04	3.68E+04	3.68E+04
E	METAL DECK (Es)(KPa)	2.03E+08	2.03E+08	2.03E+08	2.03E+08	2.03E+08	2.03E+08	2.03E+08	2.03E+08
F	# REINFORCING STEEL BAR DIA. (mm)	25	25	25	25	25	25	25	25
G	CONCRETE STRENGTH (f'c) (KPa)	3.00E+04	3.00E+04	3.00E+04	3.00E+04	3.00E+04	3.00E+04	3.00E+04	3.00E+04
H	CONCRETE (Ec) (KPa)	2.62E+07	2.62E+07	2.62E+07	2.62E+07	2.62E+07	2.62E+07	2.62E+07	2.62E+07
I	A _F (mm ² /m)	1454.150	1454.150	1454.150	1454.150	1454.150	1454.150	1454.150	1454.150
J	I _{x(F)} (mm ⁴ /m)	7.78E+06	7.78E+06	7.78E+06	7.78E+06	7.78E+06	7.78E+06	7.78E+06	7.78E+06
K	ALLOWABLE FORCE (KN/m)	6.378	6.378	6.378	6.378	6.378	6.378	6.378	6.378
L	FINAL EFF. CROSS SECT. AREA A _{SO} (IN ²)	490	490	490	490	490	490	490	490
M	DEFLECTION CRITERIA K _{1,2,3,4}	1.000	1.000	1.000	1.000	1.000	1.000	1.000	1.000

* DEFLECTION CRITERIA: L/360 (K₁=1), L/480 (K₂=1.333), L/600 (K₃=1.670) OR L/720 (K₄=2.0)
 # REINFORCING BAR Fy0=400MPa

OUTPUT SECTION #1

ITEM	DESCRIPTION	CONCRETE COVER ABOVE TOP OF METAL DECK (hf) OR (hc) (mm)							
		63.50	76.20	88.90	101.60	114.30	127.00	139.70	152.40
O	MAX. UNSHORED SPAN (C.L.1.006KPa).m.	2.87	2.65	2.46	2.29	2.15	2.02	1.91	1.81
P	MAX. UNSHORED SPAN (C.L.2.011KPa).m.	2.24	2.10	1.98	1.87	1.77	1.69	1.61	1.53
Q	TOTAL DEAD LOAD (NO CONST.).KPa.	2.547	2.846	3.145	3.444	3.743	4.042	4.341	4.641
R	CONCRETE VOLUME. m ³ /10m ²	1.007	1.134	1.261	1.388	1.515	1.642	1.769	1.896

C.L. = CONSTRUCTION LOAD (Pa)

OUTPUT SECTION #2: PLOT DATA - AND INPUT SECTION AS SHOWN #

ITEM	DESCRIPTION	(hf) OR (hc) (mm)	# MAXIMUM SPECIFIED UNIFORMLY DISTRIBUTED LOAD (KPa)							
			7.182	9.576	11.97	14.364	16.758	19.152	21.546	23.94
1	ALLOW. SINGLE UNSUP. SPAN - m.	63.50	6.90	5.97	5.34	4.88	4.52	4.22	3.98	3.78
2	ALLOW. SINGLE UNSUP. SPAN - m.	76.20	7.09	6.14	5.49	5.02	4.64	4.34	4.10	3.88
3	ALLOW. SINGLE UNSUP. SPAN - m.	88.90	7.28	6.31	5.64	5.15	4.77	4.46	4.20	3.99
4	ALLOW. SINGLE UNSUP. SPAN - m.	101.60	7.47	6.47	5.78	5.28	4.89	4.57	4.31	4.09
5	ALLOW. SINGLE UNSUP. SPAN - m.	114.30	7.65	6.62	5.92	5.41	5.01	4.68	4.42	4.19
6	ALLOW. SINGLE UNSUP. SPAN - m.	127.00	7.82	6.78	6.06	5.53	5.12	4.79	4.52	4.29
7	ALLOW. SINGLE UNSUP. SPAN - m.	139.70	8.00	6.93	6.19	5.66	5.24	4.90	4.62	4.38
8	ALLOW. SINGLE UNSUP. SPAN - m.	152.40	8.17	7.07	6.33	5.77	5.35	5.00	4.71	4.47

FIGURES TO BE MULTIPLIED BY (0.9) - SHOWN IN YELLOW - SEE MANUAL (CREEP STRESS)

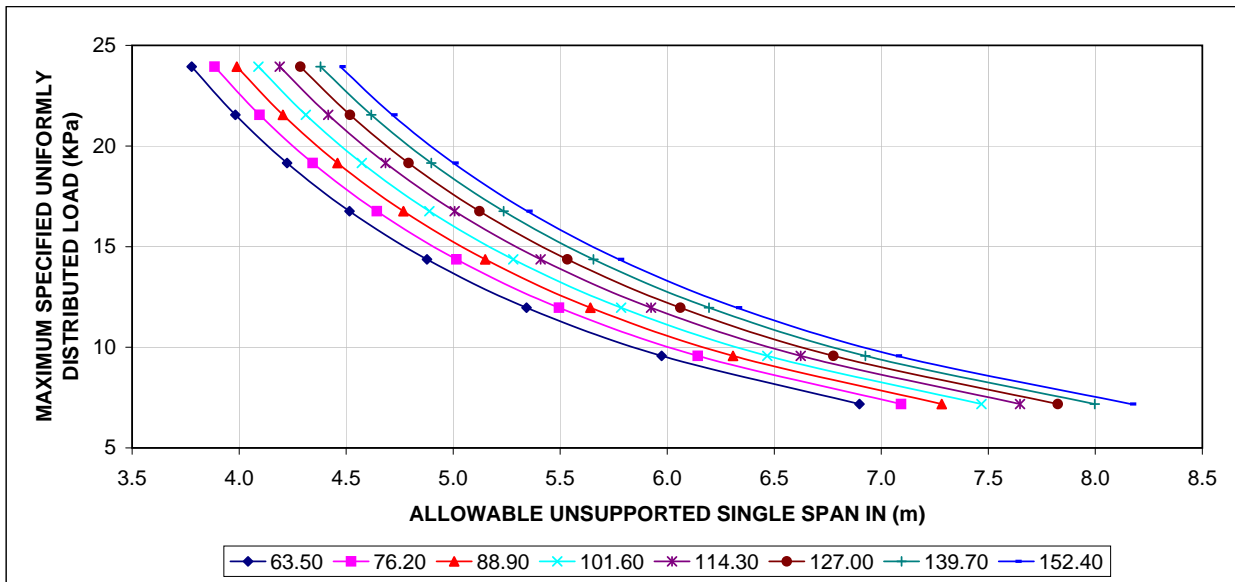



ULTRA-BOND COMPOSITE FLOOR DECK
 MAXIMUM SPECIFIED UNIFORMLY DISTRIBUTED LOAD (KPa)
 INCLUDES DEAD AND CONSTRUCTION LOAD CARRIED
 BY METAL DECK *(NOT SHOWN IN TABLES)*
 LIMIT STATE DESIGN (LSD) -METRIC UNITS

0.96mm Deck
30mm Rebar

INPUT SECTION:

ITEM	DESCRIPTION OR SECTION PROPERTIES	CONCRETE COVER ABOVE TOP OF METAL DECK (hf) OR (hc) (mm)							
		63.50	76.20	88.90	101.60	114.30	127.00	139.70	152.40
A	METAL DECK THICK (mm) (Td)	0.96	0.96	0.96	0.96	0.96	0.96	0.96	0.96
B	METAL DECK YIELD STRENGTH (KPa)(Fy)	280	280	280	280	280	280	280	280
C	METAL DECK EFF. (Ix) (mm ⁴)/m	4.60E+06	4.60E+06	4.60E+06	4.60E+06	4.60E+06	4.60E+06	4.60E+06	4.60E+06
D	METAL DECK EFF. (Sx) (mm ³)/m	3.68E+04	3.68E+04	3.68E+04	3.68E+04	3.68E+04	3.68E+04	3.68E+04	3.68E+04
E	METAL DECK (Es)(KPa)	2.03E+08	2.03E+08	2.03E+08	2.03E+08	2.03E+08	2.03E+08	2.03E+08	2.03E+08
F	# REINFORCING STEEL BAR DIA. (mm)	30	30	30	30	30	30	30	30
G	CONCRETE STRENGTH (f'c) (KPa)	3.00E+04	3.00E+04	3.00E+04	3.00E+04	3.00E+04	3.00E+04	3.00E+04	3.00E+04
H	CONCRETE (Ec) (KPa)	2.62E+07	2.62E+07	2.62E+07	2.62E+07	2.62E+07	2.62E+07	2.62E+07	2.62E+07
I	A _F (mm ²)/m	1454.150	1454.150	1454.150	1454.150	1454.150	1454.150	1454.150	1454.150
J	I _{x(F)} (mm ⁴)/m	7.78E+06	7.78E+06	7.78E+06	7.78E+06	7.78E+06	7.78E+06	7.78E+06	7.78E+06
K	ALLOWABLE FORCE (KN/m)	6.378	6.378	6.378	6.378	6.378	6.378	6.378	6.378
L	FINAL EFF. CROSS SECT. AREA A _{SO} (IN ²)	706	706	706	706	706	706	706	706
M	DEFLECTION CRITERIA K _{1,2,3,4}	1.000	1.000	1.000	1.000	1.000	1.000	1.000	1.000

* DEFLECTION CRITERIA: L/360 (K₁=1), L/480 (K₂=1.333), L/600 (K₃=1.670) OR L/720 (K₄=2.0)
 # REINFORCING BAR Fy0=400MPa

OUTPUT SECTION #1

ITEM	DESCRIPTION	CONCRETE COVER ABOVE TOP OF METAL DECK (hf) OR (hc) (mm)							
		63.50	76.20	88.90	101.60	114.30	127.00	139.70	152.40
O	MAX. UNSHORED SPAN (C.L.1.006KPa).m.	2.86	2.64	2.45	2.29	2.14	2.02	1.90	1.80
P	MAX. UNSHORED SPAN (C.L.2.011KPa).m.	2.23	2.10	1.98	1.87	1.77	1.68	1.60	1.53
Q	TOTAL DEAD LOAD (NO CONST.).KPa.	2.557	2.856	3.155	3.455	3.754	4.053	4.352	4.651
R	CONCRETE VOLUME. m ³ /10m ²	1.000	1.127	1.254	1.381	1.508	1.635	1.762	1.889

C.L. = CONSTRUCTION LOAD (Pa)

OUTPUT SECTION #2: PLOT DATA - AND INPUT SECTION AS SHOWN #

ITEM	DESCRIPTION	(hf) OR (hc) (mm)	# MAXIMUM SPECIFIED UNIFORMLY DISTRIBUTED LOAD (KPa)							
			7.182	9.576	11.97	14.364	16.758	19.152	21.546	23.94
			1	ALLOW. SINGLE UNSUP. SPAN - m.	63.50	7.13	6.48	6.01	5.66	5.38
2	ALLOW. SINGLE UNSUP. SPAN - m.	76.20	7.52	6.83	6.34	5.97	5.54	5.18	4.89	4.64
3	ALLOW. SINGLE UNSUP. SPAN - m.	88.90	7.90	7.18	6.67	6.15	5.69	5.32	5.02	4.76
4	ALLOW. SINGLE UNSUP. SPAN - m.	101.60	8.29	7.53	6.91	6.30	5.84	5.46	5.15	4.88
5	ALLOW. SINGLE UNSUP. SPAN - m.	114.30	8.68	7.88	7.07	6.46	5.98	5.59	5.27	5.00
6	ALLOW. SINGLE UNSUP. SPAN - m.	127.00	9.07	8.09	7.24	6.61	6.12	5.72	5.40	5.12
7	ALLOW. SINGLE UNSUP. SPAN - m.	139.70	9.45	8.27	7.40	6.76	6.26	5.85	5.52	5.23
8	ALLOW. SINGLE UNSUP. SPAN - m.	152.40	9.76	8.45	7.56	6.90	6.39	5.98	5.63	5.34

FIGURES TO BE MULTIPLIED BY (0.9) - SHOWN IN YELLOW - SEE MANUAL (CREEP STRESS)

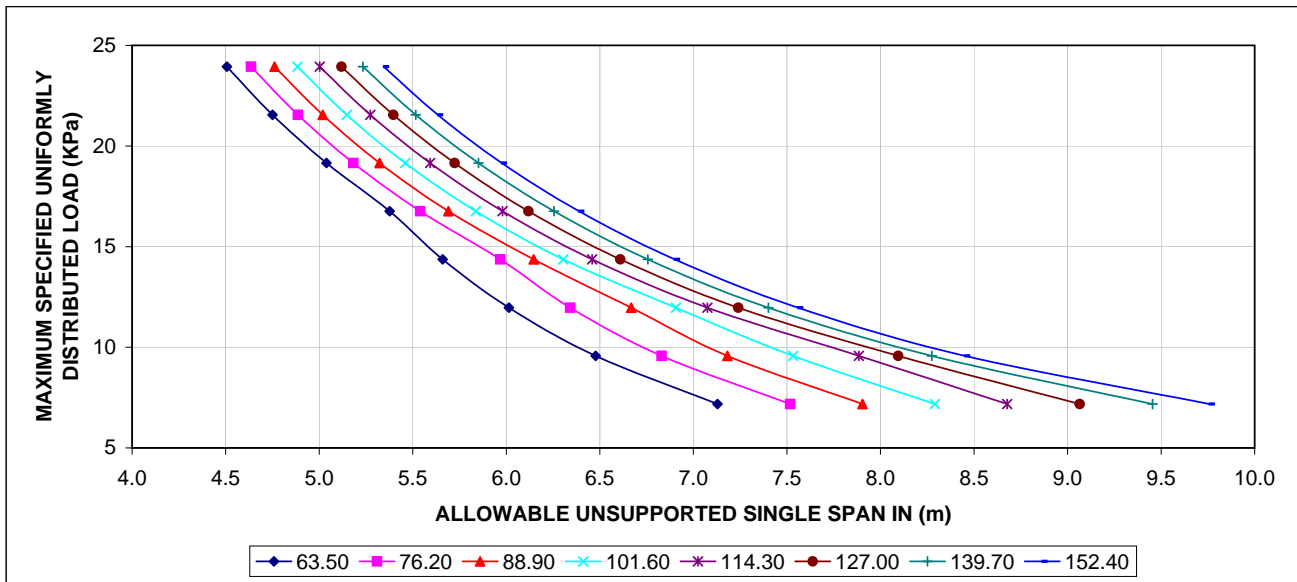



4101 – 69 AVE
Edmonton, Alberta T6B-2V2
Phone: (780) 440-4499
Toll Free: 1-866-440-4499
Fax: (780) 465-4910

Steelform Building Systems Inc
60 Enterprise Road
Toronto, Ontario M9W-1C9
Phone: (416) 245-7006
Toll Free: 1-877-245-7073
Fax: (416) 245-7698

Book Design and Illustration by Shane Lynch and TheCGN Designs
www.thecgn.com

DESIGN TABLE DETAILS	- 1 -
INTRODUCTION	- 2 -
COMPOSITE ACTION	- 2 -
DESIGN RESPONSIBILITY	- 2 -
DESIGN CRITERIA AND TECHNICAL DATA	- 3 -
STEEL DECK MATERIAL	- 3 -
LIMIT STATE DESIGN (LSD).....	- 3 -
STEEL DECK SECTION PROPERTIES	- 4 -
DESCRIPTION OF LOAD TABLES.....	- 4 -
CONSTRUCTION LOADS	- 13 -
COMPOSITE LOADING	- 13 -
COMPUTER PROGRAM	- 14 -
EXAMPLES FOR THE PROPER USE OF STEELFORM ULTRA-BOND LOAD TABLES.....	- 14 -
LINK	- 21 -
CONSTRUCTION GUIDELINES	- 21 -
DECKING INSTALLATION	- 21 -
<i>Restraint Straps</i>	- 21 -
<i>Penetrations</i>	- 21 -
<i>Temporary Supports</i>	- 22 -
<i>Hanger System</i>	- 22 -
<i>End Closures</i>	- 22 -
<i>Side-lap Washers</i>	- 23 -
<i>Cantilevers</i>	- 23 -
<i>Perimeter Edge Trims</i>	- 23 -
<i>Columns and Ultra-Bond Floor Decking</i>	- 23 -
<i>Rib Reinforcement and Mesh Placement</i>	- 23 -
<i>Concrete Placement</i>	- 23 -
<i>Service Holes</i>	- 23 -
<i>Ceiling Hanger System</i>	- 24 -
TRIMS AND ACCESSORIES	- 24 -

Design Table Details

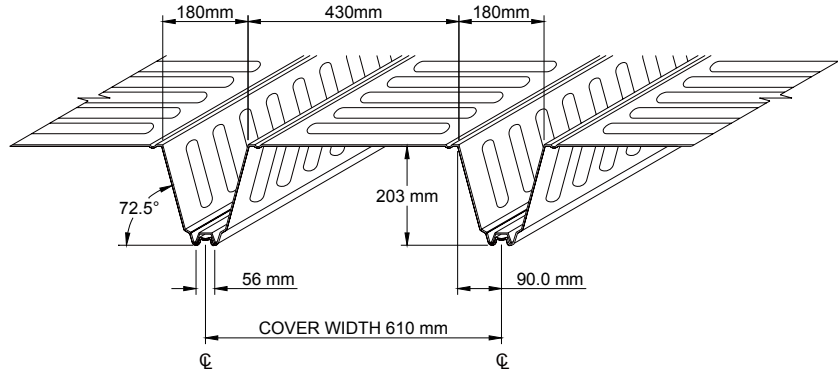

		ULTRABOND STEEL DECK FULL SECTION PROPERTIES (Imperial Units)				
NOMINAL THICKNESS (IN)	CORE THICKNESS (IN) ¹	PROFILE DEPTH (IN)	PROFILE WEIGHT (PSF)	A _F (IN ²)/ft	I _{x(F)} (IN ⁴)/ft	S _{x(F)} (IN ³)/ft
0.0394	0.0378	8.0" (out to out)	2.34	0.687	5.70	1.02
0.0492	0.0476	8.0" (out to out)	2.94	0.865	7.18	1.287

NOTES 1 Design Thickness

		ULTRABOND STEEL DECK EFFECTIVE SECTION PROPERTIES (Si-Metric Units)				
NOMINAL THICKNESS (mm)	CORE THICKNESS (mm) ¹	PROFILE DEPTH (mm)	PROFILE WEIGHT (kPa)	A _e (mm ² /m)	I _{e(x)} (10 ⁶ mm ⁴ /m)	S _{e(x)} (10 ³ mm ³ /m)
1.00	0.96	203.2	0.112	617	4.60	36.70
1.25	1.21	203.2	0.141	861	6.93	61.36

NOTES 1 Design Thickness

		ULTRABOND STEEL DECK EFFECTIVE SECTION PROPERTIES (Imperial Units)				
NOMINAL THICKNESS (IN)	CORE THICKNESS (IN) ¹	PROFILE DEPTH (IN)	PROFILE WEIGHT (PSF)	A _e (IN ²)/ft	I _{e(x)} (IN ⁴)/ft	S _{e(x)} (IN ³)/ft
0.0394	0.0378	8.00	2.34	0.291	3.37	0.684
0.0492	0.0476	8.00	2.94	0.406	5.09	1.15

NOTES 1 Design Thickness

INTRODUCTION

This Manual and the Load Tables present data to structural engineers, and design professionals on the design of the Steelform Ultra-Bond Composite Floor Deck System, incorporating steel reinforcing tension bars. This System uses specially formed steel deck profiles consisting of extensive lugs embossed in the metal deck to allow for positive shear bond between steel and concrete. The aim of this System is to provide:

- a low cost method to obtain a working surface for various trades
- formwork for the concrete floor slab
- positive bending reinforcement for the cured concrete.

Ultra-Bond Composite Floor Deck System can be used in conjunction with composite beam design and provides many varying fire-rating assemblies listed by UL and ULC. **The metal deck can often be modified by addition of flat plates to the underside, to form electrical wire conduits or cold/warm air ducts.**

Composite Action

Composite action (steel and concrete) is developed when two load-carrying structural members, such as concrete and steel, are integrally connected and deflect as a single unit under any load.

The basic advantages resulting from composite design are:

- Reduction in weight of steel (approx. 30%),
- Shallower structural supports,
- Increase in floor stiffness, improved deflection performance,
- Increase in overload capacity (safety due to overload).

Design Responsibility

This Manual and Load Tables are prepared as a guide for structural engineers and design professionals. Every precaution has been taken to ensure that all information presented is factual and that numerical values are accurate. Steelform Building Products Inc. assumes no responsibility for any design liability or errors resulting from the use of this information and Load Tables.

DESIGN CRITERIA AND TECHNICAL DATA

Steel Deck Material

The steel deck used is a continuously hot-dipped zinc coated structural quality sheet, delivered for fabrication in coils. It conforms to ASTM A653M, Grade 280 with a yield strength of 280 MPa (40.6 ksi).

The sheet is available in several coatings for corrosion protection. These coatings would meet the applicable requirements of ASTM A924M. In most applications, the deck is in an interior environment where the atmosphere is mild with regard to corrosion. A ZF75 finish is suitable for this. If the likelihood of corrosion is significantly higher, a heavier galvanizing finish such as Z275 may be appropriate.

- Reinforcing Steel Bars are provided in various diameters, as shown in Load Tables, from 10 mm dia. to 30 mm dia. and meet the requirements of CAN/CSA G30.18 – M1992, with minimum yield strength of 400 MPa (58 ksi). The clear distance of each bar from the base of the metal deck is 39 mm (1.54 in.).
- Concrete is assumed to have a minimum strength of 30 MPa (4.35 ksi) after 28 days curing with maximum size aggregate of 20 mm (0.79 in.) and normal density of 2400 kg/m³ (150 pcf).

Limit State Design (LSD)

Limit State Design principles were used in the development of the Load Tables in accordance with the National Building Code of Canada 1995. Since the self-weight of the steel deck and the concrete have been already included in the structural Load Tables, the Maximum Specified Load shall be:

$$L_s = LL + (0.833) (DL)$$

L_s = Maximum Specified Load

LL = Specified Live Load

DL = Specified Superimposed Dead Load

$$0.8333 = 1.25/1.50$$

1.25 = Dead Load Factor

1.50 = Live Load Factor

For deflection control (serviceability) the Maximum Specified Load is:

$$L_s = LL + (0.833) (DL)$$

L_s = Maximum Specified Load

LL = Specified Live Load

DL = Specified Superimposed Dead Load.

Steel Deck Section Properties

Steel Deck Section Properties have been evaluated based on AISI/COS/NASPEC 2001, approved in Canada by CSA 136-01, and approved in Mexico by CANACERO.

Load Tables

Both, strength and deflection criteria were considered.

- **Strength – only flexure criteria was considered in the calculations, as shear bond (based on testing) is not a mode of failure. Shear bond is defined as the bond between concrete and metal deck, it can be chemical or mechanical (with lugs).**
- Deflection calculations are based on deflection limit of L/360; however, changing the (k) Factor in the Input Section of the Load Tables can accommodate other criteria, such as L/480, L/600 or L/720.

Modular Ratio (n):

$$n = E_s / E_c$$

E_s = Steel Modulus of Elasticity

E_c = Concrete Modulus of Elasticity

Description of Load Tables

The Load Tables contain three Tables and one Multi Graph Chart at the bottom of the page:

- The first Table's **Input Section** contains all the required input information to generate the output data.
- The second Table's **Output Section #1** shows the allowable unshored spans, total dead load and concrete volume.
- (h_f) or (h_c) indicate the maximum height of the concrete cover above top of the metal deck.
- The third Table's **Output Section #2 - Plot Data and Input Section As Shown #**, indicates allowable single unsupported span based on concrete cover above metal deck (h_f) or (h_c) and maximum specified uniformly distributed load.
- The bottom Graphs allow the designer to determine Allowable Unsupported Single Span or Maximum Specified Uniformly Distributed Load for conditions outside those shown in Output Section # 2, for various concrete covers above metal deck top (h_f) or (h_c).

Ultrabond Workbook, Sheets 1 to 10, are in Imperial Units while Ultrabond Workbook, Sheets 11 to 20, are in Metric Units.

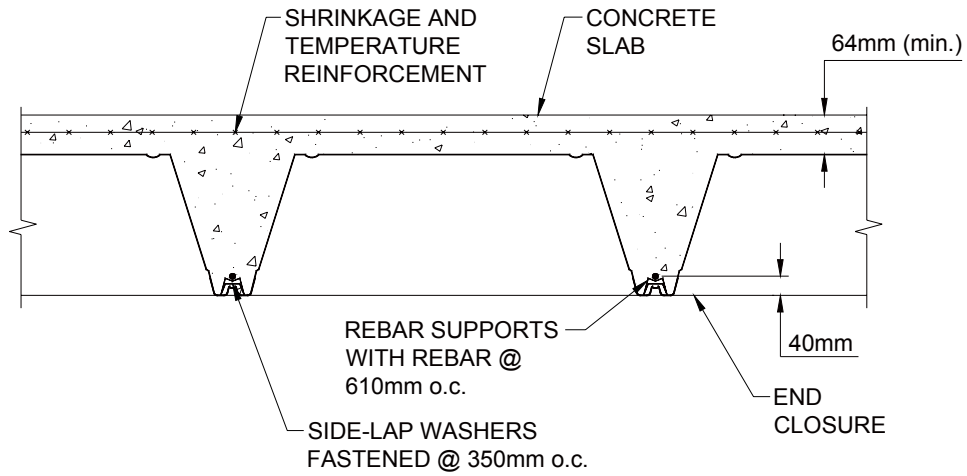

END CLOSURE DETAIL

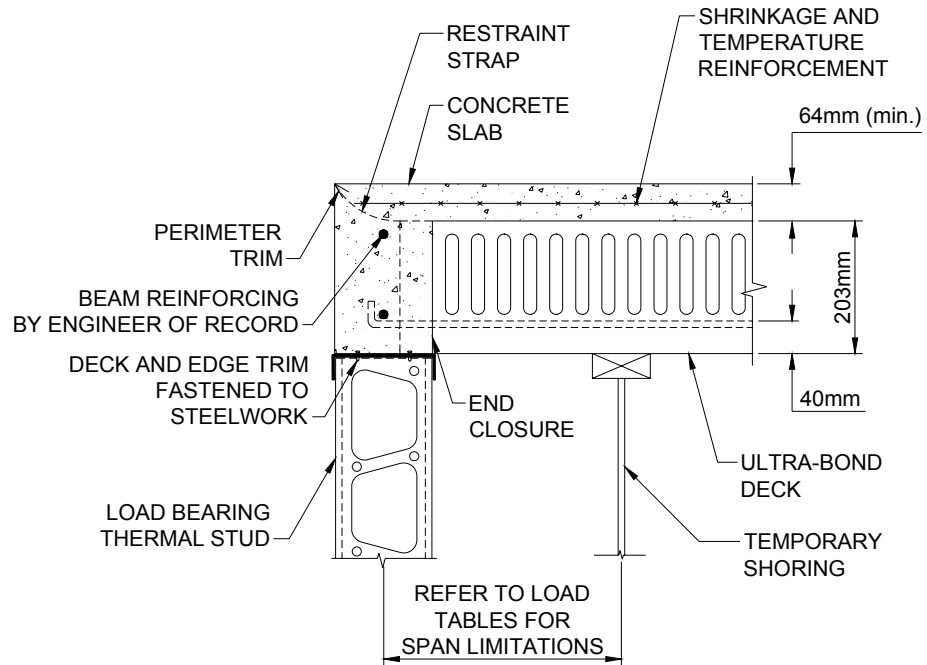

SHORING DETAIL

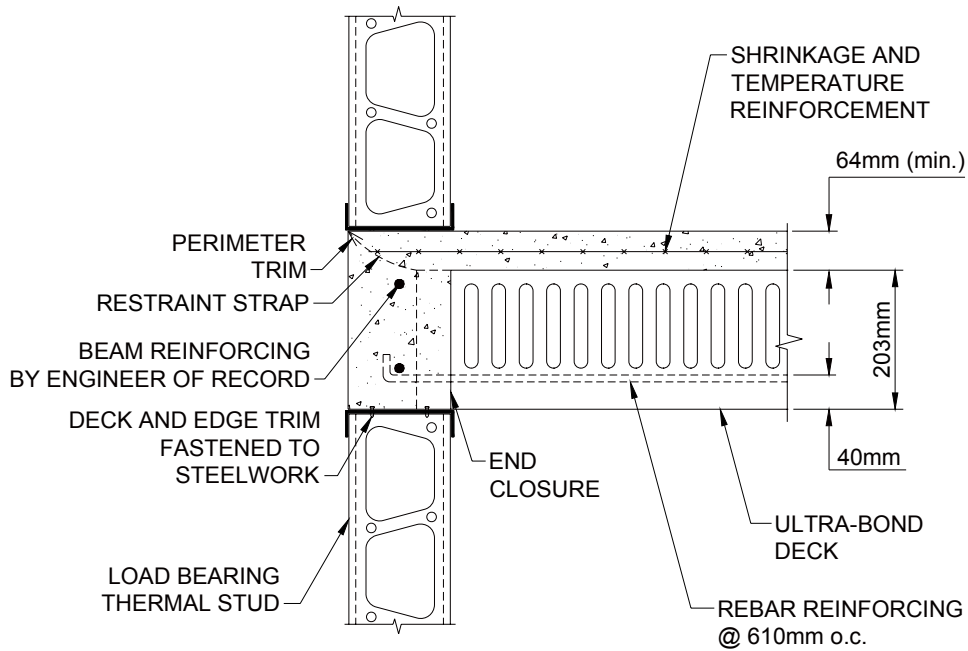

END BEARING DETAIL

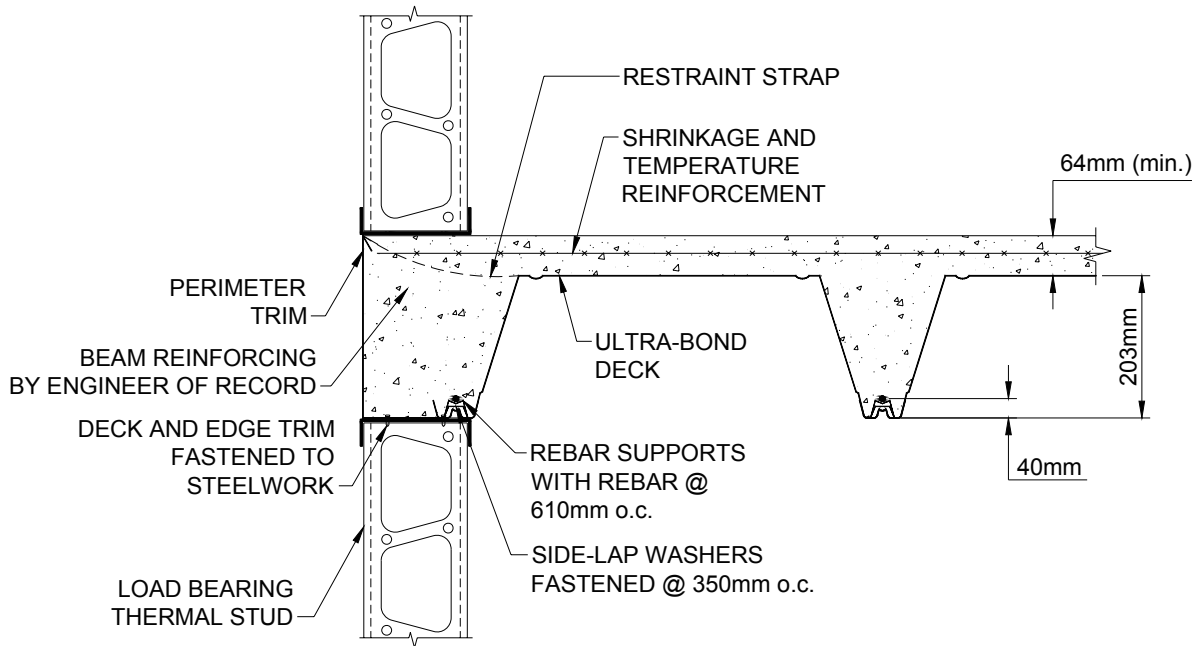

PERIMETER BEARING DETAIL

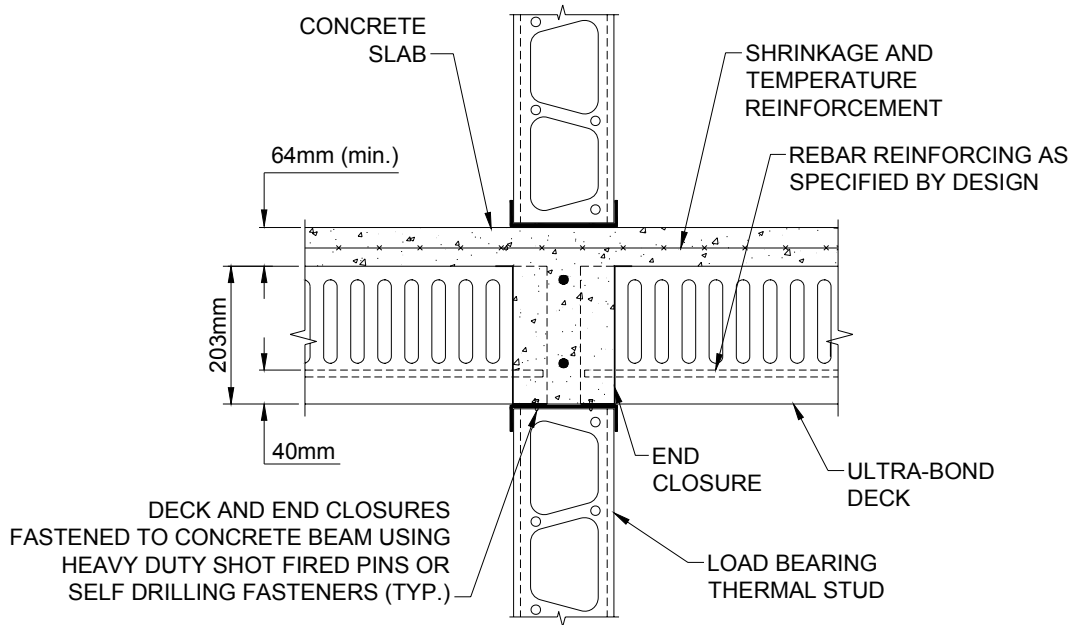

WALL CONNECTION DETAIL

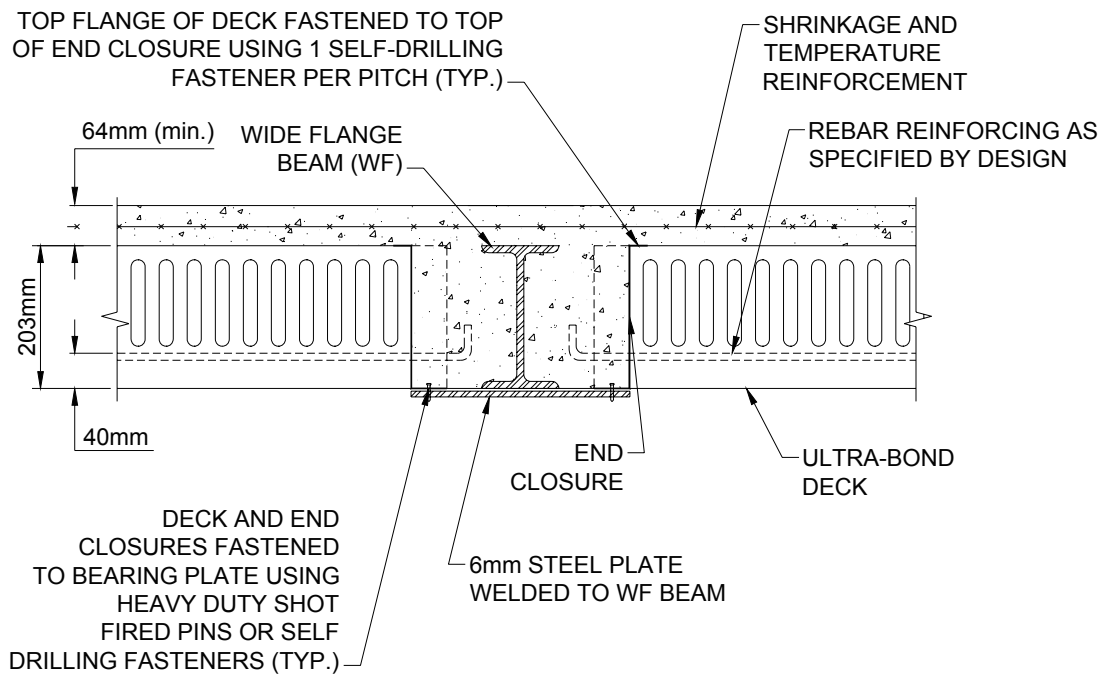

WIDE FLANGE BEAM DETAIL

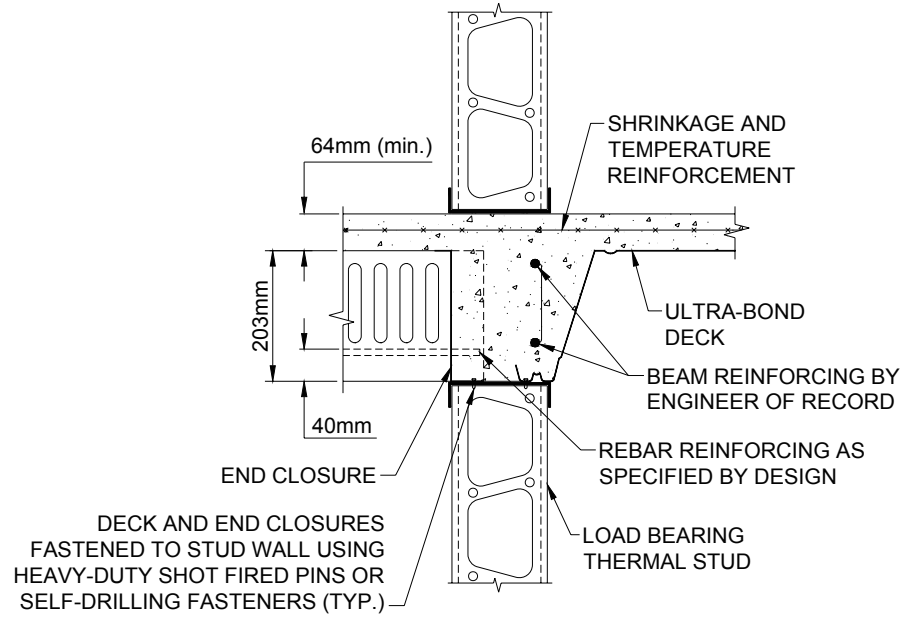

PANEL DIRECTION CHANGE DETAIL

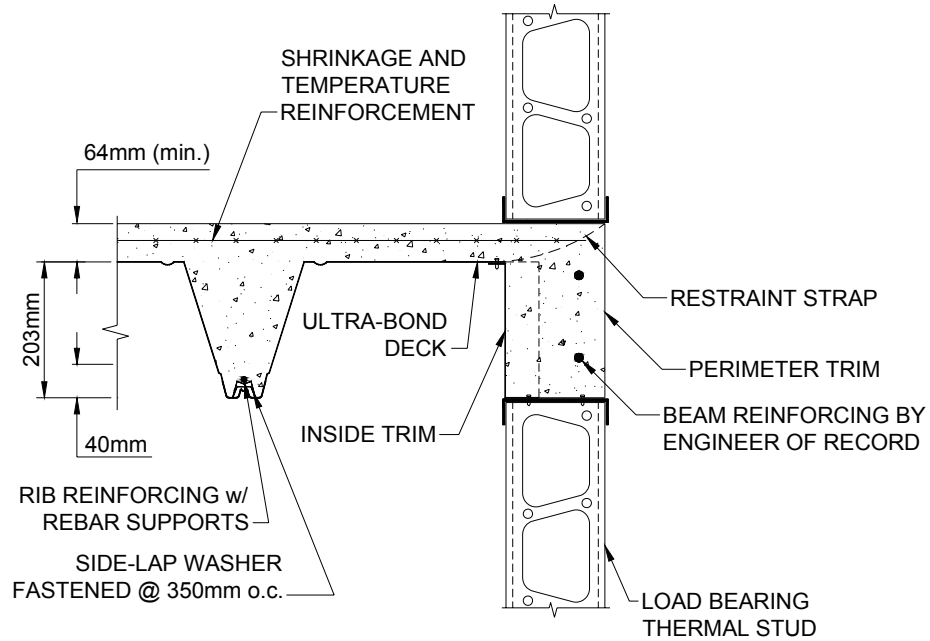

SIDE PERIMETER BEARING DETAIL

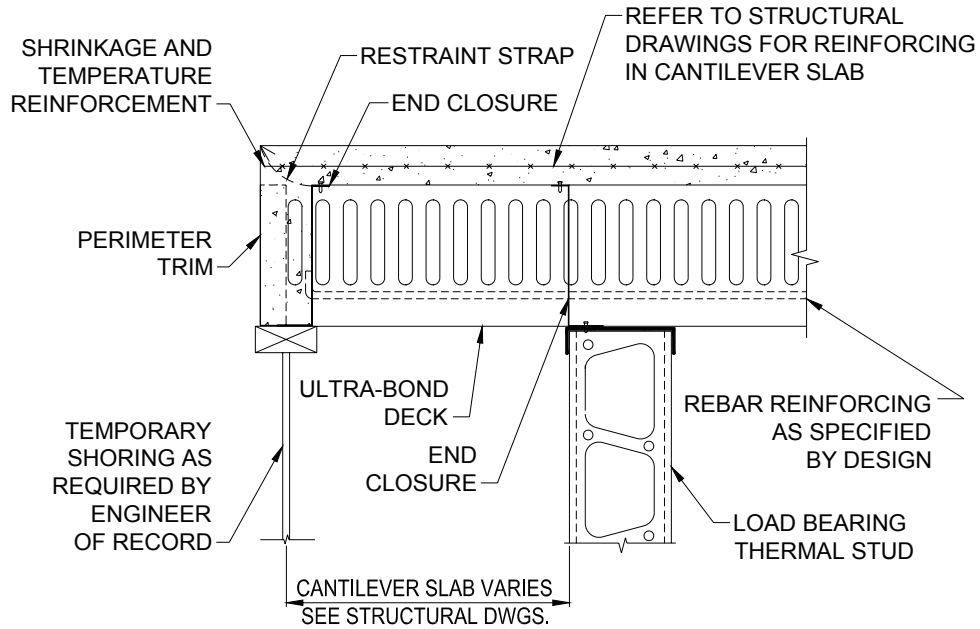

END CANTILEVER DETAIL

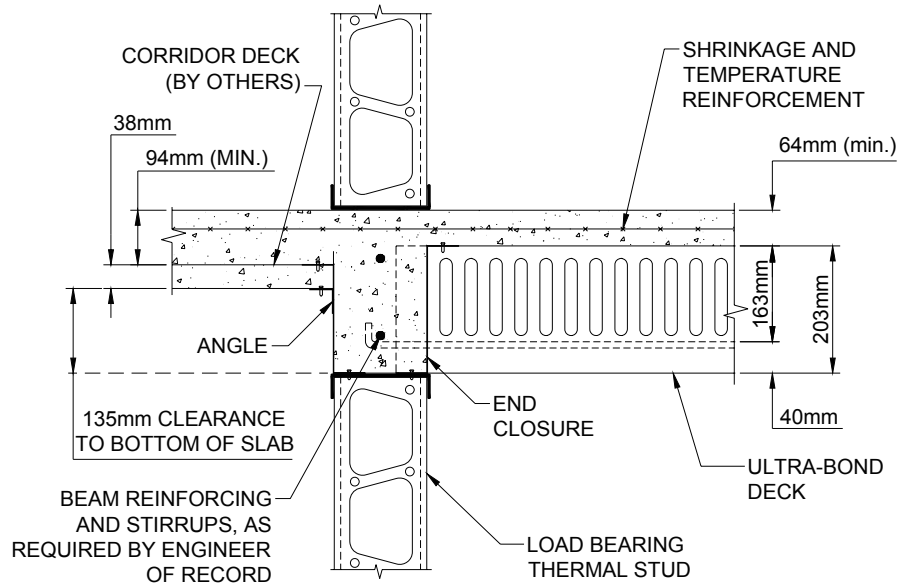

CORRIDOR BEARING DETAIL

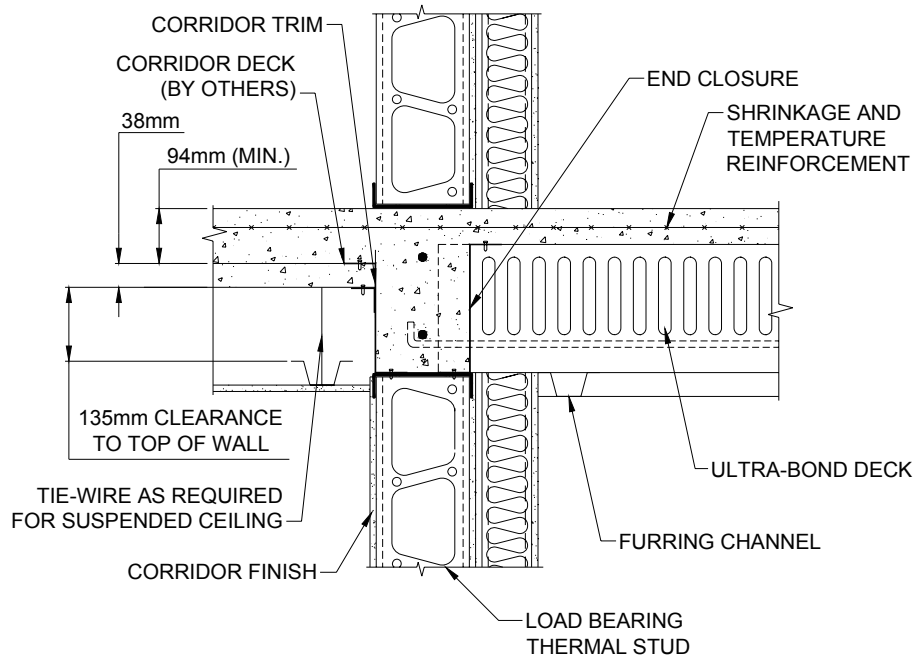

CORRIDOR FINISHING DETAIL

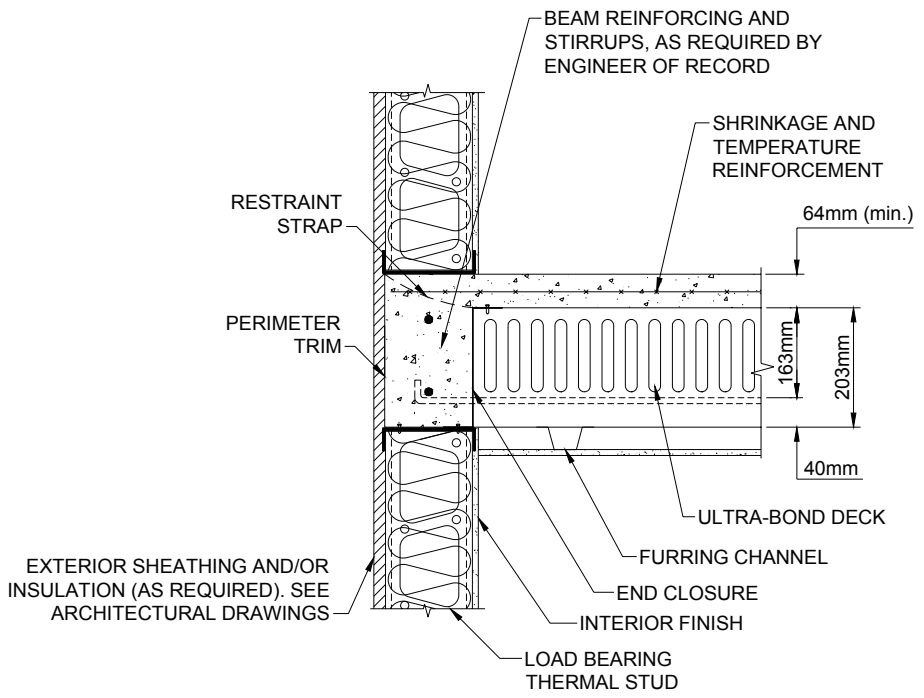

END BEARING FINISHING DETAIL

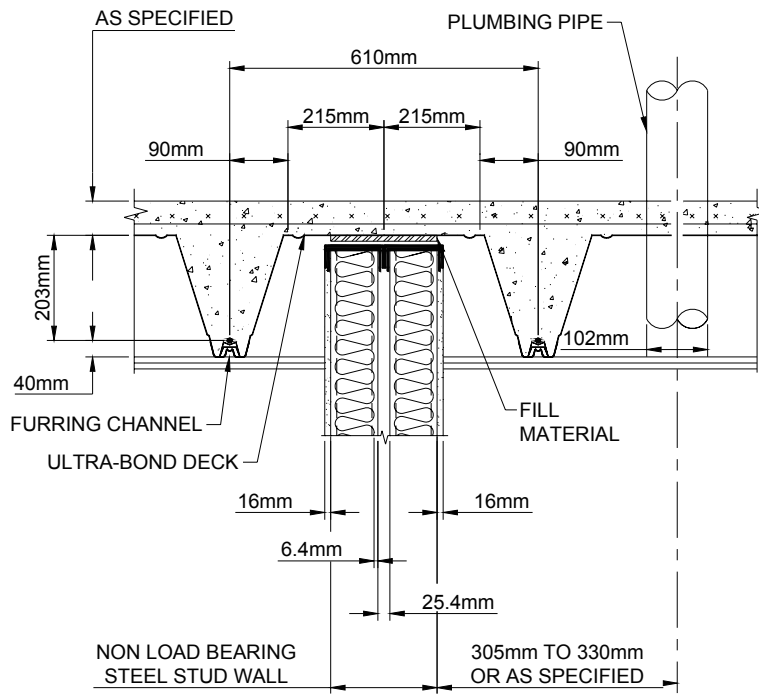
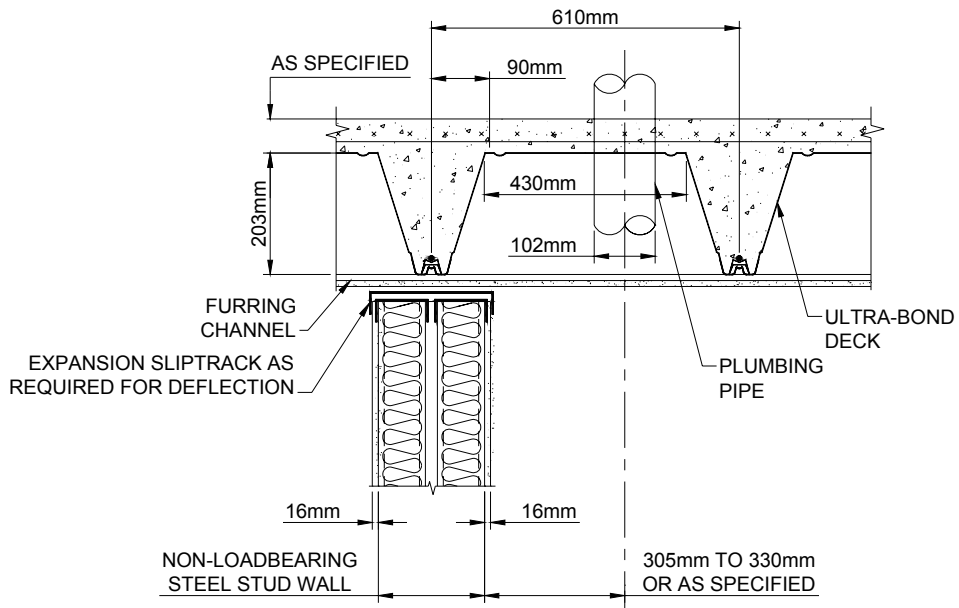

SUGGESTED CLEARANCE NEAR PLUMBING STACKS

**STEELFORM, ULTRA-BOND COMPOSITE
FLOOR DECK, DESIGN PROCEDURE
HOLE DIAMETERS ALLOWED**

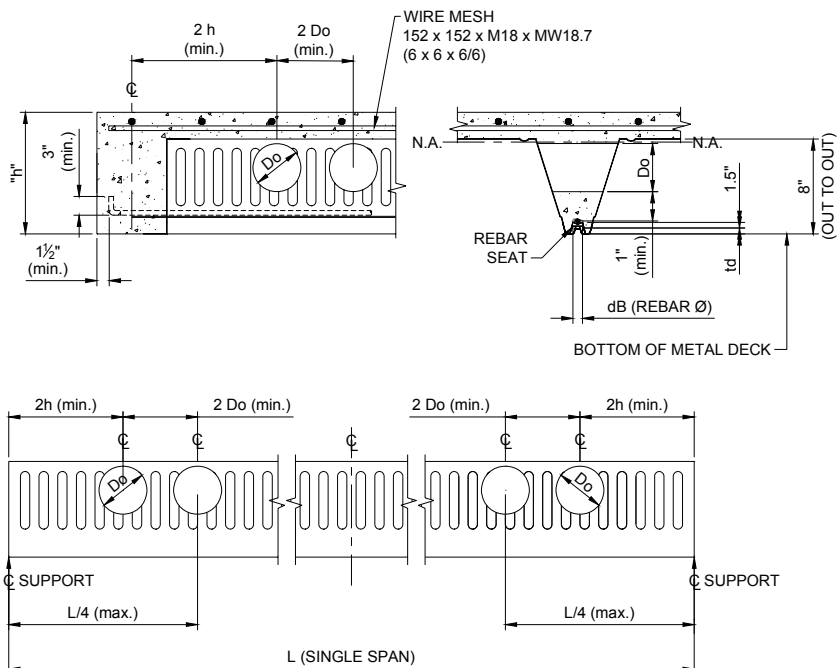

NOTATIONS:
h = OVERALL SLAB DEPTH
N.A. = NEUTRAL AXIS
Do = HOLE OPENING (MAX.)
dB = NOMINAL REBAR DIA.
td = METAL DECK THICKNESS

- NOTES:**
- (1) 25mm (1") OF CONCRETE COVER IS REQ'D ABOVE EACH REBAR (M IN.)
 - (2) THE CLEAR DISTANCE FROM BASE OF CONCRETE TO ϕ OF REBAR IS 1.5" (MIN.)
 - (3) NO MORE THAN TWO HOLES SHALL BE PLACED SIDE BY SIDE WITH THE END DISTANCE SPACING NOT LESS THAN 2h.
 - (4) THE SPACING BETWEEN ANY TWO HOLES SHALL NOT BE LESS THAN 2 Do.
 - (5) HOLES(S) SHALL BE POSITIONED AS SHOWN ABOVE (MAX L/4 FROM END SUPPORT).
 - (6) ONLY CIRCULAR HOLES ARE ACCEPTABLE AS SHOWN ABOVE.

TOTAL SLAB THICKNESS (H) (INCH)	REINFORCING STEEL BAR NOMIAL DIAMETER					HOLE DIAMETER IN (INCHES) (D)
	$d_B = 10\text{mm}$	$d_B = 15\text{mm}$	$d_B = 20\text{mm}$	$d_B = 25\text{mm}$	$d_B = 30\text{mm}$	
10.5	4.75	4.50	4.25	3.75	3.25	
11.0	5.25	4.75	4.50	4.00	3.75	
11.5	5.50	5.25	5.00	4.50	4.00	
12.0	6.00	5.75	5.25	5.00	4.50	
12.5	6.50	6.00	5.75	5.25	4.75	
13.0	6.75	6.50	6.25	5.75	5.25	
13.5	7.25	7.00	6.50	6.00	5.75	
14.0	7.75	7.25	7.00	6.50	6.00	

TOTAL SLAB THICKNESS (H) (mm)	REINFORCING STEEL BAR NOMIAL DIAMETER					HOLE DIAMETER IN (mm) (D)
	$d_B = 10\text{mm}$	$d_B = 15\text{mm}$	$d_B = 20\text{mm}$	$d_B = 25\text{mm}$	$d_B = 30\text{mm}$	
267	121	114	108	95	83	
279	133	121	114	102	95	
292	140	133	127	114	102	
305	152	146	133	127	114	
318	165	152	146	133	121	
330	171	165	159	146	133	
343	184	178	165	152	146	
356	197	184	178	165	152	

Construction Loads

In addition to the weight of the concrete and metal deck, at the time of concrete pouring, the following loads are normally allowed for:

- Uniform construction load of 1.0 kPa.
- Line load of 2.0 kN/m.

In order to keep construction loads to these limits, the following should be adhered to while placing the concrete:

- The concrete should be poured from a low level in order to avoid any impacting on the deck.
- The concrete should be placed uniformly over the supporting structure with minimal pile-up. It should be spread towards the center of the span.
- To minimize the possibility of the deck side-lap opening, sheet metal screws must be used to stitch side-laps.
- If buggies are used for concrete placement, adequate planking should be used as runways. Buggy movement should be restricted to these runways. The planks must be stiff and broad enough to distribute the load without damaging the deck.
- Shoring spacing must not exceed the unshored span shown in the Load Tables' Output Section #1.

Composite Loading

Design of the composite floor after curing of the concrete is similar to a one-way slab with positive reinforcement. The specified load on the slab is assumed to be uniform and static. In accordance with NBCC 1995, Clause 4.1.6.10, a concentrated load of 9 kN distributed over 750 mm is checked for. This load is taken as acting separately from the uniform loading. If there is heavy loading of a concentrated and/or dynamic nature, the deck should be used as a concrete form only. In some cases, it may be adequate to add extra reinforcement to the slab.

Strength design is based on combined loads due to steel deck, wet concrete and reinforcing bar. Construction loads are applied separately as follows:

- 1 kPa (21 psf) uniform load,
- 2 kN/m (137 lb./ft.) transverse line load at center of span.

Two unshored span load conditions are shown:

- 1 kPa (21 psf),
- 2 kPa (42 psf).

COMPUTER PROGRAM

To generate the Steelform's Ultra-Bond Load Tables and Graphs, a computer Program is included with the CD ROM Disc. One can vary any input data as one may encounter and obtain appropriate output data. The Computer Program is limited to the two deck thickness of 0.960 mm (0.0378") and 1.21 mm (0.0476") and the bar size of 10 mm to 30 mm in the increments shown in the Load Tables as well as the fixed metal deck configuration. This is due to the complex relation when the reinforcing bar reaches its yield point and the concrete at the beam top has not yet reached its full compression strength; at that stage, the steel deck contributes to the required additional tension. The amount of this contribution varies with the steel bar diameter, its distance from the concrete top, and the thickness of the metal deck, the total (A_{so}) is considered. Where (A_{so}) is the final effective cross-sectional area in inch square (steel bar and deck contribution).

Examples for the Proper use of Steelform Ultra-Bond Load Tables

EXAMPLE # 1

INTRODUCTION:

- 1) Although the strength equations used in generating the Load Tables are based on Limit State Design (LSD), with factor coefficients of $DL = 1.25$ for Dead Load and $LL = 1.50$ for Live Load, in accordance with the *National Building Code of Canada 1995*, the structural load tables provide a maximum "Specified" uniformly distributed load in (PSF) or (kPa), established in accordance with CSSBI 12M-84 and CSSBI S3-88.
- 2) The dead weight of the steel deck, reinforcing bar, wire mesh and concrete have already been accounted for in the Load Tables.
- 3) Accurate prediction of concrete creep protection is complicated because of the many variables such as:
 - Strength and composition of concrete
 - Concrete curing temperature and humidity
 - Composite member size (span length to beam depth ratio)
(See item 4 below)
 - Age at loading (minimum allowed 28 days after pouring of concrete)
 - Magnitude of stress (See item 4 below)

When composite floor members are shored during construction, creep deflection increase can become a critical consideration in design, when long term loading is present.

The following values of concrete creep deformation "multiplier factor" to compute long-time deflection based on Yu and Winter as well as "ACI" is presented in Table (1Z).

Table: 1Z

Duration of Loading	"Multiplier Factor"		
	A's = 0	A's = 1/2 As	A's = As
1 month	1.58	1.42	1.27
3 months	1.95	1.77	1.55
6 months	2.17	1.95	1.69
1 year	2.42	2.08	1.78
2 years	2.65	2.15	1.80
5 years	2.95	2.21	1.82
ACI-Code	3.00	2.40	1.80

As = Cross Sectional Area (in²) of bottom slab tension steel reinforcing.

A's = Cross Sectional Area (in²) of top slab compression steel reinforcing.

The final values of the "multiplier factor" to account for concrete creep deflection rests with the engineer in charge of the project design.

- 4) Based on finite element analysis and in spite of inclusion of shrinkage and temperature reinforcing bars in the concrete's top layer, the design professionals using Steelform's Ultra-Bond Load Tables **must multiply by a factor of (0.90)** the shown allowable single span in the Load Tables for the concrete thickness of 4.5" to 6.0" (including 4.5" and 6.0") above the top of the metal deck and for maximum specified uniformly distributed loads of 150 and 200 PSF only. (See design example #3).
- 5) The Computer Generated Load Tables account for deflection criteria of L/360 if deflection governs, by providing an appropriate span. Deflection criteria are based on the "Specified" uniformly distributed load. For design professionals wishing to determine actual allowable span for any load condition of: concrete cover, bar diameter and thickness of metal deck, Table (1X) and Examples are provided.
- 6) Load Tables are provided in Imperial and Metric Units, for metal deck thickness of 0.0378" and 0.0476", bar diameter of 10 mm to 30 mm in increments of 5 mm and concrete cover above top of metal deck of 2.50" to 6.0" in increments of 0.50", for the following "Specified" uniformly distributed loads: 40, 45, 50, 55, 60, 65, 70, 80, 85, 90, 100, 110, 120, 130, 140, 145, 150, 200, 250, 300, 350, 400, 450 and 500 PSF. Material specifications as shown on page 3 of this Manual.

DESIGN EXAMPLE # 1

GIVEN:

- Steel deck, core thickness, 0.0476", $FY=40.6 \text{ ksi}$
- Reinforcing steel bar diameter 15.0 mm (0.591"), $FY=58.0 \text{ ksi}$
- Concrete, normal density 150 P.C.F., $f_c = 4.35 \text{ ksi}$
- Slab depth above metal deck (h_c) = 2.50"
- Single span between supports = 20.0' (single shore required)
- Specified superimposed loads:

Partitions:	15.0 PSF
Floor Finish:	<u>9.0 PSF</u>
TOTAL:	24.0 PSF = (DL_s)

- (a) **DETERMINE:** Maximum allowable specified uniformly distributed load (PSF).

SOLUTION USING LOAD TABLES:

From Table Appendix A, Page 7	$h_c = 2.50''$ Span = 20.16' (Allowable)	$L_s = 150 \text{ PSF}$ (From Load Table) (Allow maximum specified uniformly distributed load)
-------------------------------	--	--

$$L_{s1} = L_s - \left(\frac{1.25}{1.50} \right) DL_s$$

Therefore: $L_{s1} = 150 - (0.833)(24.0) = 130.00 \text{ PSF}$

- (b) **CHECK DEFLECTION CRITERIA OF:** L/360 and L/480 (use Table 1X)

$$L_D = \left[\frac{(43703.7)(I_d)}{(Was)(K)} \right]^{0.333}$$

	$K = 1.0$ (L/360)	From Table 1X
	$K = 1.333$ (L/480)	[$I_d = 38.66 \text{ in}^4$]

$$(L/360) L_{D1} = \left[\frac{(43703.7)(38.66)}{(150)(1.00)} \right]^{0.333} = 22.35' \quad \text{Was} = 150 \text{ PSF}$$

$$(L/480) L_{D2} = \left[\frac{(43703.7)(38.66)}{(150)(1.333)} \right]^{0.333} = 20.30' > 20.16' \text{ therefore } \underline{\text{Strength Governs}}$$

COMPOSITE MOMENT OF INERTIA Table # Id (Table 1X)

Steel Deck Thick (in)	Reinf. Bar. Dia. (Inch) (mm)	CONCRETE SLAB COVER OVER TOP OF METAL DECK (in.) – AND EQUIVALENT Id (in ⁴) /FT							
		2.50"	3.00"	3.50"	4.00"	4.50"	5.00"	5.50"	6.00"
0.0378	0.394" 10 mm	33.12	37.83	42.93	48.47	54.58	61.21	68.47	76.43
0.0378	0.591" 15 mm	35.79	40.89	46.37	52.36	58.85	65.92	73.63	82.04
0.0378	0.787" 20 mm	38.22	43.57	49.43	55.79	62.68	70.19	78.34	87.20
0.0378	0.984" 25 mm	42.61	48.66	55.16	62.23	69.94	78.22	87.20	96.94
0.0378	1.181" 30 mm	46.50	53.18	60.38	68.15	76.50	85.61	95.35	105.92
0.0476	0.394" 10 mm	36.05	41.08	46.56	52.55	59.11	66.24	74.01	82.48
0.0476	0.591" 15 mm	38.66	44.01	49.87	56.24	63.18	70.76	78.98	87.90
0.0476	0.787" 20 mm	40.96	46.62	52.87	59.55	66.94	74.90	83.50	92.87
0.0476	0.984" 25 mm	45.16	51.53	58.40	65.86	73.89	82.61	92.10	102.29
0.0476	1.181" 30 mm	48.98	55.92	63.44	71.53	80.32	89.81	100.00	111.02

$$L_D = \left[\frac{(43703.7)(I_d)}{(W_{as})(K)} \right]^{0.333}$$

K = 1.0 for L/360 K = 1.67 for L/600

K = 1.333 for L/480 K = 2.0 for L/720

Id = Composite moment of inertia (in⁴) $I_d = \frac{I_c + I_u}{2}$ (in⁴) / ft

W_{as} = Maximum specified uniformly distributed load (PSF)

K = Deflection factor (see above)

Example: (a) W_{as} = 204 PSF (b) Bar 1.181" DIA. (c) Metal Deck 0.0378" thick
(d) Concrete cover 2.50" (e) Deflection L/360

FIND: Allowable span

$$L_D = \left[\frac{(43703.7)(46.50)^{(Id)}}{(204)(1.0)^{(Was)(K)}} \right]^{0.333} = 21.45'$$

DESIGN EXAMPLE # 2 :

GIVEN:

- Live Load = 40 PSF (LL)
- Superimposed Dead Load = 24.0 PSF (DL_s)
- Single span required = 30.0'

(a) **DETERMINE:** most economical composite floor combination.

SOLUTIONS USING LOAD TABLES:

$$L_S = LL + 0.833 DL_S$$

Therefore: $L_S = 40 + (0.833)(24) = 60$ PSF

From Appendix E, Page 4

- Steel Deck, Core Thickness, 0.0378", F_y = 40.6 Ksi
- Reinforcing bar diameter 0.984" (25 mm), F_y = 58.0 Ksi
- Concrete, normal density 150 PCF, f_c = 4.35 Ksi
- Slab depth above metal deck (h_c) = 2.50"
- **Allowable span (single) between supports = 30.18' > 30.0' therefore OK**

(b) **CHECK DEFLECTION CRITERIA OF:** L/360 and L/480 (use Table 1X)

$$L_D = \left[\frac{(43703.7)(Id)}{(Was)(K)} \right]^{0.333}$$

K = 1.0 (L/360) From Table 1X
K = 1.333 (L/480) [Id = 42.61 in⁴]
Was = 60 PSF

$$(L/360) L_{D1} = \left[\frac{(43703.7)(42.61)}{(60)(1.0)} \right]^{0.333} = 31.32' > 30.18' \text{ therefore } \underline{\text{Strength Governs}}$$

$$(L/480) L_{D2} = \left[\frac{(43703.7)(42.61)}{(60)(1.333)} \right]^{0.333} = 28.46' < 30.18' \text{ therefore not good}$$

Try h_c = 3.5" I_d = 55.16 in⁴ From Table 1X therefore

$$L_{D2} = \left[\frac{(43703.7)(55.16)}{(60)(1.333)} \right]^{0.333} = 31.0' > 30.0' \quad \text{therefore (OK)}$$

From Appendix E, Page 4 Allowable $L_S = 30.07'$ (strength governs)

Therefore for L/480 deflection criteria use same as above, but $h_c = 3.50''$

DESIGN EXAMPLE #3 – (Creep of Concrete Criteria)

Given:

- Live Load = 130 P.S.F. (LL)
- Superimposed Dead Load = 24.0 P.S.F. (DL_s)
- Single Span Required = 26.0'

(a) Determine Most Economical Composite Floor Combination

SOLUTIONS USING LOAD TABLES:

$$L_S = LL + 0.833 DL_S$$

Therefore: $L_S = 130 + (0.833)(24) = 150 \text{ P.S.F.}$

From Appendix A Page 9:

- Steel Deck, Core Thickness 0.0476", FY = 40.6 Ksi
- Reinforcing Bar Dia. = 0.984" (25mm), FY = 58.0 Ksi
- Concrete, Normal Density 150 PCF., $f_c = 4.35 \text{ Ksi}$
- Slab Depth Above Metal Deck $h_c = 6.0''$
- Allowable Span (Single) Between Supports = $(29.09)(0.9) = 26.18' > 26.0'$
therefore (OK)

See Item 3 and 4, page 14 and 15

(0.9) = concrete creep span reduction coefficient

(b) **CHECK DEFLECTION CRITERIA OF:** L/480 and L/600 and L/360

$$L_D = \left[\frac{(43703.7)(I_d)}{(W_{as})(K)} \right]^{0.333}$$

K = 1.333 For Defl. (L/480) K = 1.0 For Defl (L/360)
K = 1.67 For Defl. (L/600)

From Table (1X) $I_d = 102.29 \text{ in}^4$
 $W_{as} = 150 \text{ PSF}$

$$\text{For (L/480) } L_{D1} = \left[\frac{(43703.7)(102.29)}{(150)(1.333)} \right]^{0.333} = 28.08' > 26.0' \text{ therefore (OK)}$$

$$\text{For (L/600) } L_{D2} = \left[\frac{(43703.7)(102.29)}{(150)(1.67)} \right]^{0.333} = 26.05' > 26.0' \text{ therefore (OK)}$$

Final Conclusion: 26.0' Span OK for Strength or L/600 Deflection

$$\text{For (L/360) } L_{D3} = \left[\frac{(43703.7)(102.29)}{(150)(1.0)} \right]^{0.333} = 30.85' > 29.09' \text{ therefore (OK)}$$

The structural Load Tables and technical information contained in this catalogue were prepared by Michael Sommerstein, P. Eng. M&H Engineering and Wendy Zhu, Ph.D., P.Eng., Bodycote Material Testing Canada Inc. on 14-Feb-05.

Link

<http://www.steelform.ca/ultrabond.asp>

CONSTRUCTION GUIDELINES

Decking Installation

Ultra-Bond Floor Decking shall be positively fastened to the supporting structure to avoid movement during construction and excessive deflection during placement of concrete. The fastening frequency of main fasteners is 1 per trough at each panel end at 610 mm (24 inches) on centre along the support structure. When fastening panels to structural steel work, use heavy duty shot fired pins or self-drilling fasteners designed and specified by the engineer of record. For brick, block and concrete, the decking shall be fastened using adequate masonry fasteners as designed and specified by the engineer of record. In addition to the main fasteners, the top flanges of the end diaphragm closures shall be fastened to the decking, one fastener per module, either centered or 610 mm (24 inches) on centre. Side-lap washers shall be fastened at 350 mm (13.8 inches) centres along the bottom trough. The location of the fasteners is pre-punched on the male trough flange, which overlaps the female trough flange. Use self-drilling fasteners with a minimum 5.5 mm (0.217 inches) diameter.

Note # 1: Every side-lap fastener shall include a side-lap washer. This washer is required to properly attach the individual steel deck panels together.

Note # 2: When a suspended ceiling is used, the minimum thread length of the fastener is 25 mm (1 inch).

The bottom flange of the end closure shall be fastened to the supporting structure with 1 fastener per module at 610 mm (24 inches) on centre or as specified by the engineer of record.

Restraint Straps

The top of the perimeter trim is connected to the decking with restraint straps at approximately 400 mm (15.75 inches) on centre using either pop rivets or self-drilling fasteners. The restraint strap can be adjusted to suit the pitch and alignment of the perimeter trim.

Penetrations

Penetrations through the floor decking shall be cut after the concrete has cured. Before placing concrete, any openings shall be boxed out with form work as specified by the engineer of record. The following guidelines are suggested for isolated openings at right angles to the deck span, or as specified by the engineer of record.

- Up to 300 mm (12 inches) square penetrations centered on the top of the profile deck is acceptable without additional reinforcement, other than the minimum shrinkage and temperature mesh.
- Up to 425 mm (16.7 inches) width by 1,000 mm (39.4 inches) length opening, additional light gauge reinforcements are required.
- Openings larger than 425 mm (16.7 inches) require structural steel framing as specified by the engineer of record.
- Close grouping of openings transverse to the profile shall be treated as one opening, requiring additional reinforcement as specified by the engineer of record.
- After the slab has reached 75% of the required concrete compressive strength, a nibbler, power saw or coring machine can be used to cut openings in the top profile with the approval by the engineer of record.

Care shall be taken to avoid concrete heaping in any area during concrete placement. Typical construction live loads have been accounted for in the load tables. Should additional construction loading be required, approval by the engineer of record is required.

Temporary Supports

When the design span exceeds the maximum unshored span shown in the load tables, the wet concrete weight and construction loads shall be supported by adding temporary supports (shoring), as designed by the engineer of record. Where temporary supports are required it is important that:

- Beams and the support structure have adequate strength to support the construction loads as designed and specified by the engineer of record.
- Shoring is normally placed at mid span or at other suitable intervals as required.
- Shoring beams shall provide a minimum bearing width of 100 mm (4 inches).
- The shoring structure shall remain in place until the concrete has reached 75% of its design strength, or as specified by the engineer of record.

Hanger System

The magnitude and spacing of the suspended loads carried by the Steelform Ultra-Bond Composite System must be evaluated by the engineer of record to ensure that the composite system can carry it safely. This includes proper connections.

End Closures

To minimize grout loss at the profile ends during concrete placement, end closures are provided to contain the concrete. These closures are manufactured from 54 mil galvanized steel, generally 1830 mm (6 feet) long or longer for angle cut installations. End closures shall be fastened to the support structure with a minimum of 2 fasteners (such as shot-fired pins or self-drilling fasteners), or as specified by the engineer of record. Apart from minimizing grout loss during concrete placement, these end closures provide strength to assist prevention of web crippling of the steel deck and proper alignment of the decking during construction. When used in conjunction with hot rolled steel beams, these end closures provide concrete cover to the beam for fire resistance.

Side-lap Washers

Since the Ultra-Bond Floor Deck acts in part compositely with concrete, side-lap washers are important connecting elements. These washers are pre-punched to receive the self-drilling fastener.

Cantilevers

Ultra-Bond Floor Deck can be end cantilevered. When side cantilevers are required, stub beams or brackets shall be provided by the structural steel fabricator, as designed by the engineer of record. Cantilevers shall also be assessed for positive and negative reinforcement by the engineer of record.

Perimeter Edge Trims

Are required for the retention of wet concrete to the correct level at the decked floor perimeters and designed openings. They are supplied in 3 m (10 feet) lengths of galvanized steel. The trims are usually fastened by shot-fired pins to the structural steel or by self-drilling fasteners to the support structure at 610 mm (24 inches) on centre, or as specified by the engineer of record.

Columns and Ultra-Bond Floor Decking

The steel deck sheeting can be cut and fitted to accommodate various column shapes to minimize grout loss. Where no supporting steel work is provided, steel angle brackets shall be provided to support the steel decking, as specified by the engineer of record.

Rib Reinforcement and Mesh Placement

The Ultra-Bond Floor Deck design requires that one steel reinforcing bar be placed in each rib profile. The bar size, as shown in the load tables, can vary from 10 mm (0.394 inches) to 30 mm (1.18 inches) in diameter. The bars shall be placed on bar supports 40 mm (1.57 inches) above the rib profile bottom flange. This ensures 40 mm (1.57 inches) spacing from the bottom flange to the underside of the reinforcing bars.

Spacing of the reinforcing bar supports shall be in accordance with good practice guidelines, and not exceeding 1220 mm (48 inches) on centre. To ensure both vertical and horizontal stability during concrete placement, the reinforcing bars shall be tied down periodically through side-lap washers with 1.21 mm (0.0476 inches) diameter tie wiring. It is recommended that a minimum standard shrinkage and temperature reinforcing mesh of 152 x 152 x MW18.7 x MW18.7 (6 x 6 x 6/6) be placed above the top of the steel decking and positioned towards the top of the slab, or as specified by the engineer of record.

Concrete Placement

Concrete shall be placed in accordance with CAN/CSA A23.1-94. Before starting concrete placement, the steel decking shall be cleared of dirt, grease and debris, which could adversely influence the composite slab performance.

Service Holes

Refer to table on page 12 for size and location of round holes through Ultra-Bond Floor Deck ribs. Sleeves shall be fastened in place before concrete placement. Cut-out of



holes shall be done only after the concrete has reached 75% of its design strength, or as specified by the engineer of record.

Ceiling Hanger System

Ceilings can be suspended directly from the self-drilling side-lap fasteners in the decking troughs, which at 610 mm (24 inches) centres, are ideally lined up for standard ceiling tile grids (consult with the engineer of record for hardware approval).

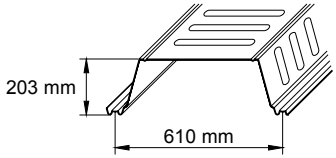
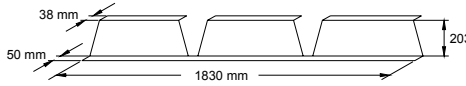
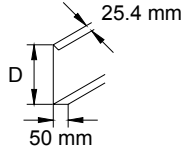
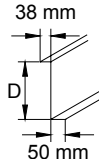
Trims and Accessories

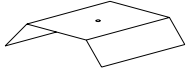
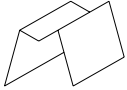
MATERIALS	THICKNESS		WEIGHT		PACKAGING
	mm	inches	SI-Metric	Imperial	Pieces
ULTRA-BOND FLOOR DECK 	0.96	0.0378	0.124 KpA	2.59 PSF	20 pcs/bundle or as per request – cut to length.
	1.21	0.0476	0.155 KpA	3.24 PSF	
END CLOSURES 	1.52	0.0600	2.98 kg/m	2 lb/ft	50 pcs/bundle
	1.52	0.0600	5.44 kg/pc	12 lb/pc	Custom angles available upon request.
PERIMETER TRIMS 	1.52	0.0600	17.7 kg/pc	39 lb/pc	10 pcs/bundle
			20.4 kg/pc	45 lb/pc	10 foot lengths
INSIDE TRIMS 	1.52	0.0600	13.6 kg/pc	30 lb/pc	10 pcs/bundle
	1.22	0.048	11.3 kg/pc	25 lb/pc	
	0.914	0.036	9.1 kg/pc	20 lb/pc	10 foot lengths

<p>SIDE LAP WASHERS</p> 	1.22	0.048	11.3 kg/pc	25 lb/pc	500 pcs/ctn
<p>REBAR SUPPORTS</p> 	0.914	0.036	20.4 kg/pc	45 lb/pc	300 pcs/ctn
<p>RESTRAINT STRAPS</p> 	0.914	0.036	9.1 kg/pc	20 lb/pc	100 pcs/ctn
<p>FASTENERS</p> <p>#12 x 1" Hex Self-Drilling Zinc.</p>			20.4 kg/pc	45 lb/pc	3000 pcs/ctn



4101 – 69 AVE
Edmonton, Alberta T6B-2V2
Phone: (780) 440-4499
Toll Free: 1-866-440-4499
Fax: (780) 465-4910

Steelform Building Systems Inc
60 Enterprise Road
Toronto, Ontario M9W-1C9
Phone: (416) 245-7006
Toll Free: 1-877-245-7073
Fax: (416) 245-7698

Book Design and Illustration by Shane Lynch and TheCGN Designs
www.thecgn.com